

TEXTURE INVESTIGATIONS ON HIGH TEMPERATURE SUPERCONDUCTORS

DIETRICH SCHLÄFER, KLAUS FISCHER, MARGITTA SCHUBERT
and BRIGITTE SCHLOBACH

Institut für Festkörper- und Werkstoffforschung e. V. Dresden

(Received 10 September 1994; in final form 7 November 1994)

The formation of a structure with strong crystallographic texture is an important requirement for high critical current densities at 77 K in high temperature superconductive materials (HTSC). In this work several methods for texture investigation in the superconductive phase of BiPbSrCaCuO/Ag- and YBaCuO/AgPd-composite conductors prepared according to the "powder in tube"-method as well as in YBaCuO-thick layers are presented. For the characterisation of the texture development in dependence on technological steps at the preparation of HTSC-composite conductors the determination of the half-width FWHM from the psi-scan or for one-phase specimens the determination of the Lotgering-factor is appropriate, if only a c-axis exists. The measurement of pole figures is necessary to determine, whether a rotation symmetry occurs or an orientation of the (a,b)-directions exists. The use of the omega-scan to determine the half-width is not useful, if the goniometer unit is intended and optimised for phase analysis and therefore the secondary monochromator cannot be relinquished.

KEY WORDS: HTSC, texture, pole figures.

INTRODUCTION

The critical current density j_c of $\text{YBa}_2\text{Cu}_3\text{O}_x$ - and $(\text{Bi,Pb})_2\text{Sr}_2\text{Ca}_2\text{Cu}_3\text{O}_{10}$ - high temperature superconductors is highly dependent on the crystallographic plane in the current flows. The superconductors examined here have an orthorhombic crystal structure. The lattice parameters for the YBaCuO-phase and the BiPbSrCaCuO-phase are $a = 3.82 \text{ \AA}$, $b = 3.89 \text{ \AA}$, $c = 11.68 \text{ \AA}$ and $a = 5.41 \text{ \AA}$, $b = 5.41 \text{ \AA}$, $c = 37.13 \text{ \AA}$, respectively. Due to the strong crystalline anisotropy of the HTSC-phases the critical current density in the (a,b)-plane is much higher than in perpendicular direction. Thus for the texture development the aim is to orient the c-axes of the crystals perpendicular to the current flow (c-axis texture).

After a good c-axis texture is obtained further improvement can be reached by an orientation of the (a,b)-axes (biaxial texture). This leads to a decrease of the large-angle grain boundaries and the great number of the weak links in these boundaries.

Often HTSC-crystals are platelets in which the (a,b)-plane is substantially greater than the vertical direction. Analysing a cross-section of the specimen the orientation of these crystals and the possible inhomogeneity can both be easily determined. The c-axis texture of the crystals can also be identified using intensity change of single reflections in an X-ray diffraction diagram in comparison with a random power diagram (Malik, 1988; Sekine, 1989). The quantitative intensity change is expressed by the Lotgering-factor (Lotgering, 1959; Moore, 1988). The texture development during heat

treatment was observed by means of the Lotgering-factor using high temperature diffractometry (Chen, 1992).

A measure of the c-axis texture scattering is determined by the omega-scan (Okado, 1988; Iijima, 1991; Grasso, 1994) by which the detector is adjusted permanently on a (001)-reflex, whereas the specimen is turned in the goniometer plane. Omega indicates the angle between the incident beam and the specimen plane. The curves obtained in this way sometimes are called rocking curves and the full width of the half maximum (FWHM) or in the case of a normal distribution the scattering width is given as a measure of the texture sharpness. Using neutron scattering such measurements could be performed with Ag-covered YBaCuO-samples without removing the silver-coating (Okado, 1988).

A more comprehensive description of the texture is achieved by pole figures (Knorr, 1989; Osamura, 1989; Moeckly, 1990; Aksenova, 1992; Itskovich, 1994). If in addition to a (001)-pole figure also a pole figure of a pyramid plane is determined it can be decided whether the (a,b)-axes are parallel. Because of the problems emerging by the low crystal symmetry and the problems caused by the pole figure overlapping the complete orientation distribution function is not often calculated (Gleitsmann, 1990; Liu, 1990; Kallend, 1991).

The influence of monocrystalline substrates on the growth of thin HTSC-layers is investigated frequently by the omega-scan of the (103)-reflex (Laderman, 1991; Chew, 1992; Chateigner, 1993) or by electron diffraction (Hwang, 1990). For the measurement of pole figures a primary monochromator is required, because otherwise considerable faults by Laue-reflections can occur.

SAMPLE PREPARATION

In this work the texture of the superconductive phase of BiPbSrCaCuO/Ag- and YBaCuO/AgPd-composite conductors is investigated. The specimens were prepared according to the "powder in tube"-method (Neumüller, 1994). In this process the precursor powder was filled in a silver-tubes. The composites were swaged and drawn to a monocoire wire. The monocoire wires were also inserted into a silver-tube. The multifilament-conductors were fabricated by hydrostatic extrusion, drawing and rolling of this composites to an overall thickness of ≈ 0.3 mm and width of ≈ 5 mm (Figure 1). The silver- or silver/palladium coating cannot be penetrated by the used cobalt $K\alpha$ -radiation. For X-ray measurement the samples are cut into 10 mm long pieces, the side metal rims are removed and the samples are cut in a way that the superconducting core is discovered. Several sample strips are joined together to form an area of about 1 cm². As a result of the preparation a rough surface is obtained. The grain size is about 10 μ m.

X-RAY MEASUREMENT

Lotgering-factor

The use of a quality factor f for the description of the texture of a film was suggested by Lotgering (1959). The factor varies from 0 to 1, according to changes in the film from complete irregularity to ideal orientation. The texture factor is defined by

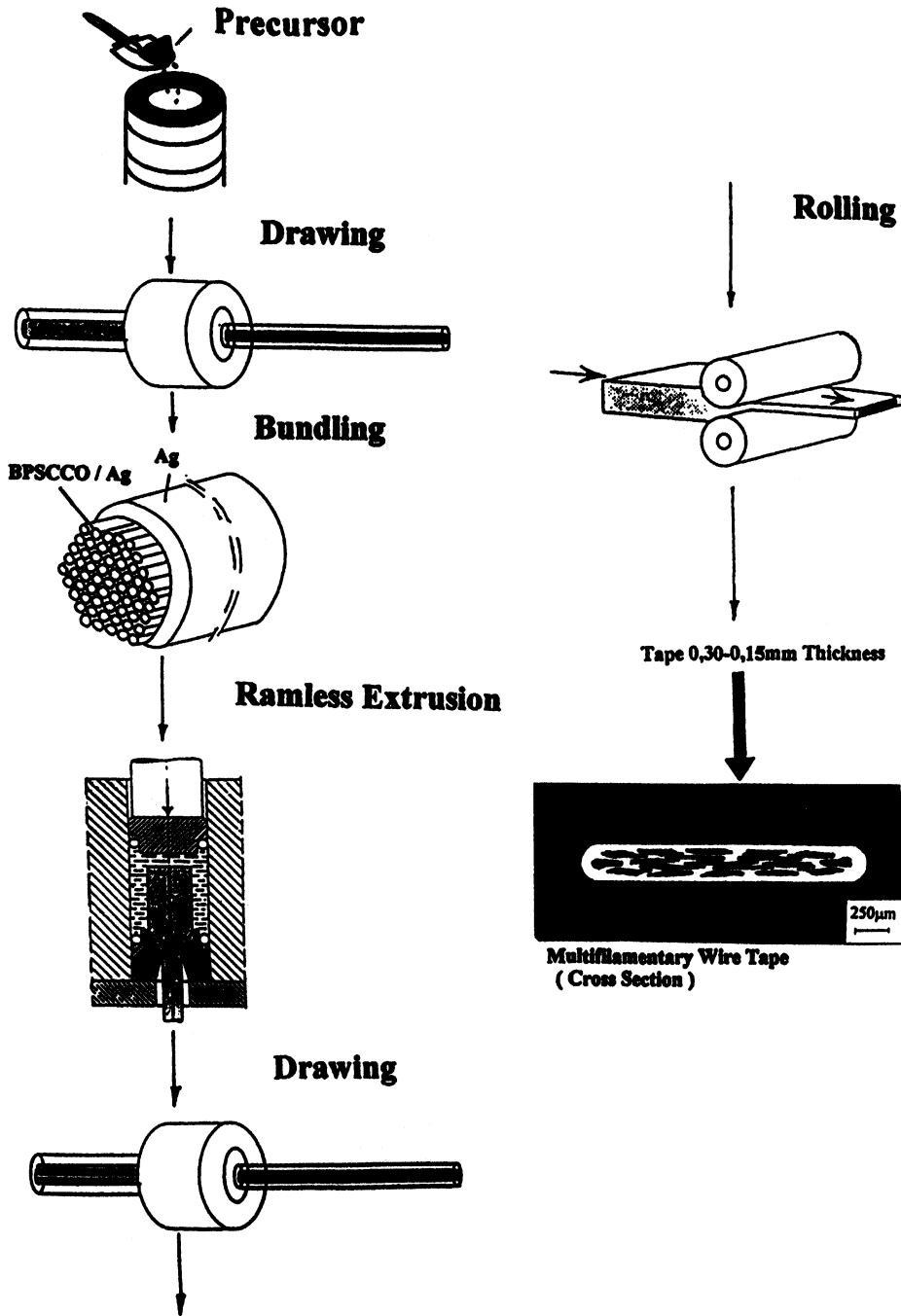

Figure 1 Scheme of the "powder in tube" technology.

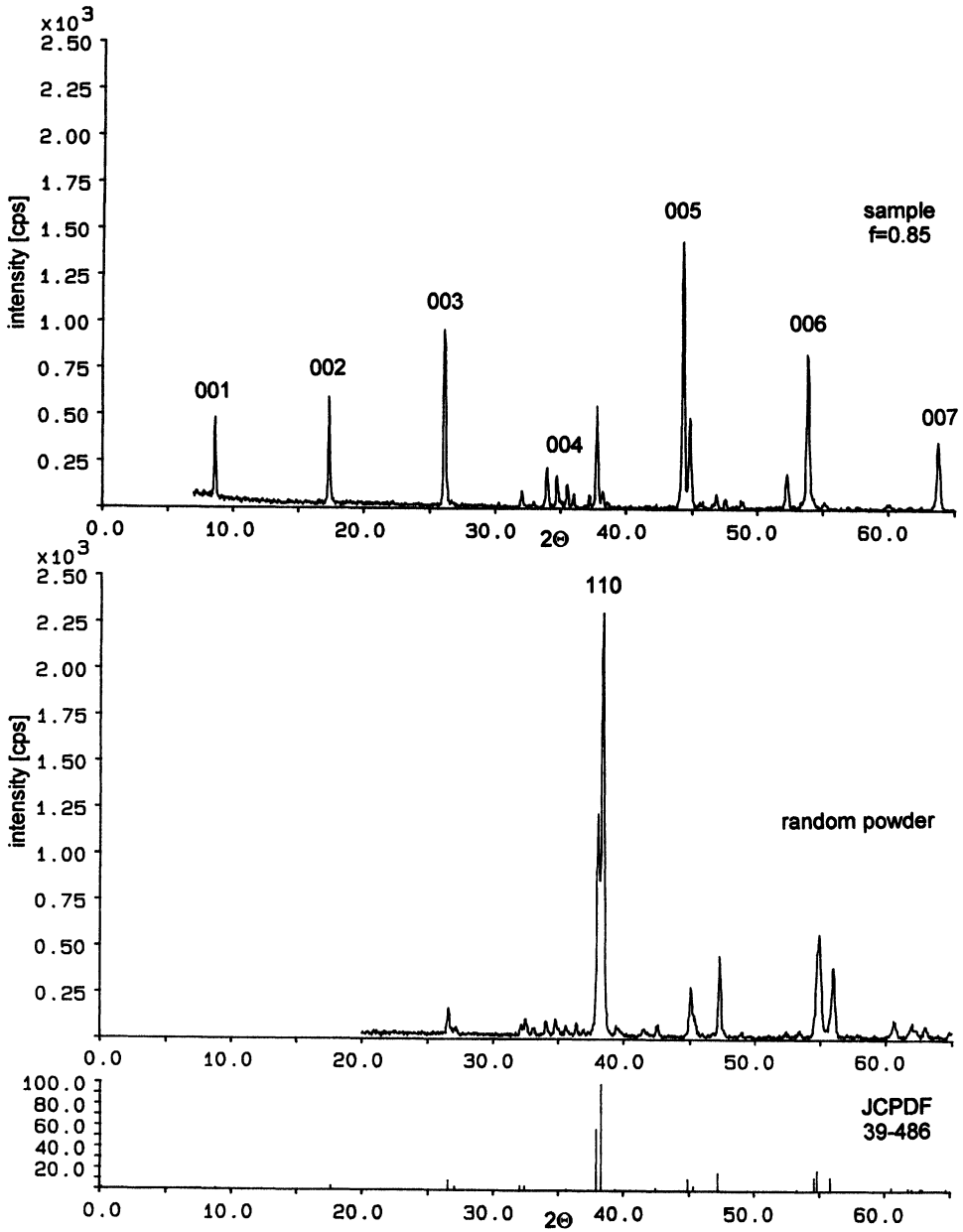

Figure 2 X-ray diffraction pattern for a YBaCuO – specimen with Lotgering-factor $f = 0.85$ and for a powder specimen as well as the JCPDF date, respectively.

$f = (p - p_0)/(1 - p_0)$, where p is equal to the intensity ratio of the reflection in the sample to be described to all reflections and p_0 is equal to the same ratio for a non-textured standard specimen. For those HTSC-samples in which c -axis texture is the intensities of all reflections have to be determined by a theta-2theta goniometer at the sample plane being parallel to the current flow. The reflections to be described are in this case the (001)-reflexes. In Figure 2 the results are shown for a textured YBaCuO-sample in comparison with a random powder sample and the JCPDF date. In both samples additional reflections of an unidentified phase are observed, in the textured sample also reflections of the silver-coating are found. In the textured sample the (001)-reflections are very intensified and the strongest powder (110) is essentially diminished.

Omega-scan

The use of omega-scan for the description of the c -axis texture scattering is complicated by the fact that the intensity will change in dependence on the angle omega even if there is no texture (Field, 1949). This change is caused by the following:

1. The focusing of the diffractometer is change.
2. The irradiated area is change.
3. The relative path of the incident and the reflecting beam is varied.

Therefore an intensity correction

$$I/I_0 = 2/(1 + \sin \omega/\sin (2\Theta - \omega))$$

is necessary, where I_0 is the intensity for symmetrical Bragg-diffraction. In order to verify the equation a random silicon powder specimen was investigated. Cu-K α radiation was employed and the detector was set at $2\Theta = 28.5$ degree, corresponding to the (111) plane. The slit in front of the detector was adjusted to 1.5 degree. The results are show in Figure 3, where I/I_0 or the measured intensity respectively are plotted against ω .

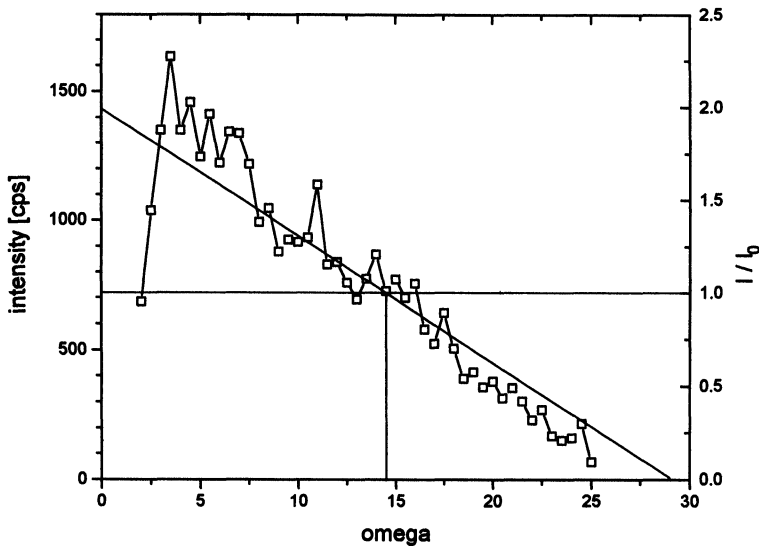

Figure 3 Comparison between measured values and correcting factor v.s. angle omega of the (111)-reflection of a random silicon powder.

In the region of higher ω -values a close correspondence was found between the intensity ratio based on the equation and the experimental results. At low incident angles great deviations between the calculated and the measured intensity are observed, because the incident X-ray beam appears greater than the sample surface.

Figure 4 shows an omega-scan obtained by a conventional goniometer for phase analysis. A Soller-collimator and a secondary monochromator were used. The reflected

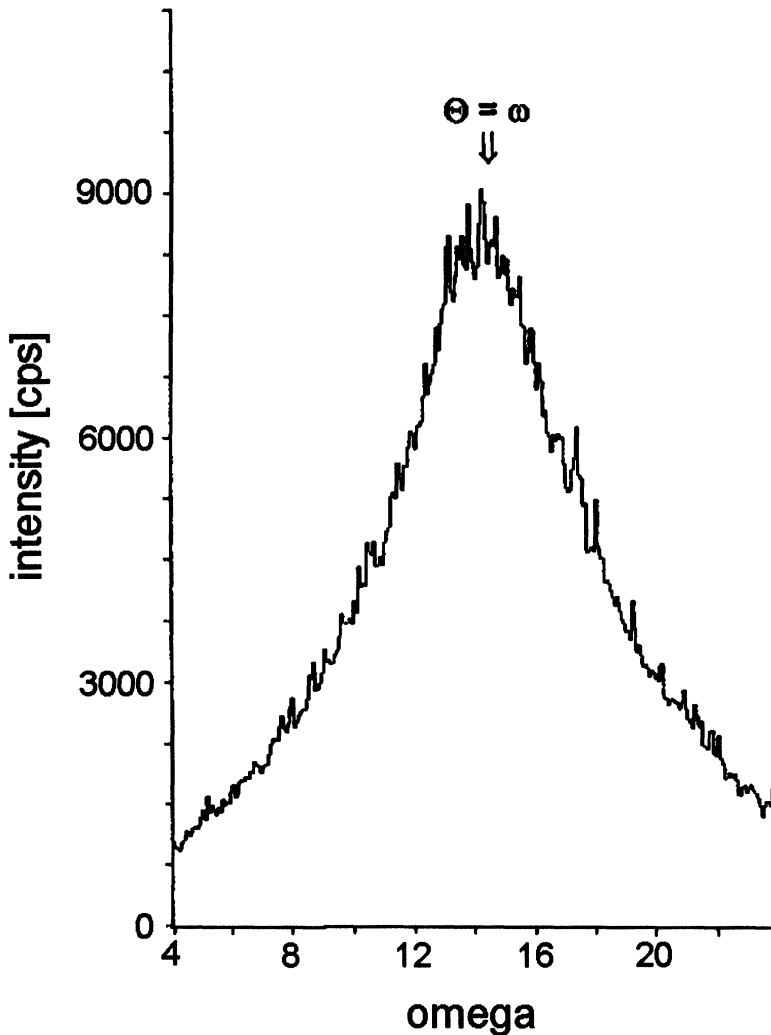

Figure 4 Rocking curve (omega scan) of the (111)-reflection of a random silicon powder. Measurement was carried out with a goniometer for phase analysis with Soller-collimator and secondary monochromator. The symmetrical position is at $\omega=14.3$ degree.

beam is narrowed to 0.15 degree. This omega scan of the (111)-reflection of the same random silicon powder as in Figure 3 shows that there is no correspondence between the experimental results and the nearly linear intensity ratio based on the equation. The Bragg-Brentano-relation is not fulfilled and only a part of the reflected beam passes the narrow slits of the monochromator. Therefore the use of the omega-scan for texture investigations with a conventional Bragg-Brentano-goniometer is controversial.

Pole Figures

It can be clearly shown by pole figures, how much for instance the c-axis texture has developed and whether an orientation of the (a,b)-directions was obtained. Figure 5a shows the (00.14)-pole figure of the BiPbSrCaCuO-phase of a composite conductor with distinct c-axis texture and Figure 5b demonstrates the (119)-pole figure of the same sample. The rotation symmetrical pole figures point to the fact that the rolling direction of the wire-like sample is no preferred crystallographic direction and that only a c-axis texture exists, i.e. the crystallographic (a,b)-axes are not parallel together. In this case the (119)-pole figures should have four maxima spaced equidistantly of 90 degree.

In the figures 6a and 6b the same pole figures are presented in 3 dimensions to improve clearness.

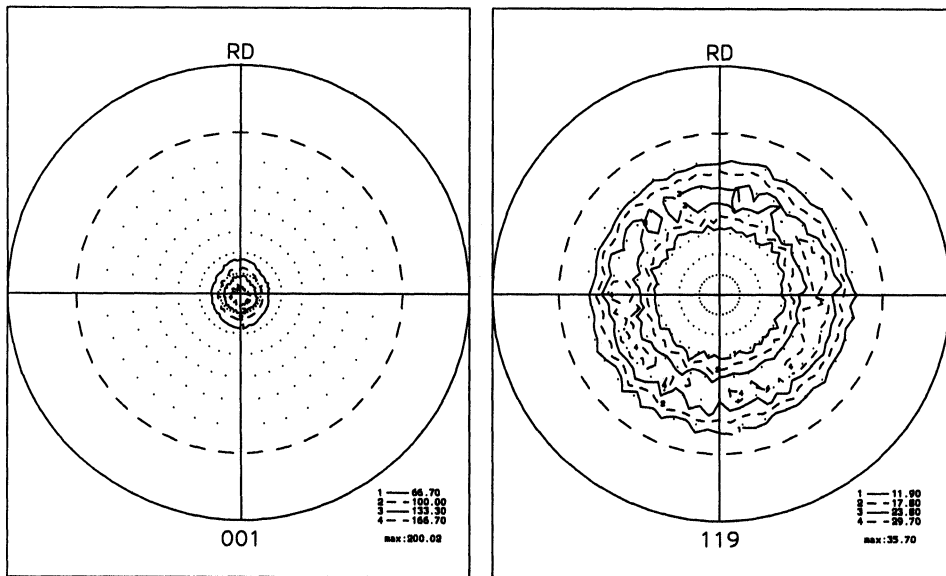
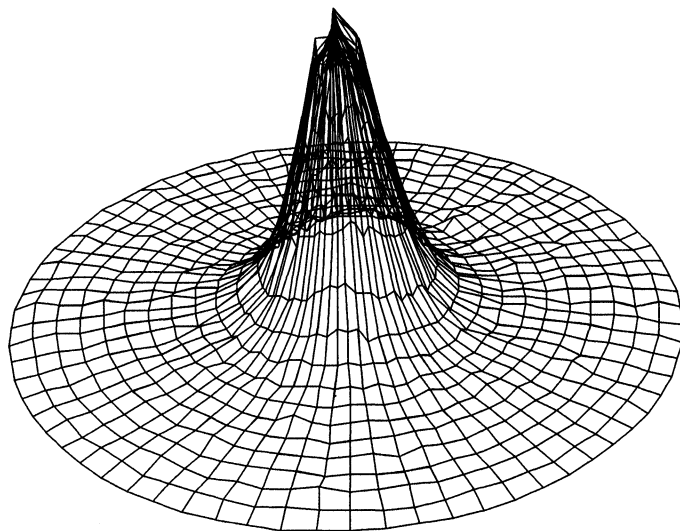
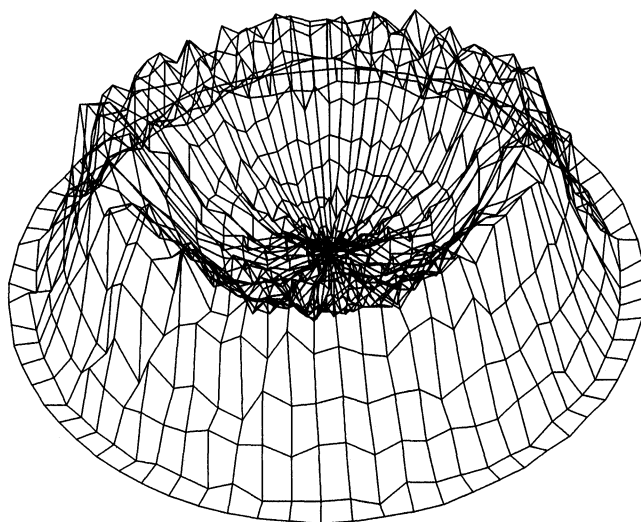

Figure 5 Pole figures for BiPbSrCaCuO “powder in tube” – tapes. The centre of the pole figures is the normal direction.



001

Figure 6(a) Perspective plots of the pole figures of figure 5 – (001).



119

Figure 6(b) Perspective plots of the pole figures of figure 5 – (119).

Psi-scan

If it was determined that the pole figures are rotationally symmetrical, it is sufficient for the characterisation of the texture to measure a section of the pole figures. In this case a psi-scan suits best, because the measured intensities are highly independent of the angle psi (Schulz, 1949). Psi is the angle between the specimen normal and the equatorial plane of the goniometer. In Figure 7 a section of the (00.14)-pole figure of a BiPbSrCaCuO-HTSC specimen is shown. As a measure of the texture the full width of the half maximum (FWHM) is taken.

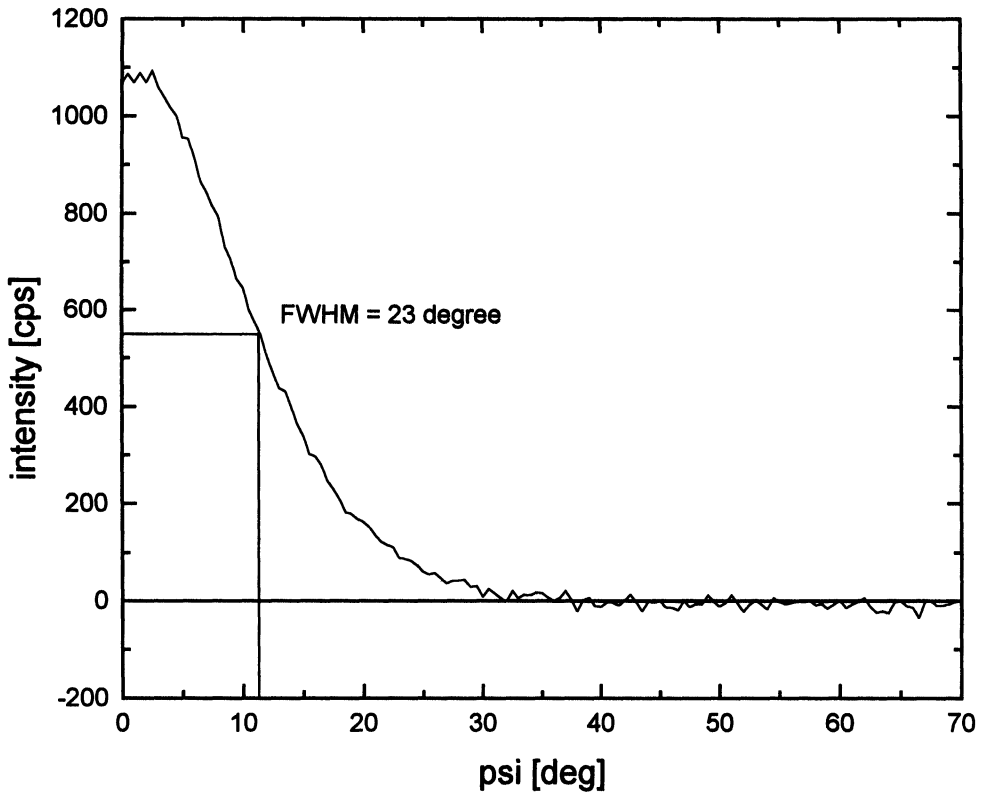

Figure 7 Cut through the (00.14)-pole figure (psi-scan) of the BiPbSrCaCuO- "powder in tube" – tapes.
FWHM = full width in half maximum.

DISCUSSION AND CONCLUSIONS

In Figure 8 the width of the c-axis texture FWHM is given as a function of the critical current density j_c . All samples were prepared by the same technological treatment. No relation between texture and critical current density was found here. But from other investigations it is known that high critical current densities can only be obtained using distinctly textured specimens. The sample length for texture investigations was 50 mm. The gauge length for determination of the j_c -value is only 10 mm. Because of the short gauge length inhomogeneities along the sample length have a greater effect on the j_c -values. The variation of the FWHM values is 20% that of the j_c -values, however, is 50%. The j_c -values are very sensitive against inhomogeneities in the microstructure, hindering the current flow.

For the characterisation of the texture development in dependence on technological steps at the preparation of HTSC-composite conductors the determination of the half-width FWHM from the psi-scan or for one-phase specimens the determination of the Lotgering-factor is appropriate, if only a c-axis texture exists. The measurement of pole figures is necessary to determine, whether a rotation symmetry occurs or an orientation of the (a,b)-directions exists. The use of omega-scan to determine the half-width is not useful, the goniometer unit is intended and optimised for phase analysis and therefore the secondary monochromator cannot be relinquished.

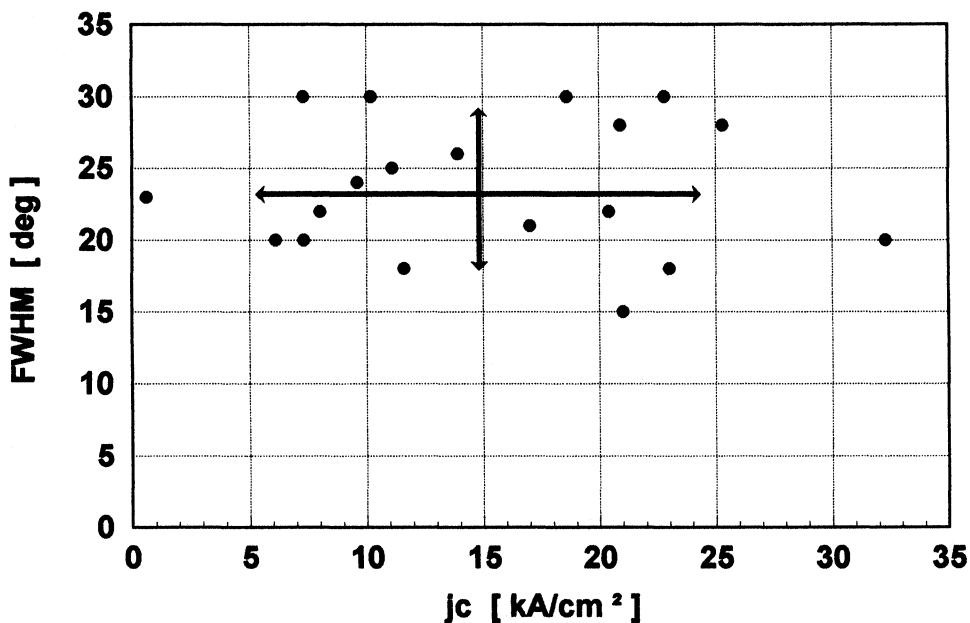

Figure 8 FWHM-values of specimens with different critical current densities in monofilamentary Ag sheathed tapes of BiPbSrCaCuO-HTSC.

References

- Aksenova, T. D., Bratukhin, P. V., Shavkin, S. V., Antipova, E. V., Khlebova, N. E. and Shikov, A. K., *et al.* (1992). Texture formation during heat treatment of laminated composites based on a Bi ceramic in a silver cladding. *Superconductivity*, **5**, 2007–2016.
- Chateigner, D., Germi, P. and Pernet, M. (1993). Texture analysis in films by reflection method principal and aspects and application to YBaCuO on (100)-MgO. Abstract ICOTOM 10, Clausthal, 65.
- Chen, B., Rodriguez, M. A., Misture, S. T. and Snyder R. L. (1992). Direct observation of texture YBa₂Cu₃O_{7-δ} crystal growth from the melt. *Physica C*, **198**, 118–124
- Chew, N. G., Goodyear, S. W., Humphreys, R. G., Satchell, J. S., Edwards, J. A. and Keene, M. N. (1992). Orientation control of YBa₂Cu₃O₇ thin films on MgO for for epitaxial junctions. *Applied Physics Letters*, **60**, 1516–1518.
- Field, M. and Merchant, M. E. (1949). Reflection method of determining preferred orientation on the Geiger-counter spectrometer. *Journal of Applied Physics*, **20**, 741–745.
- Gleitsmann, U., Liu, W. P., Park, N. J. and Bunge, H. J. (1990). Magnetic texturing of Y-Ba-Cu-O superconductors. Abstract Hauptversammlung 1990 Deutsche Gesellschaft für Materialkunde, (in German).
- Grasso, G., Perin, A., Hensel, B. and Flükiger, R. Pressed and cold rolled Ag-sheathed Bi(2223) tapes. *Physica C*, in print.
- Hwang, D. M., Ravi, T. S., Ramesh, R., Siu-Wai Chan, Chen, C. Y. and Nazar, L., *et al.* (1990). Application of a near coincidence site lattice theory to the orientations of YBa₂Cu₃O_{7-x} grains on (001) MgO substrates. *Applied Physics Letters*, **57**, 1690–1692.
- Iijima, Y., Onabe, K., Futaki, N., Tanabe, N., Sadakata, N. and Kohno, O., *et al.* (1991). a-b plane aligned YBa₂Cu₃O_{7-x} thin film tapes. Proceedings of the 4th International Symposium on Superconductivity, (1991), Tokyo.
- Itskovich, R. Yu., Kvichko, L. A., Kotok, L. A., Logvinova, S. E., Rozenberg, G. Kh. and Semnozhenko, V. P., *et al.* (1994). A modified method for obtaining highly textured YBaCuO ceramics. *Superconductor Science & Technology*, **7**, 47–51.
- Kallend, J. S., Schwarz, R. B. and Rollett, A. D. (1991). Resolution of superimposed diffraction peaks in texture analysis of a YBa₂Cu₃O₇ polycrystal. *Texture and Microstructure*, **13**, 189–197.
- Knorr, D.B. and Livingston, D. J. (1989). Texture analysis of magnetically aligned RbBa₂Cu₃O_{7-x} by the pole figure technique. *Superconductivity Science & Technology*, **1**, 302–306.
- Laderman, S. S., Taber, R. C., Jacowitz, R. D., Moll, J. L., Eom, C. B. and Hylton, T. L., *et al.* (1991). Resistive loss at 10 Ghz in c-axis-aligned in-situ-grown YB₂Cu₃O₇ films. *Physical Review*, **B 43**, 2922–2933.
- Liu, W. P., Park, N. J. and Bunge, H. J. (1990). Textures in ceramic superconductors. *Textures and Microstructures*, **13**, 41–50.
- Lotgering, F. K. (1959). Topotactical reactions with ferrimagnetic oxides having hexagonal crystal structures. *Journal of Inorganic and Nuclear Chemistry*, **9**, (1959), 113–123.
- Malik, M. K. (1988). Texture formation and enhanced critical currents in YBa₂Cu₃O₇. *Applied Physics Letters*, **52**, 1525–1527.
- Moore, R. H. (1988). The relation of YBaCuO properties to densification technique. Research Update 1988, Ceramic Superconductor II, publ. by Americ. Ceramic Soc.
- Moeckly, B. H., Russek, S. E., Lathrop, D. K., Buhman, R. A., Li, J. and Mayer, W. J. (1990). Growth of YBa₂Cu₃O₇ thin films on MgO. The effect of substrate preparation. *Applied Physics Letters*, **57**, 1687–1689.
- Neumüller, H. W., Wilhelm, M., Fischer, K., Jenovelis, A., Schubert, M. and Rodig, C. (1994). Processing and properties of 2223 BiPbSrCaCuO silver sheathed tapes. *Advanced in Cryogenic Engineering*, **40**, 139–146.
- Okado, M., Okayama, A., Matsumoto, T., Aihare, K., Matsuda, S. and Ozawa, K. (1988). Neutron diffraction study on preferred orientation of Ag-sheathed Y-Ba-Cu-O superconductor with J_c=1000–3000 A/cm². *Japanese journal of Applied Physics*, **27**, L1715–L1717.
- Osamura, K., Takayama, T. and Ochiai, S. (1989). Effect of cold-working on the critical current density of Ag-sheathed Ba₂YC₃O_{6+x} tapes. *Superconductor Science & Technology*, **2**, 111–114.
- Sekine, H., Ogawa, K., Inoue, K., Maeda, H. and Numata, K. (1989). Metallurgical studies and optimization of critical current density in Bi-(Pb)-Sr-Ca-Cu-O superconductors. *Japanese Journal of Applied Physics*, **28**, 1185–1188.
- Schulz, L. G. (1949). A direct method of determining preferred orientation of a flat reflection sample using a Geiger counter X-ray spectrometer. *Journal of Applied Physics*, **20** 1030–1033.