

Retraction

Retracted: GRUBin: Time-Series Forecasting-Based Efficient Garbage Monitoring and Management System for Smart Cities

Computational Intelligence and Neuroscience

Received 3 October 2023; Accepted 3 October 2023; Published 4 October 2023

Copyright © 2023 Computational Intelligence and Neuroscience. This is an open access article distributed under the Creative Commons Attribution License, which permits unrestricted use, distribution, and reproduction in any medium, provided the original work is properly cited.

This article has been retracted by Hindawi following an investigation undertaken by the publisher [1]. This investigation has uncovered evidence of one or more of the following indicators of systematic manipulation of the publication process:

- (1) Discrepancies in scope
- (2) Discrepancies in the description of the research reported
- (3) Discrepancies between the availability of data and the research described
- (4) Inappropriate citations
- (5) Incoherent, meaningless and/or irrelevant content included in the article
- (6) Peer-review manipulation

The presence of these indicators undermines our confidence in the integrity of the article's content and we cannot, therefore, vouch for its reliability. Please note that this notice is intended solely to alert readers that the content of this article is unreliable. We have not investigated whether authors were aware of or involved in the systematic manipulation of the publication process.

Wiley and Hindawi regrets that the usual quality checks did not identify these issues before publication and have since put additional measures in place to safeguard research integrity.

We wish to credit our own Research Integrity and Research Publishing teams and anonymous and named external researchers and research integrity experts for contributing to this investigation.







The corresponding author, as the representative of all authors, has been given the opportunity to register their agreement or disagreement to this retraction. We have kept a record of any response received.

References

- [1] D. Mishra, S. L. Vajire, S. Saxena et al., "GRUBin: Time-Series Forecasting-Based Efficient Garbage Monitoring and Management System for Smart Cities," *Computational Intelligence and Neuroscience*, vol. 2022, Article ID 2538807, 14 pages, 2022.

Research Article

GRUBin: Time-Series Forecasting-Based Efficient Garbage Monitoring and Management System for Smart Cities

Dhaneshwar Mishra ^{1,2} **Sujal Laxmikant Vajire** ^{1,2} **Siddhant Saxena** ³
Punit Gupta ⁴ **Dinesh Kumar Saini** ⁴ **Ashish Kumar Srivastava** ^{1,2}
and **G. Madhusudhana Rao** ⁵

¹Department of Mechanical Engineering, School of Automobile, Mechatronics, and Mechanical Engineering, Manipal University Jaipur, Dahmi Kalan 303007, Jaipur, Rajasthan, India

²Multiscale Simulation Research Center (MSRC), Manipal University Jaipur, Dahmi Kalan 303007, Jaipur, Rajasthan, India

³Department of Information and Technology Engineering, School of Computing and Information Technology, Manipal University Jaipur, Dahmi Kalan 303007, Jaipur, Rajasthan, India

⁴Department of Computer and Communication Engineering, School of Computing and Information Technology, Manipal University Jaipur, Dahmi Kalan 303007, Jaipur, Rajasthan, India

⁵Bule Hora University, Bule Hora, Ethiopia

Correspondence should be addressed to Punit Gupta; punitg07@gmail.com and Dinesh Kumar Saini; dksssohar@gmail.com

Received 16 March 2022; Revised 20 April 2022; Accepted 12 May 2022; Published 7 June 2022

Academic Editor: Vijay Kumar

Copyright © 2022 Dhaneshwar Mishra et al. This is an open access article distributed under the Creative Commons Attribution License, which permits unrestricted use, distribution, and reproduction in any medium, provided the original work is properly cited.

The waste management of an evolving smart city environment is one of the most important tasks as the living conditions and health of the population depend on proper waste management. Currently deployed systems are failing to monitor the garbage production as they use IoT-based pipelines to monitor the production in a locality, but often the device is used to get destroyed by the frequent use of dustbin. This leads to an increase in expenditure and affects the sustainability of the system. In this work, we propose an efficient and scalable garbage monitoring and collection methodology based on time-series forecasting techniques. The proposed system is also cost-effective because of the iterative deployment of rented IoT sensors, which are used to collect time series format data and then used to train the forecasting module to learn the temporal representation of the data that can produce accurate results for monitoring the fill-up time of the garbage collector. We also propose an efficient collection in-routing technique based on the ranking of bin stations on the basis of temporal and spatial data of the fill-up time and route location to minimize the collection time by making an efficient routing algorithm for garbage collection. This concept of garbage collection will be very useful for smart city planners.

1. Introduction

The concept of smart cities is generally understood as the creation of a modern-day high-tech infrastructure in tandem with the usage of smart technology to facilitate its functioning, but often a very important facet of a sustainably built city is overlooked. This important facet of a sustainably built city, which is often overlooked, includes clean energy resource, fluent supply chain, and most importantly a well-constructed waste management system. Today, having an efficient waste management system has become a topic of

paramount importance, with its negligence leading to serious repercussions such as long-term health and hygiene problems, stunted economic growth, adverse effects on climate, and death of the natural ecosystem of the smart city. Waste management can be understood as the process of collection, separation, transportation, and proper segregation or eradication of the waste so that it does not hinder the sustainability of the city and does not affect its natural ecosystem. The concept of waste management is more relevant in urban areas due to the high population and their dependence on packaged products. The presence of a dense

population in cities can be attributed to the migration of the masses towards cities in search of employment and an overall better quality of life, and this migration of the masses is thus contributing to the problem of the large waste generation in these smart cities heavily by rendering the traditional waste management systems obsolete. It has been predicted that due to increased urbanization and economic growth, global waste generation will increase by 70% in the next 30 years [1]. This increase in waste is contributed by all sectors of the society that produce different types of waste based on their source, which also results in the implementation of different ways for its disposal.

The sources of waste in modern-day cities can be classified into various sectors such as the waste generated from residential areas, from institutions (schools, hospitals, and other institutions in the city), from the transportation facilities (rail, road, air), from constructions, and from industrial sector (Figure 1). High-population residential regions, which include individuals and families, generate bulk amounts of residential waste. This residential waste contains leftover food, paper, plastic, leather and textile, glass, metals, bulky electronic items, and batteries. Industrial waste contributes a huge percentage to the entire waste generation. The main entities contributing to this sector of waste generation are light and heavy manufacturing sites, power, and chemical plants. They generally produce waste that is highly toxic and hazardous in nature. There is a need to deal with these kinds of waste with proper care to avoid contamination. Industrial waste varies according to the population, geography, and topography of a region, as well as the methodologies used in industries for making the products. The waste produced during construction and demolition activities can also be hazardous in nature, thereby requiring proper attention in disposal and management. The waste generated from the commercial and service institutions such as schools, hospitals, and shopping malls mainly includes cardboard, paper, metals, plastics, and food particles. They are one of the most frequent waste generators as they generate waste every day and in large amounts. The waste generated from healthcare institutions contains amounts of hazardous chemical and radioactive waste. The disposal of these hazardous wastes is a matter of high priority and concern as it contains toxic drugs and harmful infectious pathogens. Agricultural wastes are mostly biodegradable and can be reused and recycled to be used in many alternative products, such as manure and food for cattle or for the generation of natural gas, but with increasing population and higher demand for food and agriculture, the leftover or unusable livestock and by-products of agriculture are also becoming a matter of concern. The management of such vast categories of waste is of utmost importance to maintain the sustainability of a smart city, and the accumulation of waste in cities also adds to the global waste, which when considered together exposes a larger fatalistic footprint on the planet.

Each year, the world generates 2 billion metric tonnes of municipal solid waste (MSW). East Asia and the South Pacific regions contribute to about $\frac{1}{4}$ of the total waste produced. Per capita waste generation throughout the world

ranges between 0.4 and 4.3 kgs per person per day. It has been observed that high-income countries with well-managed waste management systems account for 1/3 of the world's waste. In low-income countries, over 90% of the waste produced is mismanaged. In India, around 1.4 lakh megatons of MSW is generated daily, around 1.1 lakh megatons of this MSW is collected, and only 35 thousand megatons of MSW is treated. The deficit in the amount of waste being treated in India can be directly associated with the inefficiency in the waste management systems. The amounts and type of waste generated change with time but are majorly dependent on the population, geography, and topography of the particular place. As per estimations, waste dumps would require a land area of around 1400 sq. km by the year 2051, and waste generation projection for 2025 by 2025 from annexure J is provided in Table 1. The proliferation of the COVID-19 in the year 2019 and its resulting pandemic have further highlighted and added to the problem of managing healthcare waste manifolds. Healthcare waste comprises primarily of the waste generated by hospitals, laboratories, and other healthcare facilities [2]. Poor treatment of such waste causes contamination in society. Several countries with the help of the World Health Organization (WHO) issued guidelines that have taken serious steps in tackling this problem. It has been observed that worldwide about 5.2 million people lose their lives from diseases originating from untreated medical waste. Hazardous healthcare waste can be a chemical waste, infectious waste, pathological waste, radioactive waste, pharmaceutical waste, and non-hazardous healthcare waste [3].

Poorly managed waste that can harm has widespread effects on one's health, environment, and prosperity. Poor waste management not only affects the present world but also may accumulate over time and lead to disastrous consequences to the human species as a whole. The short-term effect includes diseases and respiratory problems in human beings and harm to the animals that eat it unknowingly. The long-term effects include loss of fertility of land, loss of animal habitat, and polluted and chemical-fused water. Poor waste management also results in an annual increase in greenhouse emissions by about 10–15%. Current studies suggest that the presence of microplastic causes turbulence in the aqua life, which in turn affects the food chain and inevitably leads to global warming. Around 75% of the total plastic waste ends up in water bodies [4]. Poor waste management also acts as a major resistance to economic growth, tourism, and development [5]. It creates a major hurdle for government institutions, which are expected to deal with the alarming increase in waste generation, which is why waste management has become a crucial problem faced by the entire world; therefore, a proper and effective waste management system is essential for developing countries and cities. The advancement of technology and networking capabilities has enabled humankind to solve various major problems through the implementation of various technological resources. One such technology that has been a fascinating study and has emerged as a frontrunner in creating more proficient waste management system is Internet of things (IoT).

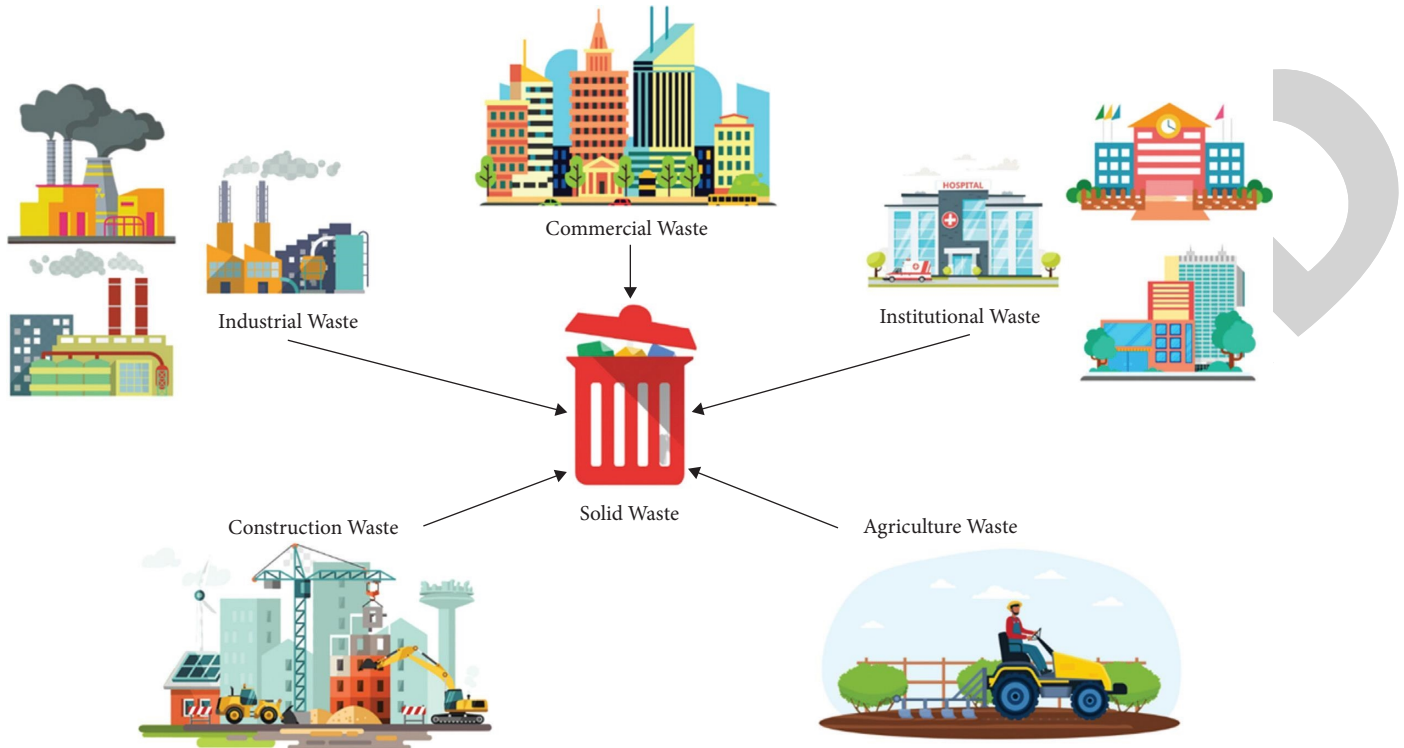

FIGURE 1: Illustration of type of waste generated in a smart city.

TABLE 1: Waste generation projection for 2025 by income.

Region	Current available data			Projections for 2025 (from annex J)			
	Total urban population (millions)	Urban waste generation		Projected population		Projected urban waste	
		Per capita (kg/capita/day)	Total (tons/day)	Total population (millions)	Urban population (millions)	Per capita (kg/capita/day)	Total (tons/day)
Lower income	343	0.60	204,802	1,637	676	0.86	584,272
Lower middle income	1,293	0.78	1,012,321	4,010	2,080	1.3	2,618,804
Upper middle income	572	1.16	665,586	888	619	1.6	987,039
High income	774	2.13	1,649,547	1,112	912	2.1	1,879,590
Total	2,982	1.19	3,532,256	7,647	4,287	1.4	6,069,705

Internet of things (IoT) is a technological apparatus by which the transfer of data for the wide range automated implementations can take place [6, 7]. Internet of things (IoT) offers a wide gamut of solutions to solve important and consequential real-world problems. A lot of new research is being done in the field of the Internet of things (IoT), specifically, to increase efficiency and reduce unnecessary expense and human mismanagement by automating and controlling the task without human intervention. It contributes to increasing the accuracy of the desired results and saving valuable time and money with the use of technology. IoT helps in compensating the gap in network-based technologies that collect data from real-world observations and provide insights to improve the lives of people. Thus, IoT adds productivity and saves costs in many areas. These

IoT-based systems can have applications in smart cities to manage various aspects such as health care, security systems, and waste management [8–10]. The implementation of IoT has offered many solutions to the waste management crisis, and one such leading area of innovation in improving waste management is the application of smart bins.

Smart bins are an economical solution for saving time and money using smart waste collection bins and systems equipped with fill-level sensors and integrated with the command center. As smart transport vehicles go only to the filled containers or bins. It reduces infrastructure, operating, and maintenance costs. There are few works available in the literature on the waste management systems and applications of different sensors and actuators that can be helpful in calculating the optimal route for the garbage

collecting vehicles. Reference [11] proposed a new framework to monitor solid waste in an optimized way reducing the overall cost of the operation and prevention emissions. Accelerometer, load cell, and different sensors are used for collecting information regarding bin, and collected information is sent to the control station using ZigBee Pro and GPRS communication. The data are further used to train the programs for efficient routing. Thus, the new framework optimizes the waste management process while reducing the cost and preventing GhG emissions. Reference [12] discussed the modelling of wireless sensor networks (WSNs). These WSNs communicate if the bins are filled or unfilled with the help of a central monitoring station. Wireless monitoring unit (WMU) is installed in bins, and its sensors update the data in the wireless access point unit (WAPU). The data on the status of bins are monitored through an application. The life expectancy of the wireless monitoring unit and wireless access point unit is discussed with in-depth study, and a comparison between system and manual reading is done with respect to wireless quality and surface-level attainment. Reference [13] in their paper "Efficient IOT Based Smart Bin for Clean Environment" in 2018 introduced some more sensors and proposed efficient waste disposal and management system primarily for smart cities. Internet of things (IoT) can be used in modern smart cities (MSCs) creating an advanced system for waste management. It is basically a smart system consisting of sensors and actuators with an intelligent system (IS) to monitor and alert the authorities and corporations using automated alerts. Reference [14] proposed a "Smart Bin Management System" at SEEDA-CECNSM to tackle the problem of the overflow of garbage bins, which causes unhygienic conditions leading to diseases and infections using IoT. With the use of microcontrollers and ultrasonic sensors, the level of garbage can be estimated. Microcontroller Arduino is used with various sensors such as pressure, temperature, sonar, and Libelium SX1272 for connectivity. This project discusses the LoRa protocol, which has long-distance connectivity with low-power consumptions, which bring down the total budget and increase the communication distance. Few studies were done towards eliminating human contact with the garbage bin to improve hygiene and reduce the spread of diseases by making the movable and self-opening smart bin, and [15] discusses the focus of having sensors rather than human participation, which is the use of smart bins using an ESP8266 module that has two main pins, trigger pin and echo pin. An ultrasonic sensor is also placed on the lid of the smart bin, which detects objects over it. The lid of the smart bin will automatically open if a user carrying trash comes into the sensing area eliminating the direct contact with the trash bin and resulting in maintaining better hygiene. Once the bin is filled to the brim, the information is sent through a Raspberry Pi node. Reference [16] discusses the concept of IoT, and their smart bin solution with a Web application enables operators to know real-time cleanliness status. They propose the use of a colour sensor and an automated guided car (AGV), which is a robotic garbage collector in addition to a solar-powered infrared

sensor installed in a smart bin. Arduino UNO with TCRT5000 sensor and L298N motor was used to track path and move in the same direction, and Raspberry Pi3 B+ module with HC-SR04 sensor and SG90 Servo motor is used in the smart bin named e-TapOn. This will make the process of garbage collection much more efficient. Reference [17] discusses a smart bin system using IoT cloud-based sensors and actuators. The ultrasonic sensor was used to identify the level of garbage in the bin, and ESP8266 Wi-Fi module with Arduino was used to send the collected data to a public cloud environment such as AWS, which further alert the local authority and were also used for finding the best route for garbage collecting vehicles. The proposed approach was designed to create an end product where the product design was modelled in a 3D modelling software and printed using a 3D printer. Reference [18] in their paper talk about a way to improve waste management by providing an electronic system utilizing radio frequency identification at the bin level. An application that converts the weight into points then stores it on a smart card resulting in an increase in the utilization of bin making waste management effective and efficient while spreading awareness in citizens. The waste is tracked using an RFID-based system integrating the Web information at the host server, and an online platform has been introduced where users can log in to check their total points, which can be redeemed for products and services. Reference [19] discusses features of a smart bin that can segregate metal and non-metal waste with the help of an RLC circuit, which is activated only in the proximity of the user, and the purpose of the RLC metal detector was to separate metal and non-metal to reuse and recycle the metal. NodeMCU with ESP8266 Wi-Fi module was used to send the real-time status of the bin to the cloud. They also discuss a mathematical model to find the most optimal location to place the bins. Reference [20] proposed a smart movable bin, which can automatically collect the garbage from the user by sensing his/her vicinity to the bin, via the use of a mobile phone a user can send a message to the GSM module of the smart bin, which activates the microcontroller, and the smart bin moves on a pre-programmed path and collect the trash from the user from his location preventing physical interaction of the user with the bin and improving hygiene. Along with this feature, the host is also notified when the bins are full to the concerned authorities. Further machine learning, deep learning, and artificial intelligence of things were introduced, and [21] in their paper discusses the smart bin mechanism, which is based on the artificial intelligence of things (AIoT). The smart bin mechanism (SBM) works on the concept of reduce, recycle, and reuse. The SBM has three main components trash bins, collecting vehicles, and generated database, and a fuzzy expert system (FES) is used to select the best site where the bin should be installed based on the space and population density in the area in real time. The smart bin mechanism has access to the conditions of the bins and avoids overflow of the bins. This system can reduce the labour costs and energy of the system. Reference [22] suggested an intelligent mechanism that guides garbage trucks to collect the garbage from

specific areas where the bin is almost filled. A machine learning-based approach has been developed to gather information about waste generation patterns to predict the time of when a particular bin will get filled using linear regression. Ultrasonic sensor and IR sensor are used to send data to Arduino and Raspberry Pi once the bin is filled, which then sends an alert via email and text to the concerned authorities, and the data are then sent to the cloud as a training data set for machine learning model to improve the accuracy of the linear regression algorithm and make further predictions. This would make the process more efficient and save unnecessary travel of garbage collecting vehicles, which will reduce air pollution and fuel consumption. Reference [23] in their paper discussed a unique smart waste management system that is based on technologies such as blockchain and the Internet of things in smart bins. This system rewards people for proper disposal of the waste. The difficulties faced in tracking and monitoring are discussed and resolved with the use of blockchain technology by connecting decentralized networks with IoT-based sensors. The experiment has been performed on various test networks such as the matic chain and binance smart chains. This project achieves the goal of being transparent, traceable, and scalable. Reference [24] proposes an efficient automated waste segregation model. They plan to achieve this with the help of the convolutional neural network (CNN) by capturing images of the waste and segregating it into biodegradable and non-biodegradable waste using computer vision, a pre-trained dataset was used to extract features, and the tensor flow technique was used to train the model. The proposed system eliminated the physical efforts required for waste separation, which will reduce the spread of infection and disease. Reference [25] discusses the use of deep learning and the Internet of things to give an agile solution for waste management. The proposed model uses the camera for image acquisition, and the pre-trained machine learning model is used to analyse the image and put the waste into an indigestible or digestible trash box; accordingly, biodegradable and non-biodegradable waste is classified using CNN. The IoT enables real-time data updates from anywhere using the Internet, and in case Internet connectivity becomes an issue, Bluetooth aids in short-range data monitoring through the mobile application system that is also introduced. Their CNN model has about 95.3% waste classification accuracy, and the system usability scale was 86%. Reference [19] proposed an E-bin, which would contain a pair of light-emitting diode (LED) displays. The total amount of waste accumulated is indicated by the first display, while the display will exhibit the highest cost for which the waste can be sold for, to various entities and organizations who would employ the waste effectively. The E-bin operates on a CNN ResNet algorithm, which processes the captured image to segregate the waste into biodegradable and non-biodegradable articles. It was observed that the accuracy of the employed algorithm is in the range of 94 to 96 percentages. Reference [26] proposed two approaches for the detection of the various types of waste containers. The first approach made use of feature

descriptors or more accurately a vector of locally aggregated descriptors (VLADs). This approach, however, failed to reproduce the desired results. The other approach used a convolutional neural network (CNN)—you only look once (YOLO), which produced an accuracy of about 90 percent.

In most of the AI and IoT-enabled techniques for waste management available in the literature (Table 2), the major limitation is that the IoT device gets destroyed in some period of time. This makes the system dysfunctional for the purpose, for which it is being designed. This work proposes a data-centric approach that utilizes the minimum expenditure on the IoT infrastructure and collects time-series data iteratively; therefore, the temporal representation of the data is learned to predict the timestamps of the stations on the basis of previous correlation in the time-series data. In this approach, time-series forecasting of garbage collectors is predicted to minimize the cost and time taken for garbage collection from a large number of sites. This work also proposes an efficient routing path finding algorithm on the basis of spatial and temporal information in the graph of the city. The approach discussed here in this work is unique in the sense that it works on the basis of time-series data rather than depending on regular input from the IoT device embedded in the bins, which not only reduces the cost but also makes the system reliable. The enrooting for the waste collections is also suggested based on the network of bins, their geographical locations, and the information gathered through the time-series data-based machine learning model. The authors are of the view that this cost-effective garbage monitoring system will make the waste collection more efficient.

2. Proposed Waste Management System

Based on time-series forecasting approaches, we propose a robust and cost-effective garbage monitoring system for a large-scale smart city project in this study. Existing approaches are less reliable in terms of garbage monitoring, and the proposed system is highly cost-effective for the long-term sustainability of large-scale production. Existing techniques, on the other hand, recommend monitoring garbage pickup using IoT sensors, which is both expensive and inefficient in terms of sustainability, because waste disposal frequently destroys equipment, resulting in a full failure of the management system [34]. The methodology provided in this research, on the other hand, minimizes the cost of smart bin station deployment and maintenance by using phase-wise iterative data collecting, as explained below.

The time-series data of the garbage collector's or station's fill-up time are collected using IoT device sensors, but the main issue with using IoT devices for garbage monitoring is the cost of deploying a device at each station. As a result, we propose an iterative data collection method in which data from a local large density area are collected using rented sensors, and after data collection, the position of a device is phase-wise reallocated. Following that, the time-series data are gathered in the feature-value mapping format and processed to train the machine learning model, as shown in Figure 2 [35]. As a result, we can acquire an approximate temporal curve of the station's fill-up time using forecasting,

TABLE 2: Tabulation of different waste management techniques available in the literature.

References	Technique	Goal/objective and limitations
[11]	IoT-based sensors with Waspote microcontroller and ZigBee Pro communicator	
[12]	IoT-based sensors with MSP430 microcontroller	Reducing the overall cost of operation by finding the best route for garbage collecting vehicles
[13]	IoT-based sensors with Arduino Uno microcontroller	
[14]	Integration of IoT and AWS Google computer engine	
[15]	IoT-based sensors with Raspberry Pi microcontroller	Elimination of human contact by automating the opening and closing of the smart bin
[16]	IoT-based sensors with Raspberry Pi microcontroller	Movable and self-opening and closing smart bin to avoid human interaction and maintain hygiene
[20]	IoT-based movable bin with L298 N motor driver	
[21]	Integration of IoT and machine learning algorithm (fuzzy logic)	Select the best site for bin installation based on real-time space and population density in the area
[22]	Integration of IoT and machine learning algorithm (linear regression)	Predict the fill-up time of a particular bin
[18]	Integration of IoT and (RFID) radio frequency identification	Increase utilization of bin by rewarding points based on weight
[23]	Integration of IoT and blockchain	Waste classification into biodegradable and non-biodegradable waste
[24]	IoT and tensor flow	
[25]		Identification of e-waste and its subsequent categorization
[27]	Faster region CNN	
[28]		Recognition of street litter and categorization
[29]		Detection of garbage for street cleanliness evaluation
[30]		Separation of biodegradable and non-biodegradable waste
[31]	YOLOv2 and YOLOv3 CNN	Classification of garbage container after detection
[32]	YOLOv3 and YOLOv3 Tiny-CNN	Segregation of waste for recycling and reuse or for disposal
[33]	YOLOv2 CNN	Classifying battery-containing devices, detecting batteries, and recognizing battery structures

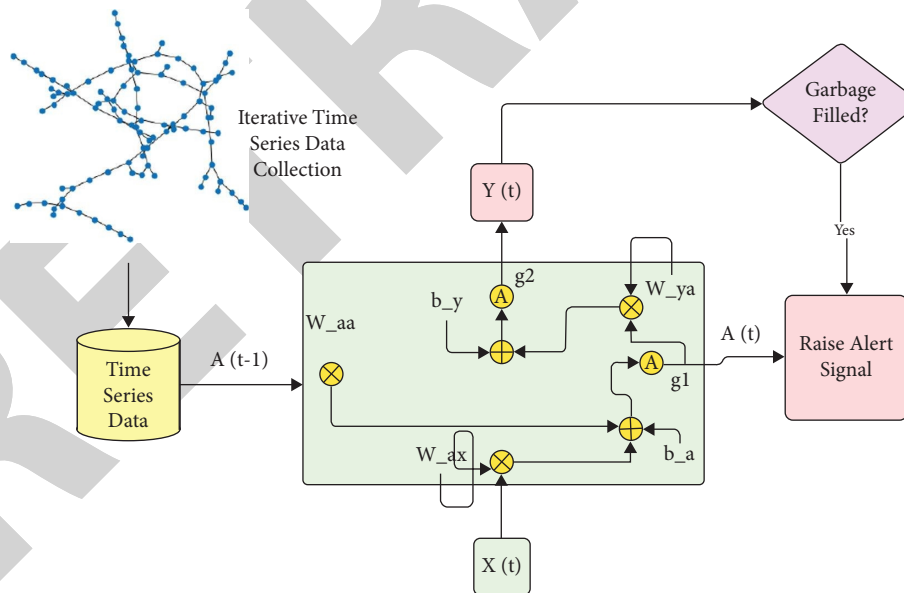

FIGURE 2: Architecture of time-series data forecasting for efficient garbage monitoring.

and we can avoid the permanent deployment of expensive short-term equipment using this phase-wise iterative deployment of IoT devices.

3. GRUBin Architecture

The monitoring of the garbage in a population-wise dense and evolving location is a very difficult and inefficient

process. However, the proposed architecture of GRUBin is inspired by the time-series forecasting of data collected by the iterative deployment of IoT sensors; therefore, in this section, we describe the architecture of the forecasting module based on recurrent neural networks (RNNs) comprised of gated recurrent units as the monitoring has to be done in spatially distributed bins or stations; hence, we use “many-to-many” input-output model for the deep RNN to

embed the temporal training data of bins and output different timestamp for each of the located garbage collectors; also, as the number of sites and timestamps to be calculated is large, we propose the use of long short-term memory (LSTM)-based architecture for large-scale monitoring system, which comprises of recurrent units as hidden states and forecast for a large number of input timestamps [36].

The many-to-many LSTM architecture used for the time-series forecasting of garbage bins is described in Figure 3(a).

For each of the stations at timestep t , the hidden state A (t) and output Y (t) are updated as below (1) and (2):

$$A(t) = g1(W_{aa}A(t-1) + W_{ax}X(t) + b_a), \quad (1)$$

$$Y(t) = g2(W_{ya}A(t) + b_y), \quad (2)$$

where W_{ax} , W_{aa} , W_{ya} , b_a , and b_y are weights that are shared temporally and $g1$ and $g2$ are tanh activation functions. However, for the calculation and updation of weights of the recurrent neural networks, the loss function L (3) is calculated for all time steps and is defined on basis of loss at every time step. The training of these recurrent neural networks is based on backpropagation in time, which is done at each point in time. At timestep T , the objective loss is minimized by calculating the gradient (4) with respect to weight matrix W .

The flowchart in Figure 4 describes the workflow of the efficient garbage monitoring system. The garbage station is equipped with IoT sensors that are deployed iteratively, and time-series data are collected until the process of deployment completes, and then, data are processed to format it in feature vector format. After that, a time-series forecasting module is given the input data and the resultant timestamps are used for monitoring and efficient routing.

3.1. Implementation of Time-Series Forecasting Module.

The suggested GRUBin architecture's design principle and development process are illustrated in this section. The block diagram of the designed trash can is shown in Figure 5. The complete process is programmed using a microcontroller designated "ESP8266" node MCU. The microcontroller is connected to an ultrasonic sensor that measures the garbage can's empty level. The ultrasonic sensor is mounted on the top of our prototype. To calculate the garbage bin's empty level, an ultrasound is emitted and received. The microcontroller receives the calculated value. At the bottom of the surface, a load measuring sensor is also installed. This sensor is in charge of calculating the waste's weight in kilograms. Then, database containing the time-series format values is used to train the forecasting model and upload the data to the cloud to provide a distributed real-time monitoring of garbage fill-up.

The time-series forecasting of the garbage fill-up time is implemented in the PyTorch framework [37], which is developed by Meta AI. It provides the basic framework to support the forecasting methodology. The recurrent neural network is composed of many-to-many architecture as

discussed in Section 4, the temporal representation and underlying correlation of data are learned by gated recurrent units as hidden layers in each input-output block, and the loss function (3) is used to train the model to get accurate results as of ground-truth collected by IoT sensors, and the model is trained iteratively until loss is minimized, and the gated recurrent units also help to reduce vanishing gradients problem. The temporal representation is indicated as weights in the neural networks, and the learning of the model in the LSTM-based architecture is done using the backpropagation in time algorithm as described in (4).

$$\text{Loss function: } L(Y' - Y) = \sum_{t=1}^{T_y} L(Y'(t) - Y(t)), \quad (3)$$

$$\text{Backpropagation through time: } \frac{\delta L(T)}{\delta W} = \sum_{t=1}^T \frac{\delta L(T)}{\delta W} \Big|_{(t)}. \quad (4)$$

3.2. Efficient Routing for Garbage Collection. The garbage monitoring is crucial for the timely disposal of waste products, but it is not complete until time-series data forecasting predicts the estimated time of garbage fill-up at deployed stations. We propose an efficient garbage collection based on population density, station location, and predicted timestamps. Each station can be regarded as a node in the geo-location graph (G) of the smart city, and each node contains its feature vector. Therefore, this study presents the ranking of bin stations on the basis of the timestamps forecasted by the model and feature vectors. However, garbage bins with sequential timestamps may not be close to each other; hence, the ranked stations are assigned weights, and then, the order-wise shortest path length is calculated. Hence, the shortest path containing the largest sequential length of weights is given the highest priority in the collection process as described in Algorithm 1.

4. Results and Discussion

The efficient garbage monitoring approach discussed in this study is based on time-series forecasting of garbage fill-up timestamps at stationed devices. Forecasting experimentation is performed to forecast the volume fill-up from the garbage station with the passage of time in days, using LSTM-derived architecture, and Figure 6(a) depicts the forecasting of waste volume production, with a training set of 10 days, and these data are divided into train and test time sets. However, because the forecasting model fails to accurately predict the predicted waste fill-up volume on the test set, we decided to expand the training set by producing garbage fill-up data for 25 days.

After increasing the size of the training data, the forecasting model performs a lot better than on the less amount of data as described in Figure 6(b), the forecasting on the test set achieves accuracy up to 93.4 percent, which is quite helpful, and this forecasting module tends to perform more accurate as the actual data. According to Figure 6(b), the

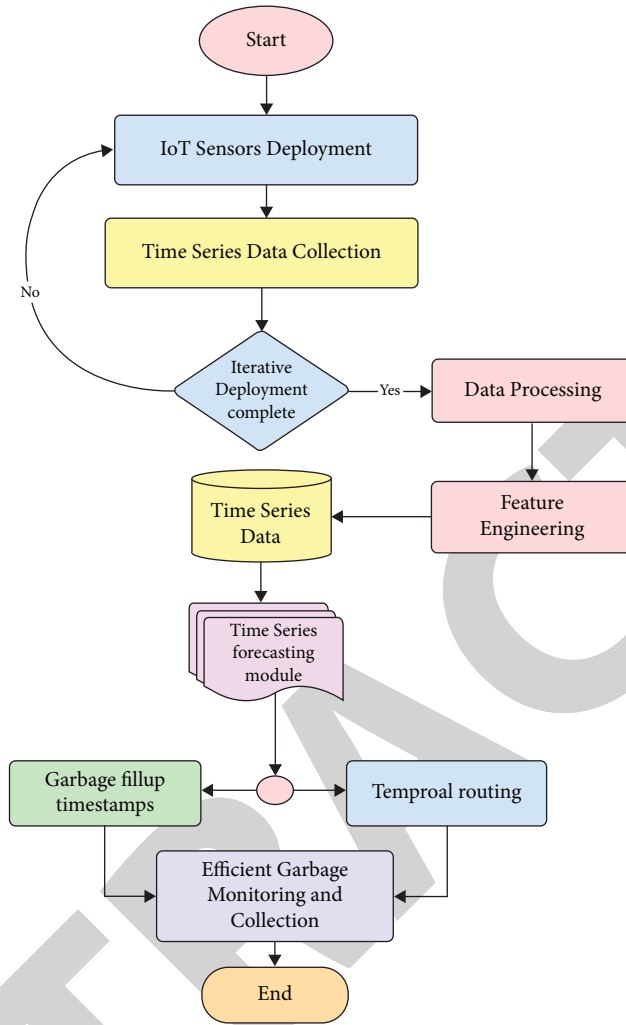

FIGURE 4: Flowchart of GRUBin working principle.

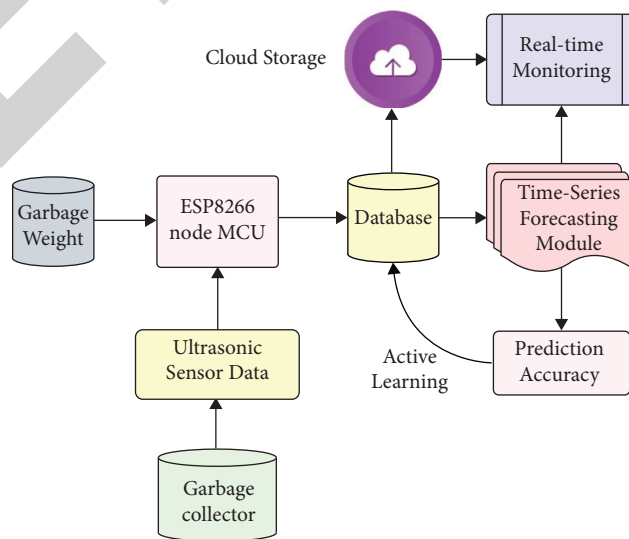

FIGURE 5: Data collection and flow process in the efficient garbage monitoring system.

```

Step 0: Start
Step 1: Init Graph G (V, E), V timestamp rank, E spatial distance (u, v)
Step 2: for v ∈ V in G (V, E):
    distance[v] ← INF
    prev[v] ← NAN
    add v to Q
(2.1): dist[source] ← 0
(2.2): while len(Q) ≠ 0:
(2.3):   u ∈ V ← vertex in Q with min(distance[u])
(2.4):   for n ∈ Neighbor v of u in Q:
(2.5):     alt_path ← distance[u] + len(e ∈ E)
(2.6):     if alt_path < distance[v]:
(2.7):       distance[v] ← alt_path
(2.8):       prev[v] ← u
Step 3: return distance[], prev[]

```

ALGORITHM 1: Efficient routing protocol for temporal ranked stations.

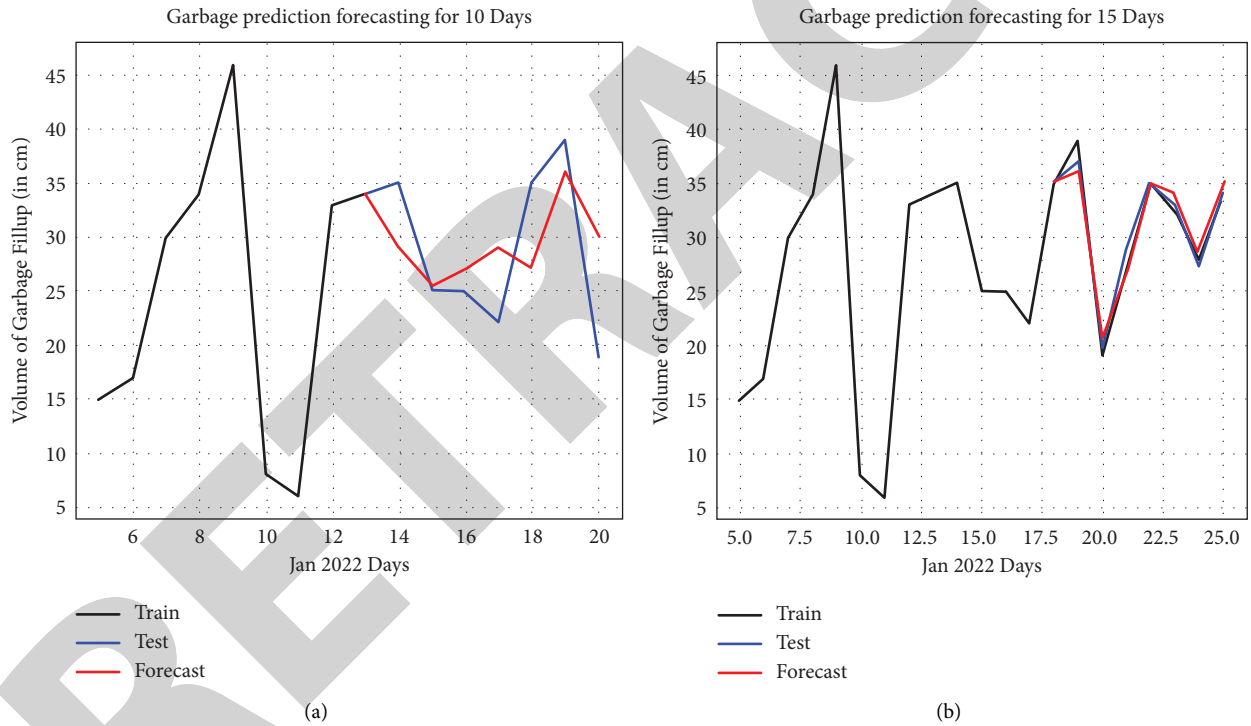

FIGURE 6: (a) Garbage fill-up forecasting for 10 days and (b) garbage fill-up forecasting for 15 days.

TABLE 3: Accuracy analysis and results of LSTM time-series forecasting model.

Training set size (days)	Forecasting set size (days)	Avg. mean absolute error (in cm)	Standard deviation (in cm)
10	2	4.36	0.72
10	4	4.89	0.76
10	7	5.21	0.68
15	2	7.65	0.18
15	4	6.23	1.36
15	7	5.53	1.23
20	2	6.45	3.45
20	4	5.32	2.46
20	7	4.92	0.79
25	2	5.12	3.24
25	4	5.17	0.33
25	7	5.36	0.55

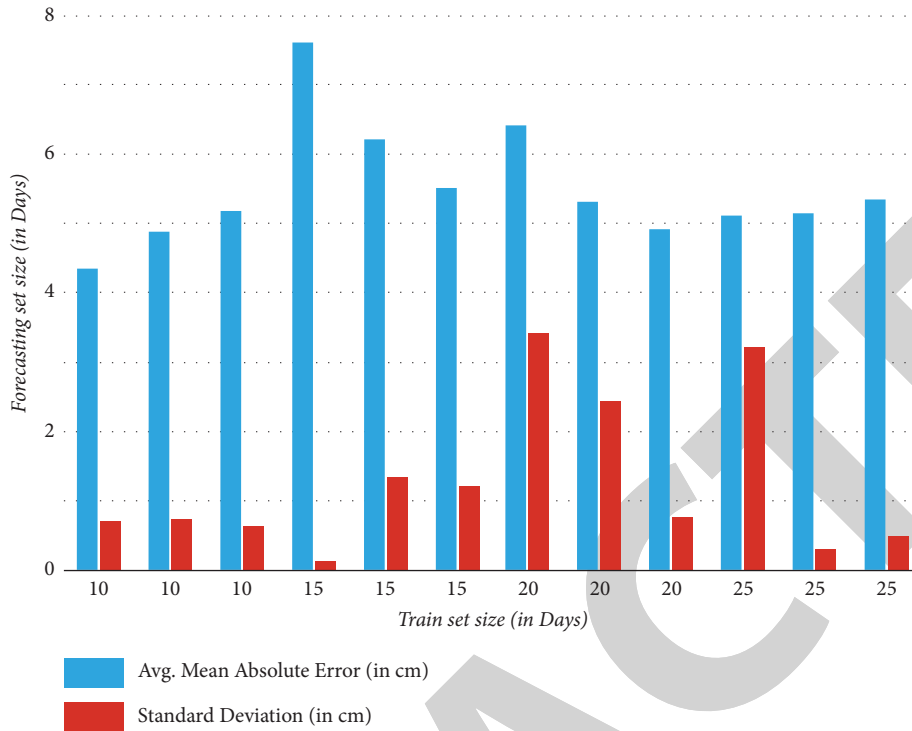

FIGURE 7: LSTM forecasting model accuracy analysis.

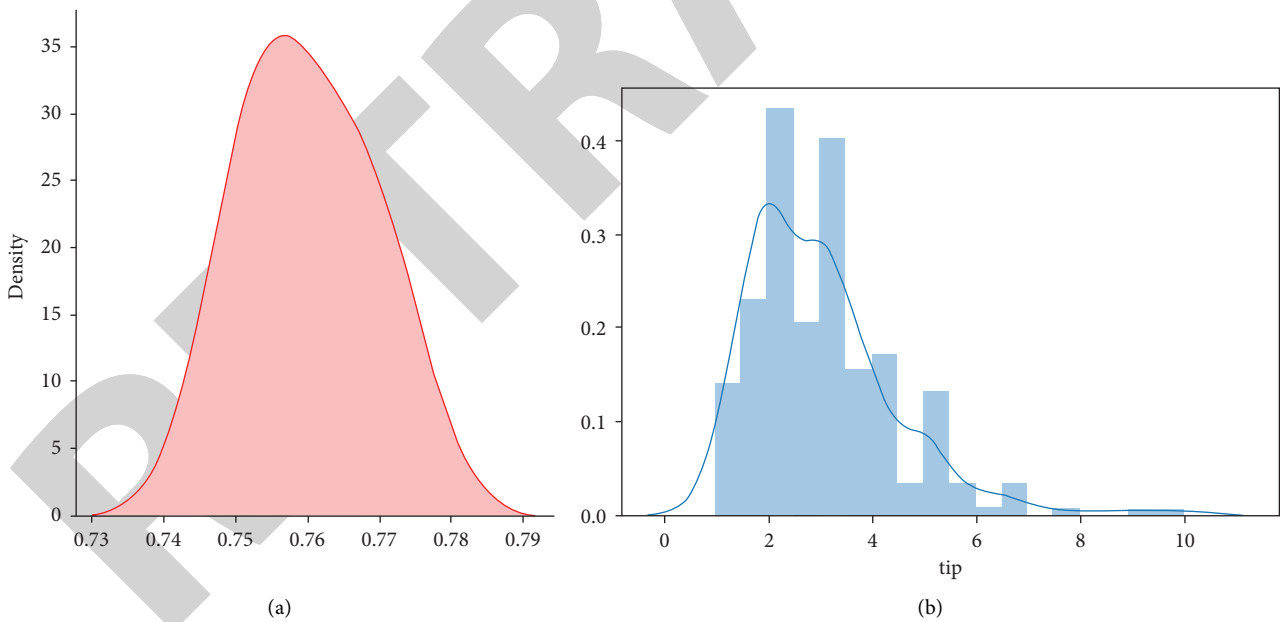

FIGURE 8: (a) Gaussian distribution of the data and (b) garbage fill-up (“tip”) time (hrs) v/s days.

of the survey was to check the feasibility of the system in the regular household environment. We explained to them the current methods used for waste management followed by a theoretical explanation of our system. For a fair survey, our completed application and the trash bin system were shared with the participants, and after a designated period of usage, their feedback and comments on the system were recorded.

The system usability scale survey showed that 47% of the participants strongly advocate our developed system, while 39% of the participants approve our solution. This result clearly validates our solution and highlights that xx% of the participants would recommend and implement our polished architecture. This result substantiates both the importance and the success of our system. On the contrary, 4% of people

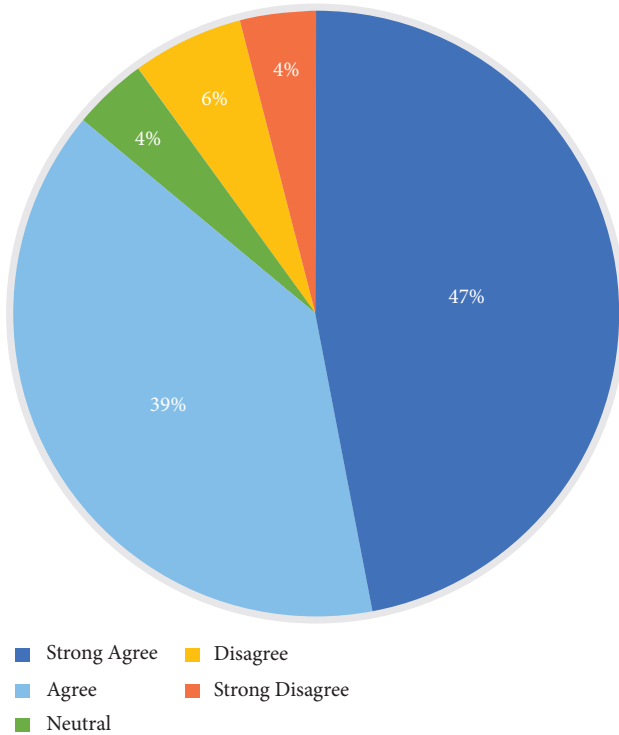

FIGURE 9: A pie chart representation of system usability scale survey.

remain even-handed towards the system and 6% of the participants gave a contradictory response, while 4% of the participants from the survey strongly disagree with our proposed system. It is clear from the SUS survey that the optimistic responses towards our system far outweigh the pessimistic ones. A pie chart representation of the survey results is shown in Figure 9.

5. Conclusion and Future Work

This study presented a cost-effective and highly sustainable approach for garbage collection and monitoring tasks in the smart city ecosystem based on a time-series forecasting methodology. The garbage collection data were collected using the iterative deployment of rented IoT devices and storing the timestamps of garbage collector fill-up time. The proposed methodology in this research takes a data-centric approach. The waste fill-up timestamp time-series forecasting is extremely accurate and cost-effective, and the experimentation shown in the results and discussion section demonstrates that the system [38] is highly scalable and sustainable for a growing population of [39] and smart city ecosystems. This study also provides the efficient collection of garbage from deployed stations [40] using [41] feature vectors of each station as nodes in the city graph with temporal and spatial information to construct the most efficient route to collect garbage from the stations on time. The routing described in this study focuses [31] on temporal data analysis and forecasting to determine the optimum routing for the municipality. This methodology of enrooting for garbage collection can prove to be better

than the distance metrics between station nodes being taken by existing enrooting systems. Therefore, this article provides an end-to-end pipeline for monitoring and collecting waste from trash cans in a cost-effective and long-term manner. This work will be extended and will be made more efficient using graph machine learning methodology, which can be the next frontier in smart monitoring and collection of waste.

Data Availability

No data were used to support this study.

Conflicts of Interest

The authors declare that they have no conflicts of interest.

References

- [1] D. Hoornweg and P. Bhada-Tata, *What a Waste: A Global Review of Solid Waste Management. Urban Development Series; Knowledge Papers No. 15*, World Bank, Washington, DC, USA, 2012, <https://openknowledge.worldbank.org/handle/10986/17388>.
- [2] A. K. Das, M. N. Islam, M. M. Billah, and A. Sarker, "COVID-19 pandemic and healthcare solid waste management strategy – a mini-review," *The Science of the Total Environment*, vol. 778, no. 146220, 2021.
- [3] C. Kenny and A. Priyadarshini, "Review of current healthcare waste management methods and their effect on global health," *Healthcare*, vol. 9, no. 3, p. 284, 2021.
- [4] P. Alam and K. Ahmade, "Impact of solid waste on health and the environment," *International Journal of Sustainable Development and Green Economics (IJSDEG)*, vol. 2, no. 1, pp. 165–168, 2013.
- [5] Y.-C. Chen, "Effects of urbanization on municipal solid waste composition," *Waste Management*, vol. 79, pp. 828–836, 2018.
- [6] P. Gupta, A. Pandey, P. Akshita, and A. Sharma, "2020, IoT based healthcare kit for diabetic foot ulcer," in *Proceedings of the ICRIC*, pp. 15–22, Springer, Jammu, India, 2019.
- [7] P. Gupta, S. Patodiya, D. Singh, J. Chhabra, and A. Shukla, "IoT based smart petrol pump," in *Proceedings of the 2016 Fourth International Conference on Parallel, Distributed and Grid Computing (PDGC)*, pp. 28–32, IEEE, Wagnaghat, India, 2016.
- [8] A. Al-Fuqaha, M. Guizani, M. Mohammadi, M. Aledhari, and M. Ayyash, "Internet of things: a survey on enabling technologies, protocols, and applications," *IEEE Communications Surveys & Tutorials*, vol. 17, no. 4, pp. 2347–2376, 2015.
- [9] K. Pardini, J. J. P. C. Rodrigues, A. Sergei, N. Kumar, and V. Furtado, "IoT-based solid waste management solutions: a survey," *Journal of Sensor and Actuator Networks*, vol. 8, p. 5, 2019.
- [10] M. Marchiori, "The smart cheap city: efficient waste management on a budget," in *Proceedings of the 2017 IEEE 19th International Conference on High Performance Computing and Communications; IEEE 15th International Conference on Smart City; IEEE 3rd International Conference on Data Science and Systems (HPCC/SmartCity/DSS)*, pp. 192–199, Bangkok, Thailand, December 2017.
- [11] M. A. Al Mamun, M. A. Hannan, and A. Hussain, "Real time solid waste bin monitoring system framework using wireless sensor network," in *Proceedings of the 2014 International*

- Conference on Electronics, Information and Communications (ICEIC)*, pp. 1-2, Jeju, Korea, February 2014.
- [12] S. R. J. Ramson and D. J. Moni, "Wireless sensor networks based smart bin," *Computers & Electrical Engineering*, vol. 64, pp. 337-353, 2017.
- [13] S. Murugaanandam, V. Ganapathy, and R. Balaji, "Efficient iot based smart bin for clean environment," in *Proceedings of the 2018 International Conference on Communication and Signal Processing (ICCSP)*, pp. 0715-0720, Melmaruvathur, India, April 2018.
- [14] Ziouzios and M. Dasygenis, "A smart bin implementation using lora," in *Proceedings of the 2019 4th South-East Europe Design Automation, Computer Engineering, Computer Networks and Social Media Conference (SEEDA-CECNSM)*, pp. 1-4, Piracus, Greece, September 2019.
- [15] R. R. Praveen and M. U. Rammohan, D. Sidharth, S. Ambat, and T. Anjali, "IoT Based Smart Bin: A Swachh-Bharat Initiative," in *Proceedings of the 2020 International Conference on Electronics and Sustainable Communication Systems (ICESC)*, pp. 783-786, Coimbatore, India, July 2020.
- [16] M. J. C. Samonte, S. H. Baloloy, and C. K. J. Datinguino, "E-tapon: solar-powered smart bin with path-based robotic garbage collector," in *Proceedings of the 2021 IEEE 8th International Conference on Industrial Engineering and Applications (ICIEA)*, pp. 181-185, Hainan, China, April 2021.
- [17] M. Srinivas, S. Benedict, and B. C. Sunny, "IoT cloud based smart bin for connected smart cities - a product design approach," in *Proceedings of the 2019 10th International Conference on Computing, Communication and Networking Technologies (ICCCNT)*, pp. 1-5, Kanpur, India, July 2019.
- [18] M. H. Abd Wahab, A. A. Kadir, M. R. Tomari, and M. H. Jabbar, "Smart recycle bin: a conceptual approach of smart waste management with integrated web based system," in *Proceedings of the 2014 International Conference on IT Convergence and Security (ICITCS)*, pp. 1-4, Beijing, China, October 2014.
- [19] K. C. Saranya, V. Sujana, B. Abivishaq, and K. Nithish Kanna, "Smart bin with automated metal segregation and optimal distribution of the bins," in *Emerging Technologies for Agriculture and Environment. Lecture Notes on Multidisciplinary Industrial Engineering*, B. Subramanian, SS. Chen, and K. Reddy, Eds., Springer, Berlin, Germany, 2020.
- [20] P. Jana and R. Sen, "GSM controlled location specific garbage collecting Smart-bin," in *Proceedings of the 2019 9th Annual Information Technology, Electromechanical Engineering and Microelectronics Conference (IEMECON)*, pp. 211-214, Jaipur, India, March 2019.
- [21] A. Bano, U. Din Ikram, and A. Al-Huqail, "AIoT-based smart bin for real-time monitoring and management of solid waste," *Scientific Programming*, vol. 2020, Article ID 6613263, 13 pages, 2020.
- [22] J. Baby, H. Singh, A. Srivastava, R. Dhawan, and P. Mahalakshmi, "Smart bin: an intelligent waste alert and prediction system using machine learning approach," in *Proceedings of the 2017 International Conference on Wireless Communications, Signal Processing and Networking (WiSP-NET)*, pp. 771-774, Chennai, India, March 2017.
- [23] M. Paturi, S. Puvvada, B. S. Ponnuru, M. Simhadri, B. S. Egala, and A. K. Pradhan, "Smart solid waste management system using blockchain and iot for smart cities," in *Proceedings of the 2021 IEEE International Symposium on Smart Electronic Systems (iSES)*, pp. 456-459, Jaipur, India, December 2021.
- [24] S. B. K. Parkavi, S. A. R. Kokiladevi, and M. Dharani, "CNN based smart bin for waste management," in *Proceedings of the 2022 4th International Conference on Smart Systems and Inventive Technology (ICSSIT)*, pp. 1405-1409, Tirunelveli, India, January 2022.
- [25] M. Wahidur Rahman, R. Islam, A. Hasan, N. Islam Bithi, M. Hasan, and M. M. Rahman, "Intelligent waste management system using deep learning with IoT," *Journal of King Saud University-Computer and Information Sciences*, vol. 34, pp. 1319-1578, 2020.
- [26] A. Aishwarya, P. Wadhwa, O. Owais, and V. Vashisht, "A waste management technique to detect and separate non-biodegradable waste using machine learning and yolo algorithm," in *Proceedings of the 2021 11th International Conference on Cloud Computing, Data Science & Engineering*, pp. 443-447, Noida, India, January 2021.
- [27] P. Nowakowski and T. Pamula, "Application of deep learning object classifier to improve e-waste collection planning," *Waste Management*, vol. 109, pp. 1-9, 2020.
- [28] P. Ping, G. Xu, E. Kumala, and J. Gao, "Smart street litter detection and classification based on faster R-CNN and edge computing," *International Journal of Software Engineering and Knowledge Engineering*, vol. 30, pp. 537-553, 2020.
- [29] P. Zhang, Q. Zhao, J. Gao, W. Li, and J. Lu, "Urban street cleanliness assessment using mobile edge computing and deep learning," *IEEE Access*, vol. 7, pp. 63550-63563, 2019.
- [30] V. P. Brintha, R. Rekha, J. Nandhini, N. Sreekaarthick, and B. Ishwaryaa, "Automatic classification of solid waste using deep learning," in *Proceedings of International Conference on Artificial Intelligence, Smart Grid and Smart City Applications*, pp. 881-889, Coimbatore, India, January 2019.
- [31] M. Valente, H. Silva, J. Caldeira, V. Soares, and P. Gaspar, "Detection of waste containers using computer vision," *Applied System Innovation*, vol. 2, no. 1, 2019.
- [32] S. Kumar, D. Yadav, H. Gupta, O. P. Verma, I. A. Ansari, and C. W. Ahn, "A novel yolov3 algorithm-based deep learning approach for waste segregation: towards smart waste management," *Electronics*, vol. 10, no. 1, p. 14, 2020.
- [33] W. Sterkens, D. Diaz-Romero, T. Goedemé, W. Dewulf, and J. R. Peeters, "Detection and recognition of batteries on X-Ray images of waste electrical and electronic equipment using deep learning," *Resources, Conservation and Recycling*, vol. 168, 2021.
- [34] S. Mdukaza, B. Isong, N. Dladlu, and A. Abu-Mahfouz, "Analysis of IoT-enabled solutions in smart waste management," in *Proceedings of the IECON 2018 - 44th Annual Conference of the IEEE Industrial Electronics Society*, Washington, DC, USA, October 2018.
- [35] G. Bontempi, S. Ben Taieb, and Y. A. Le Borgne, "Machine learning strategies for time series forecasting," in *Business Intelligence. eBISS 2012*, MA. Aufaure and E. Zimányi, Eds., Vol. 138, Springer, Berlin, Germany, 2013.
- [36] Y. Yu, X. Si, C. Hu, and J. Zhang, "A review of recurrent neural networks: LSTM cells and network architectures," *Neural Computation*, vol. 31, no. 7, pp. 1235-1270, 2019.

- [37] N. Ketkar and J. Moolayil, "Introduction to pytorch," in *Deep Learning with python*, pp. 27–91, Apress, Berkeley, CA, USA, 2021.
- [38] S. A. M. Bhambri and V. Ganesan, "A cost-effective smart E-bin system for garbage management using convolutional neural network," in *Proceedings of the 2021 International Conference on System, Computation, Automation and Networking (ICSCAN)*, pp. 1–6, Puducherry, India, July 2021.
- [39] W. Jiang and J. Luo, "Graph neural network for traffic forecasting: a survey," 2021, <https://arxiv.org/abs/2101.11174>.
- [40] T. Karak, R. M. Bhagat, and P. Bhattacharyya, "Municipal solid waste generation, composition, and management: the world scenario," *Critical Reviews in Environmental Science and Technology*, vol. 42, no. 15, pp. 1509–1630, 2012.
- [41] A. Negro, *Graph-powered Machine Learning*, Simon & Schuster, New York, NY, USA, 2021.

RETRACTED