

Research Article

From Topology Optimization to Complex Digital Architecture: A New Methodology for Architectural Morphology Generation

Kangqiang Lin,¹ Yongpeng He,² Yang Yang,³ and Lei Xiong¹ 

¹School of Architecture and Applied Art, Guangzhou Academy of Fine Arts, Guangzhou 511400, China

²Department of Architecture and Civil Engineering, University of Bath, Bath BA1 3BZ, UK

³Department of Civil Engineering and Transportation, South China University of Technology, Guangzhou, China

Correspondence should be addressed to Lei Xiong; kmt20005@gmail.com

Received 9 May 2021; Accepted 13 July 2021; Published 5 October 2021

Academic Editor: Rahul V. Ralegaonkar

Copyright © 2021 Kangqiang Lin et al. This is an open access article distributed under the Creative Commons Attribution License, which permits unrestricted use, distribution, and reproduction in any medium, provided the original work is properly cited.

Owing to the capacities of generating structural configuration with both reasonable mechanical properties and high material utilization, topology optimization has been widely adopted in engineering design. Although numerous architects have tried to apply topology optimization tools to assist architectural morphology design in practical projects, topology optimization, like other quantitative analysis techniques, has not been systematically incorporated into the architectural morphology design. In this study, by integrating topology optimization toolsets and parametric design theory, combined with multiattribute decision-making analysis, a design method is proposed that could efficiently obtain several architectural structural architectural morphologies with both structural rationality and aesthetic rules and complete the evaluation and performance ranking of alternatives. In this study, the essential architectural application scenarios are divided into surface application scenarios and volumetric application scenarios, and the possible variation range of topology optimization parameters of architectural application scenarios is defined. By iteratively adjusting the influence parameters, diverse results of structural morphology are obtained. It is found that small changes in optimization parameters will bring great differences in topological results. Such a sensitive relationship can be utilized to generate a set of rational topological structures, and these topological results can be regarded as alternatives for architectural morphology design. For the performance evaluation and ranking analysis of alternatives, the application of FANP-TOPSIS multiattribute decision-making model is put forward in this study. The case study shows that this decision-making analysis model is efficient, convenient, and applicable in the architectural morphology design. The results of this study can provide new ideas and key references for scholars and architects in the field of architecture to explore the process and method of architectural morphology design and other related issues.

1. Introduction

Developments in construction industry design software and the maturity of related manufacturing techniques over the past two decades have led to the construction of buildings with complex and eye-catching appearance [1]. Whilst many have received praise and are considered to be iconic landmarks for their region, others are criticized for the lack of harmony between their architectural design and structural considerations. The challenge therefore remains to obtain satisfying designs that can simultaneously embrace architectural operational functions and aesthetic appealing effects, as well as maintaining rational structural performance

[2]. Inspired by structural morphology (Rene Motro, an anthology of structural morphology), which involves form, forces, material, and structures and aiming at developing a structural system with harmony synthesis of these four aspects, architectural morphology is defined by extending the connotation of structural morphology, which simultaneously deals with structural performance, architectural functions, and aesthetical requirement, aiming at developing an architectural system with a balance between these factors.

Topology optimization, a mathematical method to optimize material distribution in a given area according to given conditions and objective index, has attained its popularity in civil engineering and architectural design

owing to its potential to generate rational and aesthetic-artistic morphology [3]. Topology optimization was initially developed for applications in aeronautic and mechanical engineering [4], where the design space represents a continuum of material, and even small savings in weight are significant, for example, by saving fuel on thousands of journeys and/or saving material on thousands of mass-produced products. Amongst the many topology optimization methods that have been developed, common approaches include the solid isotropic material with penalization (SIMP) method [5–7], the (bidirectionally) evolutionary structural optimization (ESO or BESO) method [8, 9], level set methods [10–12], the moving morphable components (MMC) method [13, 14], and the independent continuous mapping (ICM) [15] method. Many of these approaches have been adopted for the application to the architectural morphology problem domain. For the design of bracing systems for high-rise buildings, Beghini et al. [16] proposed a topology optimization framework to integrate architecture and engineering. The generation of optimized shell- and large-scale spatial structures was investigated by Ohmori [17], who developed an extended ESO method, whereas Peng [18] applied the ICM method to designs of dendriform structures with hierarchical topologies similar to tree branches.

Whilst a wide range of literature can be found relating the application of topology optimization methods to architectural design, there still exist a number of gaps that necessitate further investigation, which this paper address. Firstly, researchers usually focus on a particular type of application scenario, such as beams, walls, or large-scale spatial structures, whereas a comprehensive study of how to use topology optimization to generate architectural morphology across many different application scenarios is still missing. Additionally, the relationship between the inputs to a topology optimization and the resulting morphology has not been investigated in detail. This lack of understanding of the sensitivity of the outputs to the inputs is one of the main obstacles preventing the architects from using topology optimization tools in practice. Thirdly, little research has been carried out to discuss and compare the topology and morphology of optimized architectural design from topology optimization in the perspective of aesthetic.

This paper first extracts and classifies the most common architectural scenarios based on their geometrical features and structural properties. It then derives the key parameters that affect the topological results and discusses their relative impact on these results. A methodology combining parametric modelling and topology optimization is then adopted for architectural morphology generation. By making use of the sensitive relationship between the resulting topology and the input parameters for optimization, a single solution, or a cluster of solutions, can be obtained. They are viewed as potential candidates for building designs, thus solving the problem of architectural morphology generation. Finally, a numerical case is adopted to compare morphology of different optimized shell results and provides some basic aesthetic evaluation from architect's perspective.

The outline of this article is as follows. In Section 1, the context of the study and the required background knowledge is presented. In Section 2, the morphology generation procedure is proposed, and the influential parameters are identified. The essential architectural application scenarios are classified in Section 3, along with a discussion on how the influential parameters relate to each architectural application. Section 4 assesses the relationship between optimization parameters and the topological results for each classification, and in Section 5, the specific example of the morphology generation of a shell structure is investigated. Finally, Section 6 highlights the conclusions of the work and discusses the implications for morphology generation in practice.

2. Morphology Generation Methodology

Topology optimization of structure generally involves the addition, subtraction, or elimination of material from within a design domain. Through iterative adjustment of material, the optimal topology, representing the force flow within the domain, will gradually emerge. In addition to having the best mechanical performance, it is often the case that the obtained topology is also highly aesthetic. This successful combination of engineering and art is therefore viewed as a desirable candidate for architectural morphology design. However, there is no guarantee that the configuration produced through topology optimization would always be suitable for direct employment in the next design stage, and usually some modification is necessary, which can be achieved by adjusting the influential parameters.

Before considering how to adjust the influential parameters accordingly, a method for solving the problem of architectural morphology generation via topology optimization is introduced below, and the parameters that play key roles in determining the resulting morphology are considered.

2.1. Influential Parameters. In this paper, topology optimization is used to generate architectural morphology; therefore, the optimization parameters for topology optimization of different structures and structural members are also used as the parameters for morphology generation of them. Some additional parameters are required for the topology optimization, such as load scenarios, boundary conditions, and material properties, which are not directly related to the morphology.

The first parameter to be considered, the design domain, is represented by a geometry with planar or spatial features. This is usually defined based on consideration of architectural functions, such as space division, people-flow, light, and ventilation requirements. For example, it can be a wall with openings representing doors and windows, a hemispherical shell with holes on the top representing skylights, or a trimmed solid box representing an entire building. It should be noted that, during the optimization process, only materials in the design domain can be removed, retained, or reintroduced. This means that the optimal topology can only be made up of material within the design domain. In this

way, the design domain, on the one hand, provides space for the morphology to change but, on the other hand, constrains the scope of that variation. Therefore, this essential relationship between the design domain and the resulting optimal topology makes the design domain one of the most dominant parameters that influences the optimization results of original structures.

The second consideration is the different loading scenarios on original structures. The purpose of topology optimization is to generate structural configuration with best mechanical performance under the external loads. The loads acting on buildings include gravity, live-, wind-, and snow-load, as well as concentrated (point) forces applied at certain positions to represent specific objects. With a small change in external loads, major variation of optimal topology can occur, since it is the mechanical response of the structure under these loads that determines the evolutionary direction of the optimization process.

Boundary conditions are the third parameter to consider. For buildings, boundary conditions usually include pin-supports, roller-supports, or fixed-supports. These supports can be present at specific discrete points, applied continuously along lines or curves, or even distributed across an entire surface. The boundary condition specifies the positions where the structure transfers its external loads to the foundations. Therefore, slight variations in boundary conditions also introduce significant changes in the optimization results.

Material properties also need to be carefully defined, and it is often the case that there will be more than one type of material being used within one architectural design of buildings or any specific structural members. For example, many high-rise buildings are constructed from steel beams, columns and decks, with a reinforced concrete slab poured on the deck in-situ to make a composite floor system. Specifying different material properties in different areas of a building can have a significant effect on its structural response, and hence its optimal topology. However, architectural morphology generation is usually carried out at an early stage of architectural design, at which point it is usually considered acceptable for only one material to be used for topology optimization. It is also a common assumption during early stage design that only linear elastic deformation would occur within the structure. In this case, the optimal topology for one material is also the optimal topology for another material. Therefore, for the purpose of this paper, the difference in the topology optimization results caused by the variation of materials can be assumed to be negligible.

Besides the optimization initialization parameters outlined above, the formulation of the topology optimization itself also involves the defining of parameters that have an impact on the results. Generally, the formulation of a topology optimization problem requires the definition of objective functions and constraint functions. The objective functions use objective index or performance index as dependent variable and input parameters as independent variable, and objective index or performance index is what researchers want to maximize or minimize, for example, maximizing overall structure stiffness. Besides, researchers

can use the constraint functions to apply specific geometric or mechanical constraint to optimized structures, such as minimum/maximum feature size [19, 20] and symmetry and pattern repetition [21]. These two kinds of functions are usually determined based on consideration of mechanical properties or geometric features of the design of original structure and can involve measures of deformation, stress, stability, material volume, etc. The influential parameters introduced above are classified into two categories as summarized in Table 1.

2.2. Morphology Generation Procedure. In this paper, the authors employ topology optimization as the method for generating candidates for architectural morphology designs, by changing the influential parameters listed in Table 1. The adopted procedure is shown in Figure 1, and a detailed explanation is given as follows:

- (1) Define the formulation parameters (objective- and constraint functions)
- (2) Define the initialization parameters (design domain, load, boundary conditions, and material properties)
- (3) Use the parameters defined in Steps (1) and (2) to solve the topology optimization subproblem
- (4) Evaluate the topology produced by Step (3). If satisfied, output the result; if not, return to Step (1) or (2) and modify the parameters accordingly

There are various options available to solve the topology optimization problem in Step (3). One approach is to implement source code, such as those introduced in Wei et al. [22]. The code solves minimum compliance problem, which maximizes overall structure stiffness under limited material usage. However, most users will choose to apply off-the-shelf software that provides the topology optimization functions, for example, one of the many plugins for Rhino/Grasshopper, such as TopOpt [23] and Ameba [24]. This kind of software is widely used in parametric model generation of optimized architecture. Additionally, some commercial Finite Element software packages have built-in Topology Optimization functionality, such as Altair Inspire [25] and OptiStruct [26]. This kind of software is adopted in vast range of engineering product design.

This study uses the three analysis techniques in the multiattribute decision-making method to build an evaluation analysis model to evaluate the obtained topological results. Firstly, the fuzzy Delphi method (FDM) is used to extract the design elements, which can have an important influence on the satisfaction of obtained topological results. This technology has been widely used in planning and evaluation research in related fields such as regional governance, community management, and landscape architecture [27, 28]. Compared with the traditional Delphi, the advantages of introducing the fuzzy technique include (i) reducing the number of surveys, (ii) the opinions of experts being expressed completely, (iii) the expert being relatively rational and in line with demand, and (iv) being economical in terms of time and cost. Secondly, regarding the

TABLE 1: Influential parameters for architectural morphology generation.

Influential parameters	Parameters for initialization of optimization problem	Design domain Load scenario Boundary condition Material property
	Parameters for formulation of optimization problem	Objective function Constraint function

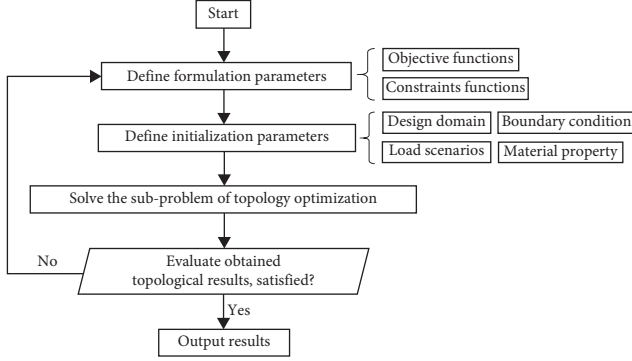

FIGURE 1: Morphology generation procedure.

clarification of the priority of the dimension layer, this study will apply the analytic hierarchy process (AHP) that has been widely used in related research to train the relative weight between the evaluation elements (dimension/elements). The application of this analysis technique relies on expert domain knowledge, through pairwise comparison between elements, to clarify stakeholders' considerations of the relative importance of elements. Finally, The Technique for Order of Preference by Similarity to Ideal Solution (TOPSIS) is used to sort and select the performance of several obtained topological results. This analysis technique was proposed by Hwang and Yoon [29]. The basic idea is that the closer to the positive ideal solution, the better; on the contrary, the farther away from the negative ideal solution, the better.

The FDM used in this study is to integrate expert opinions by means of "double triangular fuzzy number" [30], and to test whether expert cognition shows a consistent convergence effect by "grey zone verification method." The concrete steps are as follows:

Step (F1): The "most conservative cognitive value" and the "most optimistic cognitive value" given by all experts to each element i are statistically analyzed, and the extreme value outside "2 times standard deviation" is eliminated. Then, the minimum value C_L^i , geometric mean value C_M^i , maximum value C_U^i in the remaining "most conservative cognitive value," and the minimum value O_L^i , geometric mean value O_M^i and maximum value O_U^i in the "most optimistic cognitive value" are calculated, respectively.

Step (F2): Based on the calculation results of Step (F1), the three-angle fuzzy number $C^i = (C_L^i, C_M^i, C_U^i)$ of the "most conservative cognition" and the three-angle fuzzy number $O^i = (O_L^i, O_M^i, O_U^i)$ of the "most optimistic cognition" for each evaluation element i are calculated, respectively.

Step (F3): Testing whether the experts' opinions present a consistent convergence effect can be judged by the following ways.

- (1) If there is no overlap between the two triangular fuzzy numbers, i.e., $C_U^i \leq O_L^i$, it will be indicated that the opinion interval value of each expert has a consensus section, and the opinion tends to be within this consensus section, so the "consensus value" G_U^i of this evaluation element i can be calculated by

$$G_U^i = \frac{C_M^i + O_M^i}{2}. \quad (1)$$

- (2) If there is an overlap between the two triangular fuzzy numbers, i.e., $C_U^i > O_L^i$, and the grey area $Z^i = C_U^i - O_L^i$ of the fuzzy relationship is smaller than the range $M^i = O_M^i - C_M^i$ between the "geometric mean of optimistic cognition" and "geometric mean of conservative cognition" for the evaluation criterion by the expert, it means that although there is no consensus section for each expert's opinion interval value, the two experts who gave extreme opinions (the most conservative expert of the optimistic cognition and the optimistic expert of the conservative cognition) do not differ too much from other experts in opinions and led to divergent opinions. Then, the "consensus value" G_U^i of this evaluation element i can be calculated by

$$G_M^i = \frac{O_M^i \times C_U^i - O_L^i \times C_M^i}{(O_M^i - O_L^i) + (C_U^i - C_M^i)}. \quad (2)$$

- (3) If $C_U^i > O_L^i$ and $Z^i = C_U^i - O_L^i$ is larger than $M^i = O_M^i - C_M^i$, it means that there is no consensus section for each expert's opinion interval value, and the two experts who gave extreme opinions (the most conservative expert of the optimistic cognition and the optimistic expert of the conservative cognition) differ too much from other experts in opinions and led to divergent opinions. Therefore, it is necessary to carry out a new round of questionnaires and repeat steps one to three until all the evaluation items have reached convergence, and the corresponding "consensus value" is obtained.

The AHP is a comprehensive framework that is suitable for situations when people make multiobjective, multicriterion, and multisector decisions with or without certainty for any number of alternatives. The technique procedures to gain the weights are described as follows:

Step (A1): Compare the relative importance of factors pairwise and obtain an $n \times n$ pairwise comparison matrix, where n means the number of element.

Step (A2): Check the logical judgment consistency using the consistency index (C.I.) and consistency ratio (C.R.). The C.I. value is defined as $C.I. = (\lambda_{\max} - n) / (n - 1)$, where λ_{\max} is the largest eigenvalue of the pairwise comparison matrix. The C.R. value is defined as $C.R. = C.I./R.I.$, where R.I. is a random index decided by the value of n . (The R.I. values corresponding to $n = 1, 2, \dots, 10$ are 0, 0, 0.58, 0.9, 1.12, 1.24, 1.32, 1.41, 1.45, and 1.49, respectively.) In general, the values of C.I. and C.R. should be less than 0.1 or reasonably consistent.

Step (A3): Use the normalized eigenvector of the largest eigenvalue λ_{\max} as the factor weights.

TOPSIS (technique for order preference by similarity to an ideal solution) method is presented in Chen and Hwang [31], with reference to Hwang and Yoon [29]. The TOPSIS procedure consists of the following steps.

Step (T1): Calculate the normalized decision matrix. The normalized value n_{ij} is calculated by

$$n_{ij} = \frac{x_{ij}}{\sqrt{\sum_{i=1}^m x_{ij}^2}}, \quad i = 1, \dots, m, \quad j = 1, \dots, n. \quad (3)$$

Step (T2): Calculate the weighted normalized decision matrix. The weighted normalized value v_{ij} is calculated as

$$v_{ij} = w_j n_{ij}, \quad i = 1, \dots, m, \quad j = 1, \dots, n. \quad (4)$$

where w_j is the weight of the i -th attribute, and $\sum_{i=1}^m w_j = 1$.

Step (T3): Determine the positive ideal and negative ideal solution.

$$\begin{aligned} A^+ &= \{v_1^+, \dots, v_n^+\} \\ &= \left\{ \left(\frac{\max_j v_{ij}}{i \in I} \right), \left(\frac{\min_j v_{ij}}{i \in J} \right) \right\}, \\ A^- &= \{v_1^-, \dots, v_n^-\} \\ &= \left\{ \left(\frac{\min_j v_{ij}}{i \in I} \right), \left(\frac{\max_j v_{ij}}{i \in J} \right) \right\}. \end{aligned} \quad (5)$$

The intention of using (5) is to calculate the maximum and minimum score of each criterion in each alternative.

Step (T4): Calculate the separation from the positive ideal solution, given as

$$d_i^+ = \left\{ \sum_{j=1}^n (v_{ij} - v_j^+)^2 \right\}^{1/2}, \quad i = 1, \dots, m. \quad (6)$$

Similarly, the separation from the negative ideal solution is given as

$$d_i^- = \left\{ \sum_{j=1}^n (v_{ij} - v_j^-)^2 \right\}^{1/2}, \quad i = 1, \dots, m. \quad (7)$$

Step (T5): Calculate the relative closeness to the ideal solution. The relative closeness of the alternative A_i with respect to A^+ is defined as

$$R_i = \frac{d_i^-}{(d_i^+ + d_i^-)}, \quad i = 1, \dots, m. \quad (8)$$

Since $d_i^- \geq 0$ and $d_i^+ \geq 0$ then, clearly, $R_i \in [0, 1]$.

Step (T6): According to the calculation of R_i value, the performance ranking of alternative cases can be obtained, and the higher the R_i value is, the higher the ranking order is.

3. Classification of Architectural Application Scenarios

In order to carry out the above procedure, it is important to know the allowable range within which each parameter (design domain, load scenario, and boundary condition) for such architectural application scenarios can vary. Since the range will depend to a large extent on the specific problem being investigated, it is necessary to divide the potential problems into subclasses and then address each in turn to determine suitable ranges.

3.1. Essential Architectural Application Scenarios. The two criteria for classification of problem scenarios adopted by the authors are the scenarios' force mechanisms and geometrical features, and typical scenarios are summarized in Table 2. For those scenarios, where the force mechanisms are constrained much within two dimensions, i.e., the forces are generally flowing within one plane, they are classified as surface application scenarios. Shells are included in this group, because the influence of their third dimension (thickness) is negligible to the other two dimensions, and under external load, the force within the shell can be viewed as flowing within its mid-surface. Scenarios that transfer load in three dimensions are classified as volumetric applications. They include joints (where forces do not generally lie in a single plane), multifloor buildings, and spatial structures. Of course, there are other ways of categorizing architectural application scenarios, and there are other scenarios that are not explicitly considered within this paper. However, the classification adopted here is sufficient to assess the likely limits for the modelling parameters across a suitably wide range of architectural scenarios.

3.2. Optimization Parameters. Based on the classification above, the ranges of influential parameters for morphology generation can be investigated. Since morphology generation usually takes place during early design stage, the parameters that formulate the topology optimization problem

TABLE 2: Essential architectural applications scenarios.

Surface application scenarios	Beams and arches
	Walls
Volumetric application scenarios	Shell structures
	Joints
	Multi-storey buildings
	Spatial structures

(objective functions and constraints functions) can remain unchanged. Additionally, it is usually structural stiffness and material volume that attract most attention in design optimization; therefore, it is reasonable to adopt the structural stiffness and material volume as objective and constraint, respectively.

In the following study, only the parameters for initialization of the optimization problem (the design domain, load and boundary condition) are investigated. The material property is omitted here, because, during the conceptual stage, it is sensible to assign only one type of material to the entire design domain, as discussed above. However, the effects of different combinations of materials on the topological results should still be borne in mind [32].





3.2.1. Parameters for Beams/Arches. Beams or arches can be characterized by their length to height ratio. They usually have a span around ten times larger than their height, which makes bending moments the dominant action. The common optimization parameters for beams/arches are summarized in Table 3, but of course many other parameters exist, and the approach proposed in this paper would be equally applicable to their investigation.

In terms of its design domain, it can be a rectangle, with or without a tapered or curved upper edge. Common load scenarios include distributed load acting along the top-, middle-, or bottom edge, or concentrated point load acting at some point along the span. Supports might be pinned, rolled, or (rotationally) fixed, generally positioned at the two ends of the beam/arch. The main difference between a beam and an arch is whether or not the supports resist the horizontal movement, with an arch able to thrust horizontally into the supports, and a beam not. Additionally, there may be several supports along the length of a continuous beam.

3.2.2. Parameters for Walls. The common optimization parameters for wall are summarized in Table 4, where the span-height ratio of a wall is much closer to unity. A wall might be supported at its two lower corners, or fully supported along its lower edge. Compressive loads usually dominate the design of wall, and gravity load is often the main source. However, in high-rise buildings, a wall's height can be significant compared to its span, and the lateral load generated by wind pressure can be the dominant scenario.

3.2.3. Parameters for Shells. The common optimization parameters for shells are summarized in Table 5, where shells have a span of tens or hundreds of their thickness. The shell can be hemispherical, cylindrical, saddle-shaped, or

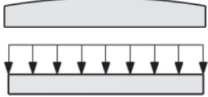
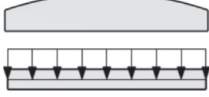
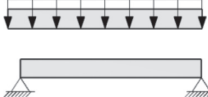
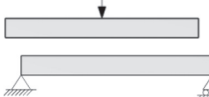
TABLE 3: Parameters for beam/arch.

Parameters	Potential varying ranges	
Design domain		
Load scenario		
Boundary condition		
		

completely freeform. The most common loads acting on shells are out-of-plane loads such as gravity or area-distributed, but they can also resist loads in a horizontal plane, be they in a single direction or twisting-loads inducing a moment. Shells are usually supported around their lower edge, either at discrete points via pinned- or (rotationally) fixed-supports or continually around the edge.

3.2.4. Parameters for Joints. Joints usually occur at the intersection of several different components (usually beams), and their common optimization parameters are summarized in Table 6. The design domain for a joint can be a polygonal geometry, where the incoming members lie in a plane, or a solid sphere for fully 3D joints. The loads acting at joint are the forces transferred in from the surrounding components. During topology optimization, one of its edges or its surfaces usually is assumed totally fixed [33].

3.2.5. Parameters for Multistorey Buildings. The common optimization parameters for multistorey buildings are summarized in Table 7. Their design domain can be a regular solid geometry or a collection of several such geometries. The loads acting on them are usually gravity-based, but horizontal forces can also become dominant for high-rise buildings. Common boundary conditions include point-supports at the corners, edge-supports along the bottom edges, or full rotational restraint across their whole lower surface.

3.2.6. Parameters for Large-Scale Spatial Structures. The common optimization parameters for large-scale spatial structures are summarized in Table 8. Their design domain is similar to multistorey buildings, the difference being that the span of a spatial structure is usually much larger than its height, the exact opposite of a multistorey building. The loads and common boundary conditions are the same as those of multistorey buildings.

4. Relationship between Optimization Parameters and Topological Results

In this section, the beam/arch category is first chosen as the focus of a benchmark case-study to investigate the

TABLE 4: Parameters for walls.







Design domain			
Load scenario			
Boundary condition			

TABLE 5: Parameters for shells.



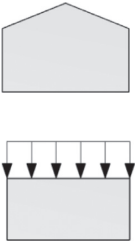
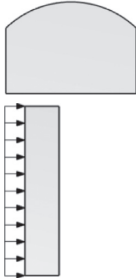







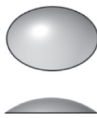

Design domain				
Load scenario				
Boundary condition				

TABLE 6: Parameters for joint structures.

Design domain	
Load scenario	
Boundary condition	

relationship between the optimization parameters and the topological results. The extension of the approach to the morphology generation of shell structures is then discussed.

The relationship is investigated by conducting a parametric study on the different input parameters and assessing their effect on the topology optimization results. As a benchmark, typical optimization parameters are first

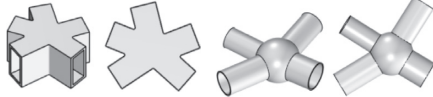
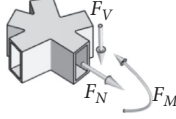
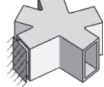
assumed, and then variations around these benchmark values are analyzed and their effect quantified.

4.1. Benchmark Example. A rectangular surface with a span of 10 m and a height of 1 m is selected as the design domain for the benchmark study. Its boundary condition is two pinned supports at the lower two corners, and it has a uniformly distributed load acting along the top edge. To ensure that the load remains unchanged during topology optimization, a very thin layer of material that directly sustains the load is kept along the top edge during the whole optimization process. Strain energy is selected herein as the objective to be minimized, as it is commonly used in optimization to reflect the global flexibility of structure [7]. Steel is adopted as the material for the whole structure, and the material volume is constrained to be 30% of the material volume in the initial design.

The topologies at three different optimization iterations are shown in Table 9. The form of a single long-spanning arch emerged at the very start of the solution process and is unmistakable by the 50th iteration. The hierarchical

TABLE 7: Parameters for multistorey buildings.

Design domain	
Load scenario	
Boundary condition	

TABLE 8: Parameters for large-scale spatial structures.

Design domain	
Load scenario	
Boundary condition	

branches reaching out from the main arch to the top edge gradually become more delicate as the iterations progress, and more material is removed. The resulting topology at iteration 150 explicitly symbolizes the force-paths but displays a discrete and organic geometry; thus, it can be viewed as a combination of mechanical rationality and architectural aesthetics.

4.2. *Extended Examples.* To investigate the influence of the optimization parameters on the obtained topological results, the topology optimization was run a number of times, each with different combinations of optimization parameters. The topological results were compared with the benchmark example in Table 9 to demonstrate these influences.

4.2.1. *Design Domains.* The top edge of the rectangular surface was curved in two different scales, and the topological results are shown in Table 10 (Rows 1 and 2). Comparison with the benchmark example shows that the morphologies are very similar, with the largest difference being the curvature of the arch, which adjusts to match the design domain.

TABLE 9: Topological result of typical beam/arch.

Sketch of optimization parameters	Iteration	Topological results
	50	
	100	
	150	

TABLE 10: Topological result of extended examples of beam/arch.

No.	Sketch of optimization parameters	Topological results	Notes
1			Design domain
2			Design domain
3			Load scenario
4			Load scenario
5			Load scenario
6			Boundary condition
7			Boundary condition
8			Volume constraint

4.2.2. *Load Scenarios.* The load acting along the top edge is first moved to the mid-line, then to the bottom edge, and finally changed to be a concentrated force acting at the midpoint of the top edge. The topological results are shown in Rows 3–5 of Table 10, respectively. When the load remains a uniformly distributed line load, the main structural system remains an arch, even when the line acts at a different position vertically. As the load moves downward, the secondary branches connecting to the main arch adjust automatically to transfer load from the points of application to the arch. These geometrical changes result in corresponding mechanical changes, since the forces in branches switch from compression to tension.

Concentrating the load into a point (Table 10 Row 5) converts the arch into a truss and allows the removal of material from other areas.

4.2.3. *Boundary Conditions.* Two kinds of boundary conditions are considered. One is simply supported at the left and right lower corners, and the other is clamped along the left and right edges. The corresponding optimization results are shown in Table 10 (Rows 6 and 7).

When one support of the benchmark is changed to a roller and no longer provides horizontal restraint (Table 10 Row 6), material is retained along the bottom edge, acting as a tension tie to prevent the relative displacement of the two supports. Another change is that, without the horizontal thrust

resistance of the supports, the structure represents a bowstring beam structure [34] rather than an arch. With fully fixed-supports available along the two edges (Table 10 Row 7), the obtained topology again represents a bowstring beam; however, its depth is roughly 1/5 of the span, and this can be mapped to the inflection points of its bending moment.

4.2.4. Material Volume Fraction. By varying the target volume fraction of material, different topological results are generated. Row 8 of Table 10 is obtained from a volume fraction of 50%. Comparison with the benchmark example shows little difference, but when more material is retained, most of it goes into thickening the arch.

4.2.5. Discussion. The influence of the four types of optimization parameters (design domain, load scenario, boundary condition, and material volume fraction) is investigated in this section. It can be concluded that the topological results are very sensitive to the optimization parameters, and slight changes in one parameter can result in a large difference to the obtained topology. Therefore, it is justified to demonstrate that this sensitive relationship can be used to generate a wide variety of optimal topologies, and amongst them, the best architectural design can be chosen.

5. Morphology Generation of Shells

Shells have been widely adopted as efficient solutions for covering large spaces, and the practical implementation of shells can be seen in exhibition pavilions, sports and entertainment venues, and transportation interchanges, to name a few. Famous examples include the Palazzetto Dello Sport by Pier Luigi Nervi in Rome, or Los Manantiales Restaurant by Felix Candela in Mexico [35]. However, within a fully continuous shell, there is generally some material that is not needed to transfer load to the supports, and it can therefore be removed. Topology optimization is adopted here as the approach to determine where to remove material from a shell. In this section, a truncated sphere shell is adopted for investigation, and the morphology generation results of this geometry are presented below.

5.1. Benchmark Example. We selected the stadium roof structure as a fixed functional requirement, and it is located in Guangzhou with a subtropical climate. The geometry considered here is a trimmed sphere, with a span of 60 m and a height of 10 m, as shown in Figure 2. It is pin-supported at 16 equally spaced points around the bottom edge. As in Section 4, steel is adopted as the material, strain energy is used as the objective function, and the material fraction target is 30% of the initial design domain. Only a uniformly distributed surface load is considered acting vertically. The load is first applied on an identical shell that has an extremely high stiffness. The load is then transferred to the topology optimization model by defining a tie-constraint between these two geometries. Since the load, geometry, and boundary conditions are all symmetric, a 1/4

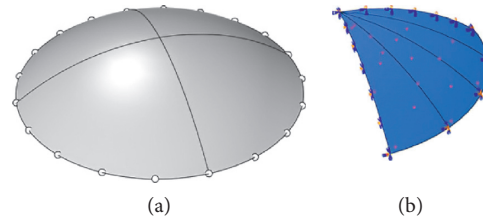

FIGURE 2: Optimization parameters of spherical shell. (a) Whole structure. (b) 1/4 substructure.

substructure model is adopted for the topology optimization process, whilst the full model is used for visualization by mirroring the submodel along the two planes of symmetry.

The optimization of this geometry was carried out in Abaqus/Tosca [24]. The topologies at six different iteration steps are shown in Figures 3 and 4. Only cells with a density of 0.3 or greater are displayed to improve clarity. The main structural system has started to emerge by the 40th iteration, after which the hierarchical branches between main arches and rings gradually appear and become more and more delicate.

A modification to the geometry was made by introducing several holes into the design domain (see Figure 5). The holes can be viewed as a reflection of the architectural requirements, for example, roof-lighting or ventilation functions. Optimization of this new geometry is also carried out using the same optimization parameters.

The topologies at six different optimization iterations are shown in Figures 6 and 7. The main difference between this case and the one without holes is seen near the apex, where a small ring appears instead of a fully filled circle. The main structures reaching out from the supports also change from Y- to V-shapes, and the bottom ring moves up slightly. It can be concluded that the holes in the design domain have led to obvious changes in the topological results. However, these changes appear as adaptations of the original topology and remain aesthetically acceptable, which demonstrates the applicability of the proposed methodology.

5.2. Evaluation Example. The result of structural form generation basically conforms to the engineering aesthetic law of structural rationality, but the diversified result selection is mainly for the evaluation of architects. From the perspective of the law of formal beauty, we asked experts in the industry to discuss the shape of the shell structure and summarize 5 important evaluation factors. Based on it, the study uses a 9-point Likert scale for the expert questionnaire, which was sent to 37 experts. All of the experts interviewed had master's degrees or above, among which 12 had received doctoral degrees in architecture and related fields, and a total of 28 had more than 5 years of work experience of architectural design. A total of 32 valid questionnaires were finally collected, and the data was analyzed by the AHP method. The relative significance degrees among the five evaluation elements are shown in Table 11, and the opinions of the experts passed the test of consistency ($CI = 0.087$; $CR = 0.078$).

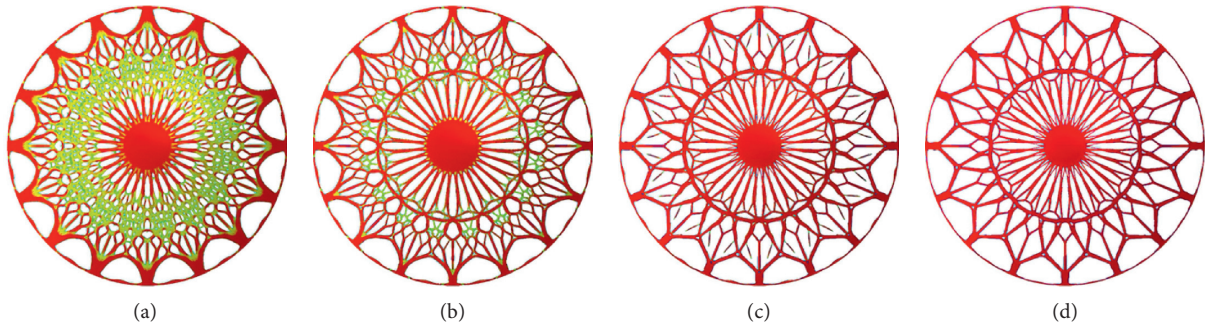

FIGURE 3: Optimization results of a spherical shell (project view). (a) 40th iteration. (b) 60th iteration. (c) 80th iteration. (d) 95th iteration.

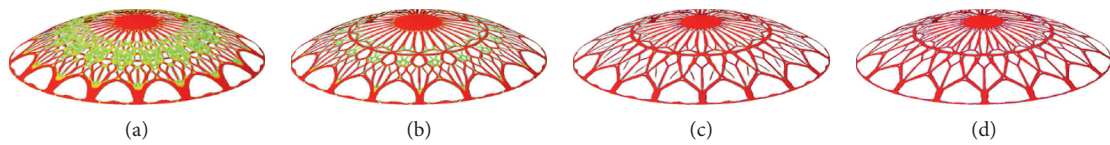

FIGURE 4: Optimization results of a spherical shell (isometric view). (a) 40th iteration. (b) 60th iteration. (c) 80th iteration. (d) 95th iteration.

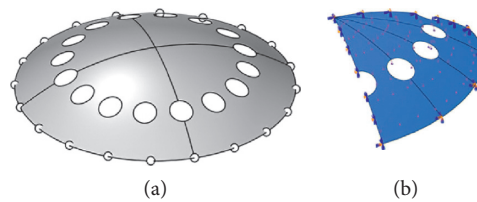

FIGURE 5: Optimization parameters of spherical shell. (a) Whole structure. (b) 1/4 substructure.

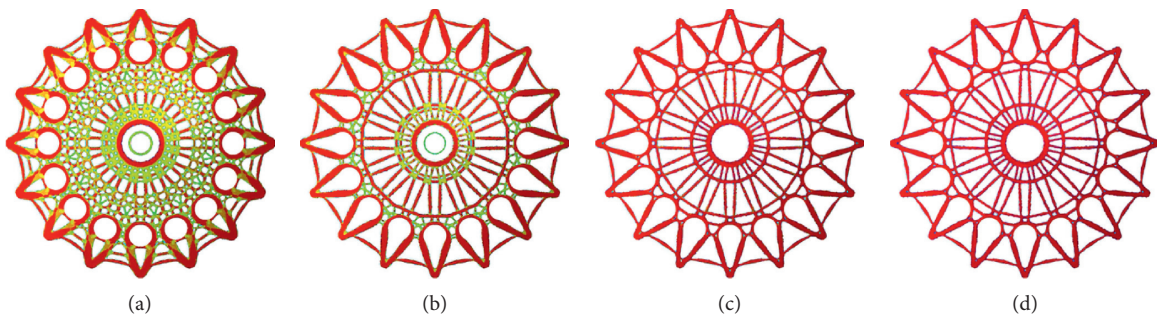

FIGURE 6: Optimization results of a spherical shell with predefined holes (project view). (a) 40th iteration. (b) 60th iteration. (c) 80th iteration. (d) 95th iteration.

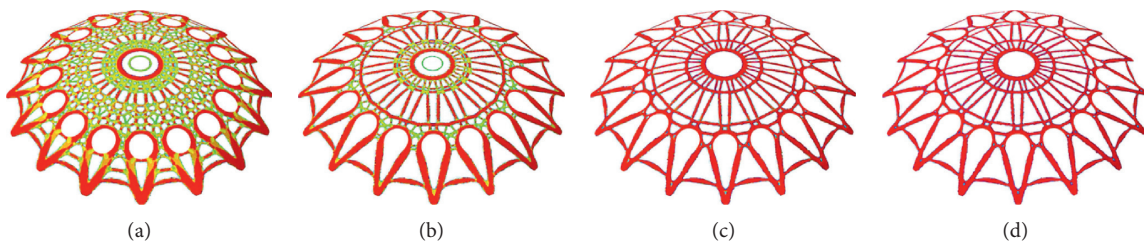
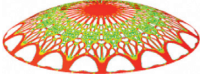
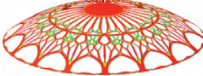
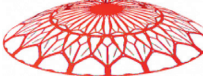
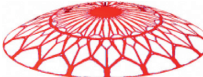
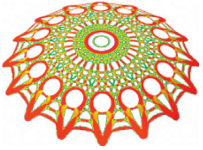





FIGURE 7: Optimization results of a spherical shell with predefined holes (isometric view). (a) 40th iteration. (b) 60th iteration. (c) 80th iteration. (d) 95th iteration.

TABLE 11: Description of evaluation methods and relative weight.

Evaluation factors	Descriptions	Weights
Rhythmicity (E_1)	The constituent elements of the form offers an arrangement of structured repetition and alternation, bringing a visual aesthetics of continuity	0.131
Proportionality (E_2)	The size and quantity of each constituent element of the form meet a certain scale, conveying a sense of beauty	0.398
Balance (E_3)	The constituent elements of the form maintain a visual balance of forces	0.118
Layering (E_4)	Whether the constituent elements of the form convey a sense of layering, and show the varying characteristics of different layer	0.071
Concordance (E_5)	Whether the constituent elements of the form are in harmony with each other, creating a relatively coherent sense of form	0.282

TABLE 12: Performance ranking of evaluated cases.

No.	Evaluation examples	Evaluation factors					d_i^+	d_i^-	R_i	Rank
		E_1	E_2	E_3	E_4	E_5				
C1		0.236	0.190	0.201	0.238	0.332	0.154	0.036	0.188	8
C2		0.368	0.301	0.362	0.508	0.382	0.102	0.074	0.420	4
C3		0.350	0.328	0.315	0.414	0.396	0.092	0.080	0.465	3
C4		0.426	0.297	0.375	0.310	0.350	0.105	0.067	0.391	5
C5		0.512	0.486	0.418	0.293	0.452	0.029	0.144	0.833	2
C6		0.299	0.547	0.400	0.429	0.415	0.030	0.156	0.837	1
C7		0.289	0.256	0.358	0.285	0.216	0.138	0.033	0.195	7
C8		0.266	0.278	0.354	0.258	0.205	0.133	0.040	0.230	6

Then, with the eight shell structure forms obtained by topological optimization in the previous part of this paper as evaluation cases, the study applies TOPSIS method to evaluate the performance of each case and rank the cases based on experts' aesthetic experience. The performance evaluation questionnaire was designed on a scale of 0–10 and administered to a group of experts who had previously completed the AHP questionnaire. A total of 35 valid questionnaires were collected, and the results of the performance evaluation analysis are shown in Table 12.

According to the performance evaluation analysis, case C6 is the best solution among the eight shell structure forms, while the rest are C5, C3, C2, and C4 in order, and the worst solution in performance is C1. The study applies the AHP-TOPSIS model to integrate the subjective opinions of experts. After obtaining several structural forms that have structural rationality and conform to aesthetic laws, the study constructs an evaluation system to clarify the performance ranking of different structural forms. In summary, this study integrates the topology optimization tool kit and parametric design

theory with a MADM model to construct a process model that goes from the generation to the performance evaluation of structural forms of architecture. With the application of topology optimization and parametric design concepts, architects have access to a diverse selection of solutions. These solutions are consistent with structural rationality and a certain degree of engineering aesthetics. However, in real situations, the evaluation and ranking of structural design solutions generally requires a clear evaluation objective or perspective based on group decisions of stakeholders. The case evaluation in this section is conducted in the context of structural form aesthetics. In short, the evaluation and ranking of each design case is done based on the aesthetics of the form as the evaluation objective. However, a more theoretical and applied value is proposed in this study, which includes topology optimization, parametric modelling, and multiattribute decision-making process of building structure design. It covers the form of generation to evaluation and selection of structural design solutions.

6. Conclusions

In this study, by integrating topology optimization toolsets and parametric design theory, combined with multiattribute decision-making analysis, a method of morphology generation for architectural design is proposed. The design method could efficiently obtain several architectural structural morphologies with both structural rationality and aesthetic rules and complete the evaluation and selection of several alternatives through multiattribute decision-making. At the level of morphology generation, based on the load-bearing mechanism and geometrical features, the essential architectural application scenarios are classified into two groups in this study, namely, surface application scenarios (including beam/arch, wall, and shell) and volumetric application scenarios (including joints, multistorey buildings, and spatial structures). On this basis, the possible variation range of the optimization parameters (design domain, load scenario, and boundary condition) for such architectural application scenarios is determined. This will provide architects with direct guidance when applying topology optimization toolsets and parametric design theories to architectural morphology generation. On the other hand, by analyzing the relationship between the optimization parameters and the topological results, with the beam/arch application scenario as an example, it is proved that this sensitive relationship can be used to generate a cluster of alternatives for architectural morphology design. In addition, the morphology generation of shells is investigated through two different design domains, one with and one without holes. The organic, discrete, and mechanically rational topological results demonstrate the applicability and efficiency of the proposed methodology.

In order to clarify the whole process from architectural morphology generation to scheme evaluation and selection by the design method, the FAHP-TOPSIS model is applied to complete the performance ranking and selection of evaluation cases by taking 8 topological methodology generation results as evaluation cases, as well as the principle of

architectural form, as the basic evaluation criteria in this study. In the future, scholars and architects can apply this design method in related studies, formulate corresponding evaluation objectives in specific realistic situations, and also complete the performance evaluation and ranking of several topological results by relying on expert experience. Even when the improvement of the design scheme after the evaluation ranking is discussed, DANP technology can be used to replace AHP technology in the future multiattribute decision-making model, so as to clarify the interaction relationship between the criteria under the proposed evaluation objectives, which is helpful in exploring the improvement strategy of different schemes from a systematic and dynamic perspective. In the follow-up study, a nonadditive performance analysis technique may be used tentatively instead of the TOPSIS technique used in this study. Therefore, the TOPSIS method used in this study to assess performance levels in the case studies is an additive method. However, circumstances in practice may often be nonadditive, and thus follow-up research may use nonadditive methods to assess performance more closely approximating actual circumstances.

Data Availability

The data used to support the findings of this study are included in the article.

Conflicts of Interest

The authors declare no conflicts of interest.

Acknowledgments

The authors are grateful to all the medical staff and designers who took part in this study. The authors would like to thank Lei Xiong, the research assistant, for all the hard work and effort put in to make the questionnaire survey a success. The authors are also immeasurably grateful to the alumni association of the Environmental Art Design, School of Architecture and Applied Art, Guangzhou Academy of Fine Arts, for the support during the research. This study was funded by the art projects supported by National Social Science Foundation (project number: 18BG08). This work was also supported by the Guangdong Philosophy and Social Sciences “Thirteenth Five-Year” Plan 2020 Annual Disciplinary Co-construction Project “Multi-attribute Decision Analysis and Activation Strategy Research on Cultural Heritage Blocks in Guangfu Region Based on AOD Concept” (project number: GD20XYS41).

References

- [1] I. Dobritsyna, “Discreteness in the architecture of the 21st century,” in *Proceedings of the 3rd International Conference on Art Studies: Science, Experience, Education (ICASSEE 2019)*, pp. 34–38, Moscow, Russia, November 2019.
- [2] B. Kolarevic, *Architecture in the Digital Age: Design and Manufacturing*, Spon Press, New York, NY, USA, 2003.

- [3] D. Lauriola, "Combining efficiency and aesthetics through the integration of structural topology optimization in architecture," M. S. thesis, Technical University of Cartagena, Cartagena, Spain, 2017.
- [4] J.-H. Zhu, W.-H. Zhang, and L. Xia, "Topology optimization in aircraft and aerospace structures design," *Archives of Computational Methods in Engineering*, vol. 23, no. 4, pp. 595–622, 2016.
- [5] M. P. Bendsoe, "Optimal shape design as a material distribution problem," *Structural Optimization*, vol. 1, no. 4, pp. 193–202, 1989.
- [6] G. Rozvany, "The SIMP method in topology optimization—theoretical background, advantages and new applications," in *Proceedings of the 8th Symposium on Multidisciplinary Analysis and Optimization*, Long Beach, CA, USA, September 2000.
- [7] O. Sigmund, "A 99 line topology optimization code written in matlab," *Structural and Multidisciplinary Optimization*, vol. 21, no. 2, pp. 120–127, 2001.
- [8] Y. M. Xie and G. P. Steven, "A simple evolutionary procedure for structural optimization," *Computers & Structures*, vol. 49, no. 5, pp. 885–896, 1993.
- [9] X. Huang and Y. M. Xie, "Convergent and mesh-independent solutions for the bi-directional evolutionary structural optimization method," *Finite Elements in Analysis and Design*, vol. 43, no. 14, pp. 1039–1049, 2007.
- [10] J. A. Sethian and A. Wiegmann, "Structural boundary design via level set and immersed interface methods," *Journal of Computational Physics*, vol. 163, no. 2, pp. 489–528, 2000.
- [11] M. Y. Wang, X. Wang, and D. Guo, "A level set method for structural topology optimization," *Computational Methods in Applied Mathematics*, vol. 192, no. 7, pp. 227–246, 2003.
- [12] G. Allaire, F. Jouve, and A.-M. Toader, "Structural optimization using sensitivity analysis and a level-set method," *Journal of Computational Physics*, vol. 194, no. 1, pp. 363–393, 2004.
- [13] X. Guo, "Doing topology optimization explicitly and geometrically—a new moving morphable components based framework," *Journal of Applied Mechanics*, vol. 81, no. 8, Article ID 081009, 2014.
- [14] W. Zhang, J. Yuan, J. Zhang, and X. Guo, "A new topology optimization approach based on moving morphable components (MMC) and the ersatz material model," *Structural and Multidisciplinary Optimization*, vol. 53, no. 6, pp. 1243–1260, 2016.
- [15] Y. Sui and X. Peng, "The ICM method with objective function transformed by variable discrete condition for continuum structure," *Acta Mechanica Sinica*, vol. 22, no. 1, pp. 68–75, 2006.
- [16] L. L. Beghini, A. Beghini, N. Katz, W. F. Baker, and G. H. Paulino, "Connecting architecture and engineering through structural topology optimization," *Engineering Structures*, vol. 59, pp. 716–726, 2014.
- [17] H. Ohmori, "Computational m," *International Journal of Space Structures*, vol. 26, no. 3, pp. 269–276, 2011.
- [18] X. Peng, "Structural topology optimization method for morphogenesis of dendriforms," *Open Journal of Civil Engineering*, vol. 6, no. 4, pp. 526–536, 2016.
- [19] O. Sigmund, "Morphology-based black and white filters for topology optimization," *Structural and Multidisciplinary Optimization*, vol. 33, no. 4–5, pp. 401–424, 2007.
- [20] J. K. Guest, "Imposing maximum length scale in topology optimization," *Structural and Multidisciplinary Optimization*, vol. 37, no. 5, pp. 463–473, 2009.
- [21] Y. Liu, Z. Li, P. Wei, and W. Wang, "Parameterized level-set based topology optimization method considering symmetry and pattern repetition constraints," *Computer Methods in Applied Mechanics and Engineering*, vol. 340, pp. 1079–1101, 2018.
- [22] P. Wei, Z. Li, X. Li, and M. Y. Wang, "An 88-line MATLAB code for the parameterized level set method based topology optimization using radial basis functions," *Structural and Multidisciplinary Optimization*, vol. 58, no. 2, pp. 831–849, 2018.
- [23] Food4Rhino, Topopt [Online]. Available; Accessed on, 2021.
- [24] Food4Rhino, Ameba [Online]. Available; Accessed on, 2021.
- [25] CAD Software Direct, Cad & 3D sales [Online]. Available; Accessed on, 2021.
- [26] Altair, Optimization-enabled structural analysis [Online]. Available; Accessed on, 2021.
- [27] Y. Wang and G.-T. Yeo, "Intermodal route selection for cargo transportation from Korea to central Asia by adopting fuzzy Delphi and fuzzy ELECTRE I methods," *Maritime Policy & Management*, vol. 45, no. 1, pp. 3–18, 2018.
- [28] V. Assumma, M. Bottero, and R. Monaco, "Landscape economic attractiveness: an integrated methodology for exploring the rural landscapes in Piedmont (Italy)," *Land*, vol. 8, no. 7, p. 105, 2019.
- [29] C. L. Hwang and K. Yoon, *Methods for Multiple Attribute Decision Making*, Springer, Berlin, Germany, 1981.
- [30] T. B. Jeng, *Fuzzy assessment model for maturity of software organization in improving its staff's capability*, Ph.D. dissertation, National Taiwan University of Science and Technology, Taipei, Taiwan, 2001.
- [31] S. J. Chen and C. L. Hwang, *Fuzzy Multiple Attribute Decision Making: Methods and Applications*, Springer-Verlag, Berlin, Germany, 1992.
- [32] K. Tajs-Zielińska and B. Bochenek, "Topology optimization—engineering contribution to architectural design," *IOP Conference Series Materials Science and Engineering*, vol. 23, no. 4, Article ID 082057, 2017.
- [33] H. Seifi, A. Rezaee Javan, S. Xu, Y. Zhao, and Y. M. Xie, "Design optimization and additive manufacturing of nodes in gridshell structures," *Engineering Structures*, vol. 160, pp. 161–170, 2018.
- [34] M. Saitoh and A. Okada, "The role of string in hybrid string structure," *Engineering Structures*, vol. 21, no. 8, pp. 756–769, 1999.
- [35] S. Adriaenssens, P. Block, D. Veenendaal, and C. Williams, *Shell Structures for Architecture: Form Finding and Optimization*, Routledge, New York, NY, USA, 2014.