

Research Article

Humanized Management of College Students Based on Machine Perspective and Intelligent Monitoring System

Jianjun Huang 

Shaoxing University Yuanpei College, Shaoxing, Zhejiang Province 312000, China

Correspondence should be addressed to Jianjun Huang; huangjj@usx.edu.cn

Received 17 June 2022; Revised 17 July 2022; Accepted 18 August 2022; Published 6 September 2022

Academic Editor: Qiangyi Li

Copyright © 2022 Jianjun Huang. This is an open access article distributed under the Creative Commons Attribution License, which permits unrestricted use, distribution, and reproduction in any medium, provided the original work is properly cited.

In order to improve the effect of humanized management of college students, this article builds a humanized management system for college students based on the machine perspective and intelligent monitoring system, studies its hardware and software systems, and introduces the basic principle of evanescent mode resonators. Moreover, the formulas of the resonant frequency and the unloaded Q value of the resonator are deduced by the equivalent circuit of the evanescent mode resonator, and the variation curve of the unloaded Q value and the resonant frequency of the actual resonator is obtained by HFSS simulation. In addition, this article constructs a humanized management model for college students based on the machine perspective and intelligent monitoring system. The experimental research results show that the intelligent monitoring system based on the machine perspective proposed in this article has good effects and can effectively improve the quality of humanized management of college students.

1. Introduction

The management of college students must be based on the human characteristics of college students and has a comprehensive and objective understanding of them. In the stages of university study and life, their ideological concepts and behaviors must undergo varying degrees of change. This transformation reflects the constant shaping of their humanity, which is manifested through values, character, attitudes, needs, and more. Therefore, it is necessary to distinguish and recognize common factors such as values and needs of college students, as well as personality factors such as character and attitude. This is the process of understanding their humanity [1]. The management of college students should promote and guide the positive play of their human nature, and restrain and correct the play of their negative factors of human nature. Generally speaking, human nature is imperfect. There are both good and evil, both rational and irrational, both self-interest and altruistic. In the process of student management, we must not only promote and guide the positive aspects of human nature, such as cultivating professional interests, increase curiosity,

and study spirit [2], but also suppress and correct the negative factors of human nature, such as preventing cheating and academic misconduct. The two are two sides of the same question and should be placed in equal importance. Finally, the ultimate goal of the management of college students is the comprehensive development of college students, this goal and humanized management go hand in hand and complement each other. The all-round development of college students is an inevitable requirement of the development of the times. At the same time, it is also an objective requirement for the comprehensive development of individual characteristics and needs [3] at the individual level. College students have differences in family background, social experience, age, etc., which make them different in perception, attitude, personality, temperament, ability, values, etc., so management must be based on these differences. Respect the differences of personality, and fully tap the shining points of each individual personality. This is the basic requirement of individualized management of college students at the individual level [4]. Therefore, in the management process, it is necessary to fully adapt to local, time, and individual conditions, and avoid one-size-fits-all

management. At the group level, it should be seen that there are conflicts, contradictions, and frictions between personalities. Therefore, attention should be paid to the orderly coordination between personalities, so as to achieve "seeking common ground while reserving differences, and harmony without differences" [5]. To do this, first, it is necessary to set a diversified evaluation standard, so that the advantages of each student can be fully recognized, and second, to properly handle the relationship between teachers and students. Teachers should discover the shining points of individual students' personality, and provide support and encouragement to further develop these characteristics. In the relationship between students, we should pay attention to the conflicts and frictions caused by their differences [6]. For example, due to family background, some students may have different or even opposing understandings in values and consumption views, which should be paid attention to and eliminated in a timely manner. At the organizational level, it is necessary to give full play to the guiding role of the organization and advocate the full play of good personality. The guiding role can be embodied through student activities. Effective organization of student activities is one of the important contents of student management. Different activities reflect different orientations. Therefore, the content and forms of student activities can be enriched and varied, so as to meet students' needs through activities and develop students' interests. The guiding role can be played well [7]. In this process, we should focus on positive guidance, followed by negative punishment, and gradually correct negative and wrong personality tendencies. Personalized management requires adjustment of management objectives, tasks, methods, and means according to the differences in management objects. For example, for freshmen, it is necessary to focus on cultivating their adaptability, so that they can adapt to the study life of the university as soon as possible, and then purposefully cultivate their learning ability and improve their basic professional knowledge and ability [8]. For senior students, emphasis is placed on cultivating students' practical ability, so that students can get exercise in social practice. The management objectives and tasks of each stage are different, and the management methods are also different. Only in this way can students gradually tap their potential and give full play to their strengths according to the differences in their learning stages [9].

A system is a norm for human behavior, which is reflected through a series of norms, rules, and principles. Institutions provide people with standards and norms of behavior. As the saying goes: "There are no rules, no square circle," the organization can put forward clear requirements and norms for the management through rules and regulations, in order to improve the effect of management. The system is reflected through detailed methods and principles. Institutionalized management is a necessary means for colleges and universities to manage college students, which is reflected in: the humanized management of college students depends on scientific institutionalized management [10]. College students are still in the stage of unsound physical and mental development, and they need systems to regulate their behavior. As

a norm for human behavior, the system can effectively express the basic requirements of the school organization in regulating behavior. The system reflects the high degree of constraints and norms on people, and on the other hand, it also reflects the full trust and respect for people [11]. Therefore, a reasonable system design must be based on human nature and fully consider the basic characteristics of college students at this stage, for example, relative to middle school students. College students have more independent judgment ability and requirements, so the content of the system is generally based on principled guiding opinions, and at the same time, the system is given sufficient flexibility. It increases the institutional space of college students' behavior. As long as students engage in activities within this scope, their behavior will be recognized and recognized [12].

The personalized management of college students needs to be completed through institutionalized management. Personalized management is not without principles. It also depends on certain norms, that is, through the institutionalization of management. Here, the impact of institutionalization of management on individualization is embodied in [13]: first, the system regulates the bottom line and space of individualization. For example, the needs of college students are multifaceted, and positive and reasonable needs can be recognized through institutionalized norms, and conditions can be created to meet them. The unreasonable demand will not be recognized by the system norm, so the system recognizes the reasonable individuality. It gives space for personality development: second, the system stipulates the basic orientation of personalization, and the system expresses the basic requirements of the society and the school for the behavioral norms of college students. These requirements have different meanings for different people, but they all play a role in guiding [14]. Third, the system promotes the formation of order, when there is a conflict between the personalities of different college students. It can be effectively coordinated through institutional norms to form an order, so that different personalities can coexist, play a role together, and effectively achieve harmony without difference [15].

Any management needs the strict constraints of the system, so that there are laws and rules to follow, and the management of college students is no exception. College administrators should formulate sound and serious school rules and disciplines, and implement standardized management of college students to ensure the orderly development of school education and teaching, and to promote the healthy growth of college students. Under the premise of strict management, managers should give students more care, help, love, and encouragement, so that students feel respect, understanding, and care, so as to enhance students' self-confidence to overcome difficulties and setbacks, and guide students to establish correct values concept [16]. Humanized education emphasizes self-discipline and emotion. It mainly uses emotional means to restrain students. Through emotional effects, students can consciously abide by school rules and regulations, so as to realize self-discipline and self-management. This is the special role of humanized education. Strict management emphasizes

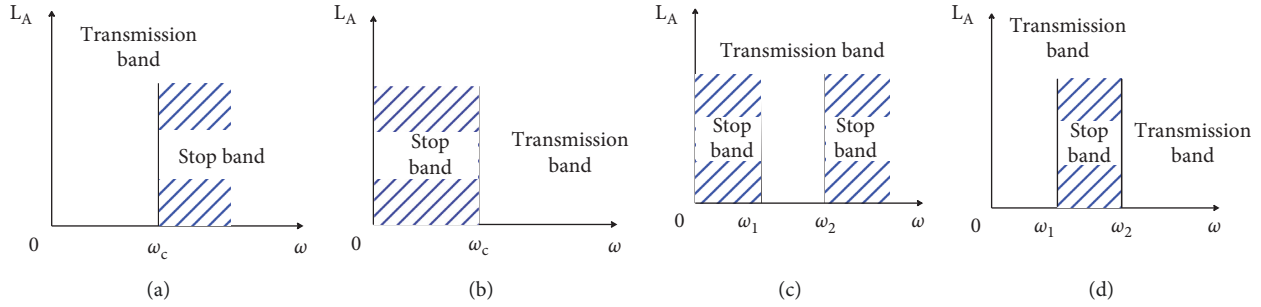

FIGURE 1: Frequency response plots of filters with different functions under ideal conditions. (a) Low pass; (b) high pass; (c) band pass; (d) band stop.

coercion and heteronomy, mainly using coercive means to urge students' behaviors to comply with rules and regulations under the constraints of external forces [17]. It can be seen that the difference between humanized education and strict management lies in the difference between restraint motivation and restraint behavior, emotional influence and institutional coercion, and self-discipline and other disciplines. However, from the perspective of student management, the two complement each other and restrict each other, and both are indispensable in the education management of college students. Humanized education is the goal and foundation, and strict management is the standard and basis. Strict management without humanized education is rigid and indifferent, and humanized education without strict management is messy and disorderly. Therefore, in the management of college students, both strict management and humanized education must be taken into account. It is necessary to strengthen the implementation of various management systems and to reflect the humanization of management; it is necessary to use strict management to restrain students' behavior, but also to use humanization. Education improves students' ideological awareness. Only in this way can we promote the coordinated development of humanized education and strict management, and use the management method of combining rigidity and flexibility to give full play to the role of management and education [18].

Based on the machine perspective and intelligent monitoring system, this article builds a humanized management system for college students and studies its hardware and software systems to improve the effect of humanized management of college students.

2. Hardware System Analysis

2.1. Basic Theory of Evanescent Mode Resonators and Microwave Filters. The microwave filter is a two-port device used to filter out signals in a specific frequency band, and its main function is to leave signals in a specific frequency band and filter out signals in other frequencies. In inverters, frequency multipliers, and other applications, it can be used to separate or combine different frequencies.

Microwave filters are classified in various ways according to different criteria. Some basic classifications are as follows. According to the filtering frequency band, it can be divided into four types of filters: low pass, high pass, band pass, and band stop. The frequency response is shown in Figure 1.

According to the different approximation functions, it can be divided into Chebyshev, maximum flat, and elliptic function filter. According to the structure type, it can be divided into waveguide, coaxial line, and microstrip line filter. In addition, according to the size of the bandwidth, it can be divided into narrowband and wideband filters.

The main performance index parameters of the filter are passband bandwidth, center frequency, return loss, insertion loss, and group delay.

Bandwidth: It refers to the difference between two frequency points that drop 3 dB (or 1 dB) on both sides of the center frequency of the band-pass filter as the standard.

Center frequency f_0 : it does not necessarily take the center point of the passband and is generally defined as the frequency point with the smallest insertion loss in the passband.

Return loss: it is defined as the reflected wave power P_1 divided by the incident wave power P_2 :

$$RL = -101g \frac{P_1}{P_2} = -101g \left(\frac{VSWR - 1}{VSWR + 1} \right)^2. \quad (1)$$

Insertion loss: it refers to the maximum attenuation in the passband, which represents the attenuation of the signal due to loss during transmission. The smaller it is, the better. P_{in} is the input power, and P_L is the output power:

$$IL = -101g \frac{P_L}{P_{in}}. \quad (2)$$

Group delay: it represents the rate of change of the phase shift with frequency at a certain frequency. In the filter, t_d is constant, so the signal phase is not distorted:

$$t_d = \frac{d\varphi(\omega)}{d\omega}. \quad (3)$$

2.2. Low-Pass Prototype of Microwave Filter. Generally speaking, based on the prototype of the low-pass filter, filters with different impedance levels and frequencies can be obtained through corresponding transformations.

Figure 2(a) is a graph showing the frequency attenuation of an ideal low-pass filter. It can be found from the figure that the signal is not attenuated in the $0 \sim \omega_1$ frequency range, and this frequency range is called the "passband." In the frequency range of $\omega_1' < \omega'$, the attenuation of the signal is

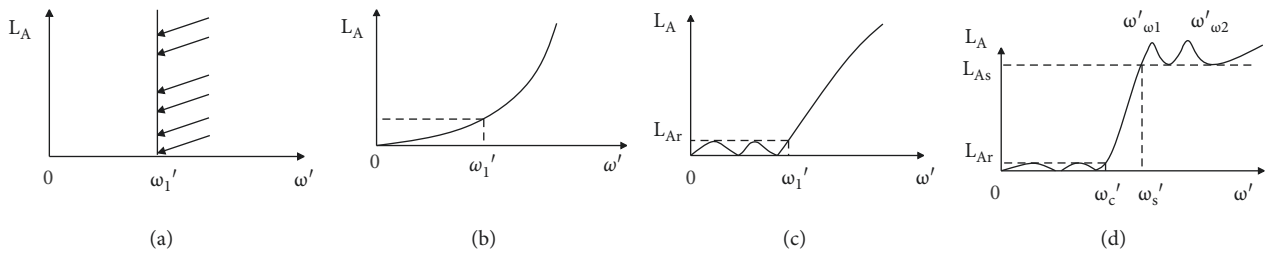

FIGURE 2: The frequency-attenuation curve of the low-pass filter. (a) Ideal low-pass curve; (b) Flattest response curve; (c) Chebyshev response curve; (d) elliptic function response curve.

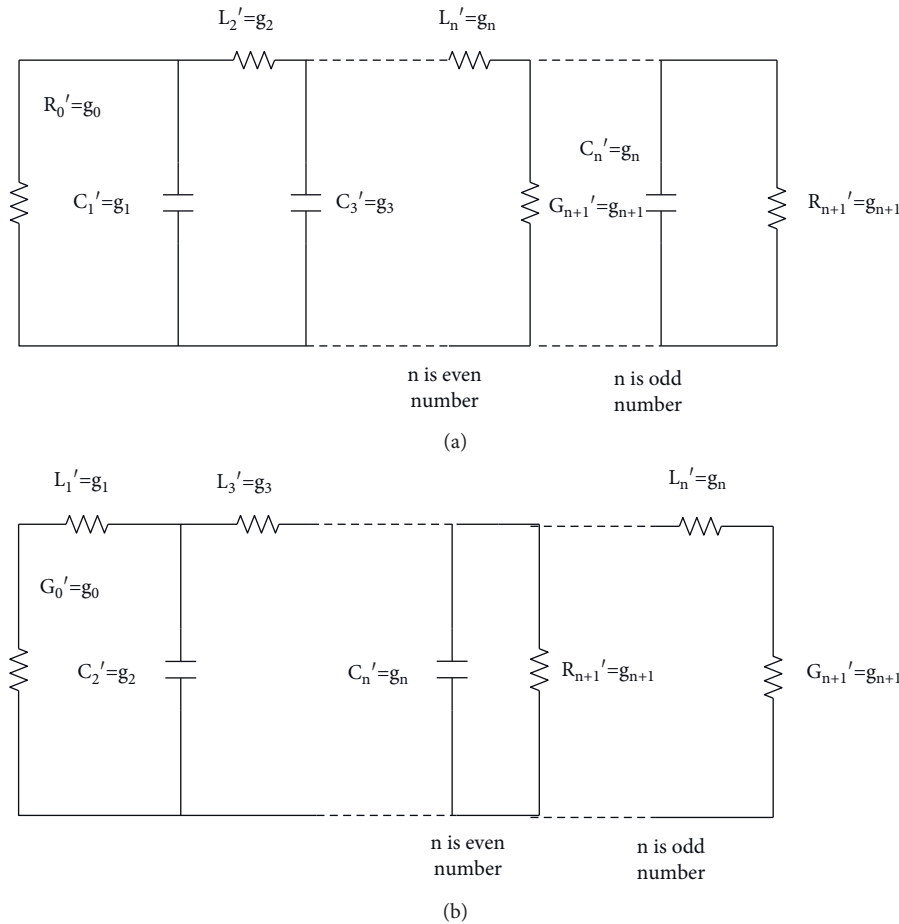

FIGURE 3: Ladder network of dual-terminal low-pass prototype filter. (a) The starting element is a shunt capacitor; (b) the starting element is a series inductor.

infinite, that is, the signal cannot pass through this frequency band, so this frequency range is called “stopband.” Therefore, the maximum frequency point ω'_1 of the passband is called the “cutoff frequency” of the filter. In fact, there is no filter with such an ideal response curve, and we can only try to approximate this curve. The actual signal is attenuated in the passband and will not be completely attenuated in the stopband, nor will the boundary between the passband and the stopband be a straight line. Therefore, according to the selected approximation function, the response curve is also different. Figures 2(b)–2(d) are the frequency-attenuation curves of three common low-pass filters. Figure 2(b) is referred to as the “flattest response” with the flattest

passband. The passband in Figure 2(c) exhibits regular fluctuations of equal amplitude, and this response is called “Chebyshev response.” Both the passband and stopband of Figure 2(d) show regular fluctuations of equal amplitude, which are called “elliptic function response.” In the figure, the largest attenuation in the passband is L_{Ar} . ω'_1 and ω'_c are called cutoff frequencies. For Figure 2(d), L_{As} is the minimum attenuation of the stopband, and ω'_s and ω'_c are the stopband and passband edge frequencies, respectively.

Figure 3 is a ladder circuit of a dual-terminal low-pass prototype filter obtained by a network synthesis method, and admittance or impedance can be connected to its terminal. Since Figures (a) and (b) are dual to each other, they can

both be regarded as low-pass prototype filters, and the frequency-attenuation characteristics of the two circuits are the same.

Each element in the network is regarded as a series inductor or a parallel capacitor, and the value of the element is represented by $g_0, g_1, g_2, \dots, g_n, g_{n+1}$. If g_1 is assumed to be inductance, then g_0 is conductance. If g_1 is assumed to be capacitance, then g_0 is resistance.

In order to reduce the calculation difficulty in practical application design, the above component values and frequencies are usually normalized and standardized. The specific transformation of the parameters is given as follows.

The resistance or conductance transformation is

$$R = \left(\frac{R_0}{R'_0}\right)R' \text{ or } G = \left(\frac{G_0}{G'_0}\right)G'. \quad (4)$$

The inductance transformation is

$$L = \left(\frac{R_0}{R'_0}\right)\left(\frac{\omega'_1}{\omega_1}\right)L' = \left(\frac{G'_0}{G_0}\right)\left(\frac{\omega_1}{\omega'_1}\right)L'. \quad (5)$$

The capacitive transformation is

$$C = \left(\frac{R'_0}{R_0}\right)\left(\frac{\omega_1}{\omega'_1}\right)C' = \left(\frac{G_0}{G'_0}\right)\left(\frac{\omega'_1}{\omega_1}\right)C'. \quad (6)$$

The quantities R', G', C' in the above formula are normalized values, whereas the quantities R, G, C , and L are the element values without normalization.

2.3. Common Filter Response Types. Depending on the response function selected for designing the filter, the components in Figure 3 are also different. Two common response types are introduced here.

The expression equation of the flattest response curve shown in Figure 2(b) is

$$L_A(\omega') = 10 \log_{10} \left[1 + \varepsilon \left(\frac{\omega'}{\omega'_1} \right)^{2n} \right], \quad (7)$$

where

$$\varepsilon = 10^{(L_{Ar}/10)} - 1, \quad (8)$$

n in the above formula represents the number of reactance elements in Figure 3. It can be seen from (7) that the passband of this response has the flattest characteristic because at $\omega' = 0$, there is the largest possible number of zero derivatives. When the maximum attenuation L_{Ar} in the passband is 3 dB, the circuit diagram is the normalized component parameter value of the flattest filter in Figure 3. The calculation is as follows:

$$g_0 = g_{n+1} = 1, \quad (9)$$

$$g_k = 2 \sin \left[\frac{(2k-1)\pi}{2n} \right] \quad (k = 1, 2, 3, \dots, n).$$

The expression equation of the Chebyshev response curve shown in Figure 2(c) is as follows:

$$L_A(\omega') = 10 \log_{10} \left\{ 1 + \varepsilon \cos^2 \left[n \cos^{-1} \left(\frac{\omega'}{\omega'_1} \right) \right] \right\}_{\omega' \leq \omega'_1},$$

$$L_A(\omega') = 10 \log_{10} \left\{ 1 + \varepsilon \cosh^2 \left[n \cosh^{-1} \left(\frac{\omega'}{\omega'_1} \right) \right] \right\}_{\omega' \geq \omega'_1}. \quad (10)$$

where

$$\varepsilon = 10^{(L_{Ar}/10)} - 1. \quad (11)$$

Similarly, n in the formula also represents the number of reactance elements in Figure 3. At the same time, it can be seen from the above formula that when n is an even number, there are $n/2$ frequency points corresponding to $L_A = 0$. When n is an odd number, there are $(n+1)/2$ frequency points corresponding to $L_A = 0$. Compared with the flattest response, the Chebyshev response has a steeper stopband attenuation, namely, better selectivity, and better out-of-band rejection under the same filter order. Since the Chebyshev response has these advantages, it is basically chosen as the low-pass prototype.

The normalized component values in the low-pass prototype circuit are calculated as follows:

$$g_1 = \frac{2a_1}{\gamma}, \quad (12)$$

$$g_k = \frac{4a_{k-1}a_k}{b_{k-1}g_{k-1}} \quad (k = 2, 3, \dots, n), \quad (13)$$

$$g_{n+1} = \begin{cases} 1, & (\text{nisodd}), \\ \tanh^2 \left(\frac{\beta}{4} \right), & (\text{niseven}), \end{cases} \quad (14)$$

$$\beta = \ln \left(\coth \frac{L_{Ar}}{17.37} \right), \quad (15)$$

$$\gamma = \sinh \left(\frac{\beta}{2n} \right),$$

$$a_k = \sin \left[\frac{(2k-1)\pi}{2n} \right] \quad (k = 1, 2, \dots, n), \quad (16)$$

$$b_k = \gamma^2 + \sin^2 \left[\frac{k\pi}{n} \right] \quad (k = 1, 2, \dots, n).$$

2.4. Filter Synthesis Process. After determining the type of filter response function and the order of the filter, the value of the normalized component in the circuit can basically be obtained. Then, using the duality theorem, a unit converter is added to the circuit to replace the series inductance with a parallel capacitor, and the capacitance value after the inductance is converted into a capacitor does not change. At the same time, because the unit converter is added, the impedance of the output and input is transformed into admittance. After doing this, the ladder network is converted

into a parallel resonant low-pass prototype circuit with admittance only. Moreover, the introduced unit converter and the actual filter coupling element correspond in turn. The next step is to add inductance to form a resonant tank, so that the low-pass prototype network can be transformed into a band-pass prototype network. Finally, the design of the actual filter structure is realized based on the band-pass prototype network. The synthesis process of the second-order coaxial cavity band-pass filter is shown in Figure 4.

2.5. Fundamentals of Evanescent Mode Resonators. Evanescent mode resonators are derived from waveguide resonators. For circular waveguide resonators, the electric and magnetic fields are widely distributed inside the waveguide in an orthogonal relationship. If a cylinder with a small distance from the cavity is added in the center of the waveguide, the frequency of the transmission mode of the resonator is lower than the frequency of the main mode of the original waveguide resonator. Resonators with such cavity structures are called evanescent mode resonators. After adding a capacitor column in the center of the circular waveguide, the magnetic field structure in the resonant cavity is not changed and still surrounds the center of the cavity. In addition, the electric field is concentrated between the capacitor column and the cavity, and has the strongest electric field strength on the axis of the cavity. The structure of the evanescent mode resonator is shown in Figure 5:

The expression for the resonant frequency f_0 of the evanescent mode resonator is as follows:

$$f_0 = \frac{1}{2\pi\sqrt{L_0 C}}, \quad (17)$$

$$C = C_0 + C_1 + C_2, \quad (18)$$

where L_0 represents the inherent inductance of the resonant cavity, and C represents the capacitance of the resonant cavity. It consists of three parts: the intrinsic capacitance C_0 of the resonant cavity, the plate capacitance C_1 of the resonant column and the upper end of the cavity, and the fringe capacitance C_2 of the capacitance column and the upper end of the cavity. Figure 6 is an equivalent circuit diagram of an evanescent mode resonator. It can be seen from the equivalent circuit diagram that the evanescent mode resonator is approximately a coaxial transmission line with one end shorted, and the other end is connected in series with the capacitor formed between the capacitor column and the cavity. Therefore, the intrinsic inductance L_0 and intrinsic capacitance C_0 of the capacitively loaded evanescent mode resonator can be represented by the intrinsic inductance and intrinsic capacitance of the coaxial line.

The inherent capacitance and inductance of the coaxial line are shown in the following formulas, respectively:

$$C_0 = \frac{2\pi h \epsilon_0}{\ln(R/r)}, \quad (19)$$

$$L_0 = \frac{\mu_0 h}{2\pi} \ln\left(\frac{R}{r}\right), \quad (20)$$

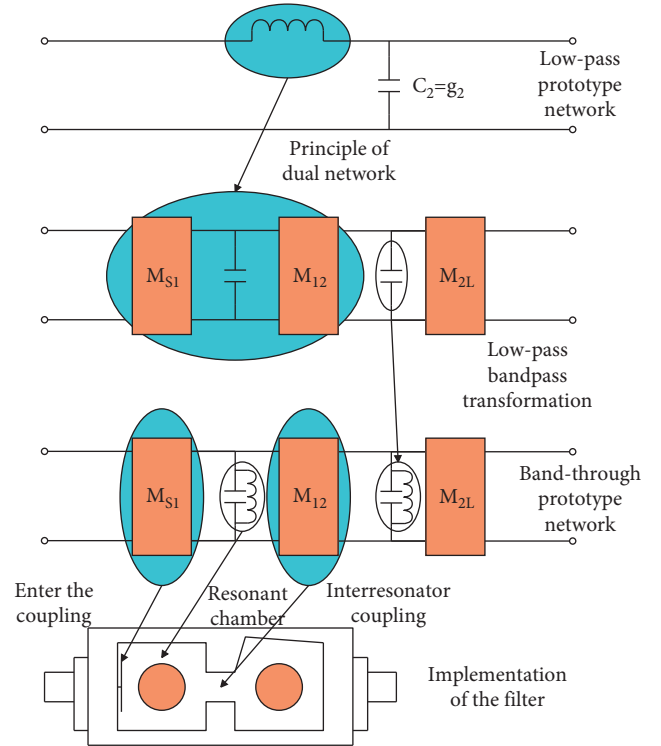

FIGURE 4: Synthesis process of a second-order coaxial cavity band-pass filter.

where h is the height of the capacitor column of the evanescent mode resonator, R is the radius of the cavity, r is the radius of the capacitor column, ϵ_0 is the vacuum permittivity, and μ_0 is the vacuum permeability.

Figure 7 shows the capacitance formed by the capacitance column and the top of the cavity, which is divided into two parts: the plate capacitance C_1 and the fringe capacitance C_2 , and the expressions are as in formulas (21) and (22). Among them, d is the distance between the capacitor column and the top of the cavity, and ϵ_r is the relative permittivity.

$$C_1 = \frac{\epsilon_r \epsilon_0 \pi r^2}{d}, \quad (21)$$

$$C_2 = Kr \epsilon_0 \ln\left(\frac{h}{d}\right), \quad (22)$$

where K is an empirical fitting constant sensitive to r/R , which is about 2.78 when r/R is less than or equal to 0.3. Combining formulas (17)–(22), the final resonant frequency f_0 of the capacitively loaded evanescent mode resonator can be obtained as

$$f_0 = \frac{1}{2\pi\sqrt{\epsilon_0 \mu_0 h^2 + \mu_0 h r \epsilon_0 / 2\pi \ln(R/r) (\epsilon_r \pi r / d + K \ln(h/d))}}. \quad (23)$$

We take the capacitance column radius $r = 1$ mm, the cavity radius $R = 6.5$ mm, the capacitance column height $h = 4.5$ mm, the distance between the capacitance column

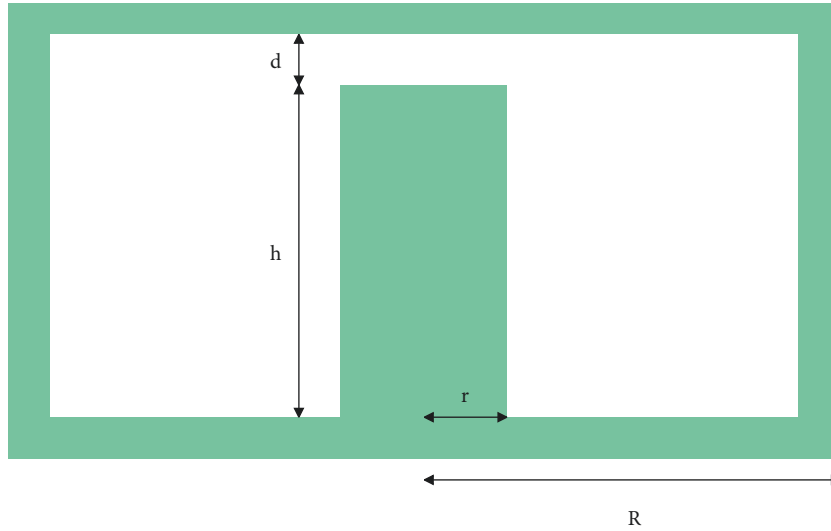

FIGURE 5: Structure diagram of evanescent mode resonator.

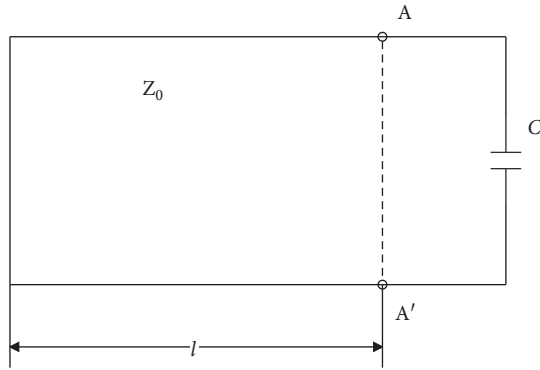

FIGURE 6: Equivalent circuit diagram of the evanescent mode resonator.

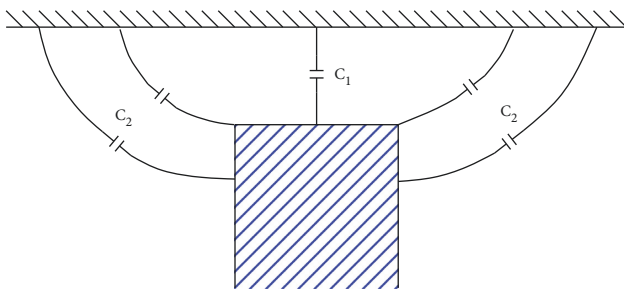

FIGURE 7: Capacitance formed by the capacitor column and the top of the cavity.

and the top of the cavity $d = 10 \text{ um}$, and calculate and obtain the inherent capacitance $C_0 = 1.33 \times 10^{-13} \text{ F}$, plate capacitance $C_1 = 2.78 \times 10^{-12} \text{ F}$, and fringe capacitance $C_2 = 1.5 \times 10^{-13} \text{ F}$. It can be seen that when the height of the capacitor column is close to the height of the cavity, the fringe capacitance C_2 and the intrinsic capacitance C_0 are very small compared to the plate capacitance C_1 , so that the plate capacitance C_1 dominates the total capacitance. At this time, the gap d becomes the main influencing parameter of the resonant frequency, and the change of the gap can be realized by displacing the top of the cavity.

3. Humanized Management System for College Students Based on Machine Perspective and Intelligent Monitoring System

If the school’s existing smart campus system does not form a unified cloud data platform, it needs to establish a special cloud data management system based on the corresponding interface. On the contrary, the distributed database storage system of the existing smart campus can be directly used, and the support of the basic cloud data platform can be obtained in any way, as shown in Figure 8.

On the simulation platform of the above system, the experimental research is carried out.

In order to verify the correctness of the formula, we only change the distance d , the parameter that has the greatest impact on the resonant frequency, and fix the rest of the parameters to compare the resonant frequency f_0 calculated by the theoretical calculation and the HFSS simulation. The results are shown in Figure 9. It can be found that the theoretical and simulated curves are basically consistent, and f_0 increases with the increase of the spacing, which confirms the correctness of the deduction of the resonance frequency formula.

Similarly, analogous to the coaxial transmission model, the unloaded quality factor Q_u of the cylindrical evanescent mode resonator can be approximated by the following formula:

$$\frac{1}{Q_u} = \frac{R_s}{2\pi\mu f_0} \left(\frac{(1/r + 1/R)}{\ln(R/r)} + \frac{2}{h} \right), \quad (24)$$

where R_s is the sheet resistance of the sidewall of the cavity, and μ is the permeability of air. It can be seen from the above equation that the unloaded quality factor of the resonator at a specific frequency mainly depends on the size of the resonator and the sheet resistance. Generally speaking, without affecting the frequency too much, increasing the height h of the capacitor column and the radius R of the cavity

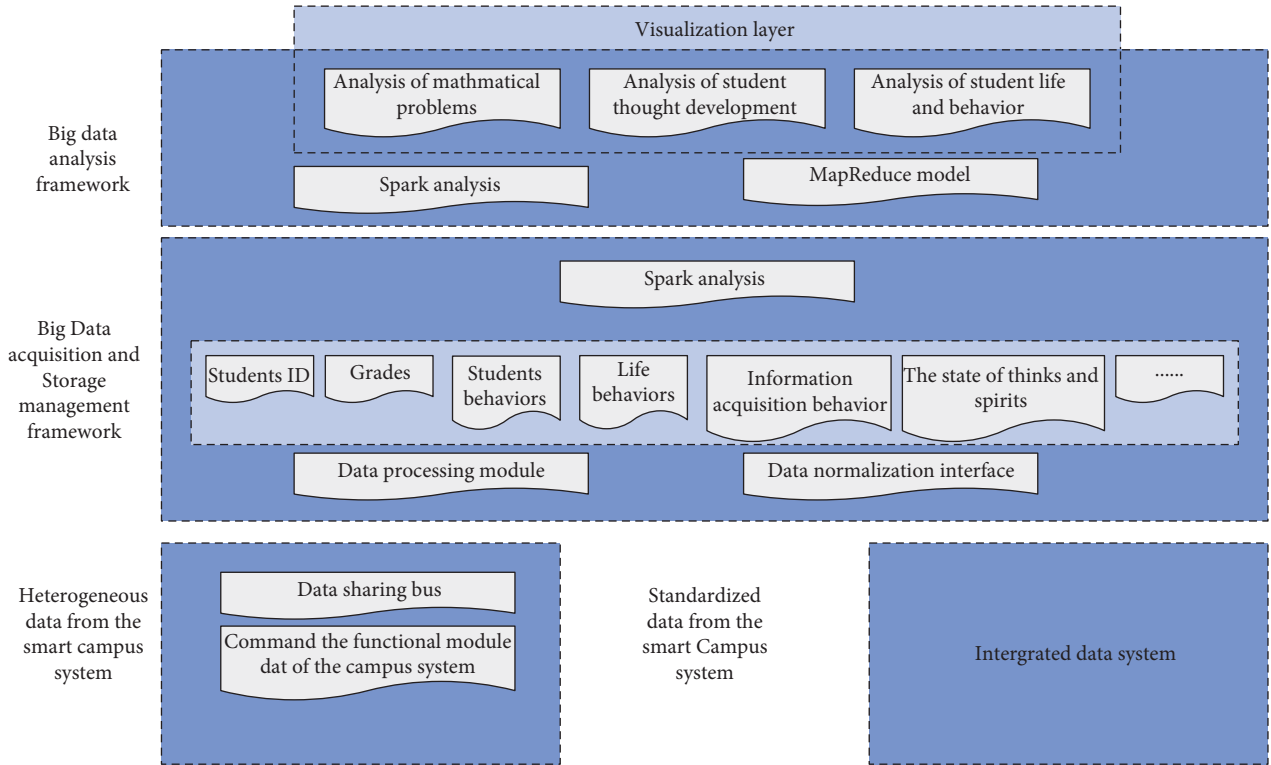

FIGURE 8: Architecture of the big data application system based on the smart campus system.

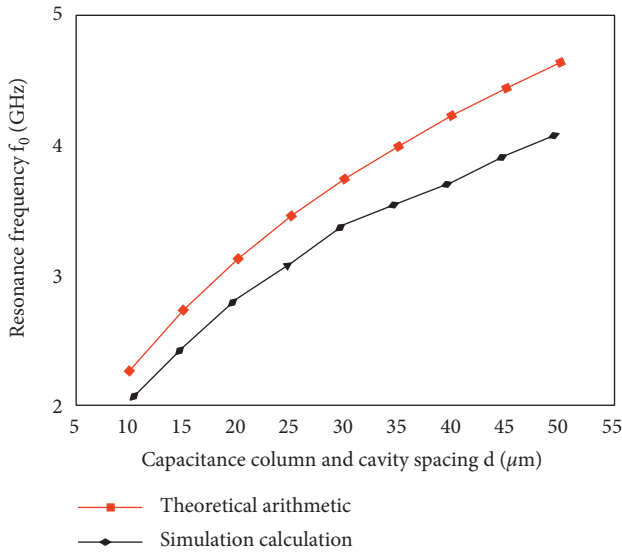

FIGURE 9: Comparison of theoretical and simulation results of resonant frequency of the resonator.

will increase the unloaded quality factor of the cavity, provided that h and R are smaller than the resonant wavelength. The formula for calculating the sheet resistance is as follows:

$$R_s = \frac{\rho}{t} \approx \frac{1}{\delta\sigma}, \quad (25)$$

$$\delta = \frac{1}{\sqrt{\pi\mu f_0\sigma}}$$

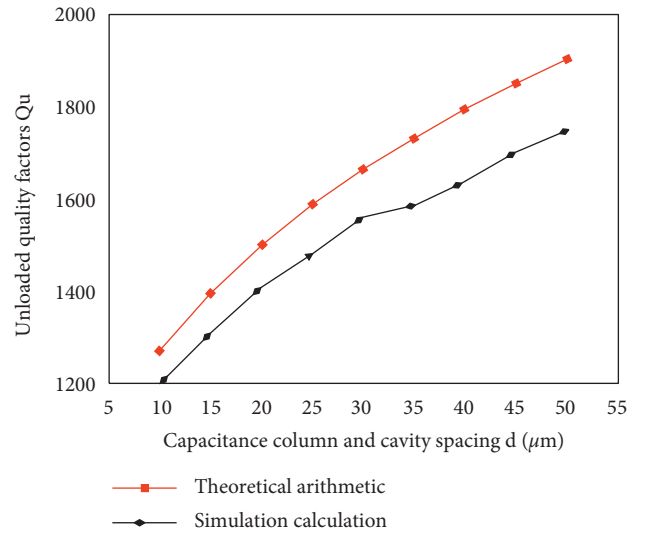

FIGURE 10: Comparison of theoretical and simulation results of the unloaded Q value of the resonator.

where ρ and σ are the resistivity and conductivity of the metal in the cavity, respectively, and t is the thickness of the metal. When t is much larger than the skin depth of δ , t can be replaced by δ . Therefore, for the fabrication of high-Q resonators, highly conductive metals (C_u , A_u , and A_g) are required. We take the capacitance column radius $r = 1$ mm, the cavity radius $R = 6.5$ mm, the capacitance column height

TABLE 1: The role of intelligent monitoring system based on machine perspective in improving the humanized management of college students.

Number	Management effect
1	89.442
2	89.247
3	84.645
4	87.681
5	91.960
6	89.866
7	84.148
8	84.639
9	88.332
10	87.560
11	87.676
12	83.427
13	83.993
14	89.182
15	89.147
16	83.661
17	89.897
18	89.608
19	89.542
20	84.478
21	87.618
22	90.836
23	83.804
24	87.463
25	91.789
26	83.399
27	91.974
28	88.732
29	88.167
30	87.225
31	89.072
32	90.399
33	88.609
34	84.239
35	88.557
36	85.521
37	85.800
38	86.994
39	83.244
40	89.720

It can be seen from the above research that the intelligent monitoring system based on the machine perspective proposed in this article has good effects and can effectively improve the quality of humanized management of college students.

$h = 4.5$ mm, and the distance between the capacitance column and the top of the cavity $d = 10$ um. The theoretical calculation and simulation calculation results of the obtained unloaded Q value are shown in Figure 10. The results show that the two curves are basically consistent, which shows the correctness of the theoretical deduction of the Q value formula.

On this basis, the effect of the intelligent monitoring system based on the machine perspective proposed in this article is verified, and its role in improving the humanized management of college students is explored. The evaluation results are shown in Table 1.

4. Conclusion

College students are the subject of management and self-management in school management. This dual identity points to the same purpose, that is, to enable them to better study and live in university, to better seek knowledge, be a better person, better improve their abilities, acquire skills, and so on. This purpose inherently determines that the study and life of college students is a process in which their good characteristics are respected and recognized, and a process in which bad characteristics are gradually corrected and standardized. Therefore, in this sense, the humanized management of college students reflects the fundamental value orientation of management. This article builds a humanized management system for college students based on the machine perspective and intelligent monitoring system. From the experimental research, it can be seen that the intelligent monitoring system based on the machine perspective proposed in this article has good results and can effectively improve the quality of humanized management of college students.

Data Availability

The labeled dataset used to support the findings of this study is available from the corresponding author upon request.

Conflicts of Interest

The author declares no conflicts of interest.

Acknowledgments

This work was supported by Shaoxing University Yuanpei College.

References

- [1] C. Greenhow, C. Lewin, and K. B. Staudt Willet, "The educational response to Covid-19 across two countries: a critical examination of initial digital pedagogy adoption," *Technology, Pedagogy and Education*, vol. 30, no. 1, pp. 7–25, 2021.
- [2] D. I. Bayanov, L. Y. Novitskaya, S. A. Panina et al., "Digital technology: risks or benefits in student training," *Journal of Environmental Treatment Techniques*, vol. 7, no. 4, pp. 659–663, 2019.
- [3] C. Rapanta, L. Botturi, P. Goodyear, L. Guàrdia, and M. Koole, "Online university teaching during and after the Covid-19 crisis: refocusing teacher presence and learning activity," *Postdigital science and education*, vol. 2, no. 3, pp. 923–945, 2020.
- [4] C. Herodotou, M. Hlosta, A. Boroowa, B. Rienties, Z. Zdrahal, and C. Mangafa, "Empowering online teachers through predictive learning analytics," *British Journal of Educational Technology*, vol. 50, no. 6, pp. 3064–3079, 2019.
- [5] E. C. Callo and A. D. Yazon, "Exploring the factors influencing the readiness of faculty and students on online teaching and learning as an alternative delivery mode for the new normal," *Universal Journal of Educational Research*, vol. 8, no. 8, pp. 3509–3518, 2020.
- [6] J. Fletcher, J. Everatt, J. Mackey, and L. H. Fickel, "Digital technologies and innovative learning environments in

- schooling: a New Zealand experience,” *New Zealand Journal of Educational Studies*, vol. 55, no. 1, pp. 91–112, 2020.
- [7] F. G. Reamer, “Social work education in a digital world: technology standards for education and practice,” *Journal of Social Work Education*, vol. 55, no. 3, pp. 420–432, 2019.
- [8] A. Priyadarshini and R. Bhaumik, “E-Readiness of senior school learners to online learning transition amid COVID-19 lockdown,” *Asian Journal of Distance Education*, vol. 15, no. 1, pp. 244–256, 2020.
- [9] K. Okoye, J. A. Rodriguez-Tort, J. Escamilla, and S. Hosseini, “Technology-mediated teaching and learning process: a conceptual study of educators’ response amidst the Covid-19 pandemic,” *Education and Information Technologies*, vol. 26, no. 6, pp. 7225–7257, 2021.
- [10] S. Giri and P. Dutta, “Identifying challenges and opportunities in teaching chemistry online in India amid COVID-19,” *Journal of Chemical Education*, vol. 98, no. 2, pp. 694–699, 2020.
- [11] R. P. Rahayu and Y. Wirza, “Teachers’ perception of online learning during pandemic covid-19,” *Jurnal Penelitian Pendidikan*, vol. 20, no. 3, pp. 392–406, 2020.
- [12] R. Rasmitadila, R. R. Aliyyah, R. Rachmadtullah et al., “The perceptions of primary school teachers of online learning during the COVID-19 pandemic period: a case study in Indonesia,” *Journal of Ethnic and Cultural Studies*, vol. 7, no. 2, pp. 90–109, 2020.
- [13] F. Caena and C. Redecker, “Aligning teacher competence frameworks to 21st century challenges: the case for the European Digital Competence Framework for Educators,” *European Journal of Education*, vol. 54, no. 3, pp. 356–369, 2019.
- [14] A. Graham, “Benefits of online teaching for face-to-face teaching at historically black colleges and universities,” *Online Learning*, vol. 23, no. 1, pp. 144–163, 2019.
- [15] M. U. Farooq and A. Soormro, “Teachers and technology: trends in English language teaching in Saudi Arabia,” *International Journal of English Linguistics*, vol. 8, no. 5, pp. 10–19, 2018.
- [16] B. Williamson, S. Bayne, and S. Shay, “The datafication of teaching in Higher Education: critical issues and perspectives,” *Teaching in Higher Education*, vol. 25, no. 4, pp. 351–365, 2020.
- [17] P. Sepulveda-Escobar and A. Morrison, “Online teaching placement during the COVID-19 pandemic in Chile: challenges and opportunities,” *European Journal of Teacher Education*, vol. 43, no. 4, pp. 587–607, 2020.
- [18] R. Petronzi and D. Petronzi, “The online and campus (OaC) model as a sustainable blended approach to teaching and learning in higher education: a response to COVID-19,” *Journal of Pedagogical Research*, vol. 4, no. 4, pp. 498–507, 2020.