

Retraction

Retracted: Dynamic Analysis and Fabrication of Single Screw Conveyor Machine

Advances in Materials Science and Engineering

Received 11 July 2023; Accepted 11 July 2023; Published 12 July 2023

Copyright © 2023 Advances in Materials Science and Engineering. This is an open access article distributed under the Creative Commons Attribution License, which permits unrestricted use, distribution, and reproduction in any medium, provided the original work is properly cited.

This article has been retracted by Hindawi following an investigation undertaken by the publisher [1]. This investigation has uncovered evidence of one or more of the following indicators of systematic manipulation of the publication process:

- (1) Discrepancies in scope
- (2) Discrepancies in the description of the research reported
- (3) Discrepancies between the availability of data and the research described
- (4) Inappropriate citations
- (5) Incoherent, meaningless and/or irrelevant content included in the article
- (6) Peer-review manipulation

The presence of these indicators undermines our confidence in the integrity of the article's content and we cannot, therefore, vouch for its reliability. Please note that this notice is intended solely to alert readers that the content of this article is unreliable. We have not investigated whether authors were aware of or involved in the systematic manipulation of the publication process.

Wiley and Hindawi regrets that the usual quality checks did not identify these issues before publication and have since put additional measures in place to safeguard research integrity.

We wish to credit our own Research Integrity and Research Publishing teams and anonymous and named external researchers and research integrity experts for contributing to this investigation.

The corresponding author, as the representative of all authors, has been given the opportunity to register their agreement or disagreement to this retraction. We have kept a record of any response received.

References

- [1] S. Moorthi, M. Megaraj, L. Nagarajan, A. Karthick, M. Bharani, and P. P. Patil, "Dynamic Analysis and Fabrication of Single Screw Conveyor Machine," *Advances in Materials Science and Engineering*, vol. 2022, Article ID 3843968, 10 pages, 2022.

Research Article

Dynamic Analysis and Fabrication of Single Screw Conveyor Machine

Sundarraaj Moorthi,¹ Meikandan Megaraj,¹ Lenin Nagarajan,¹ Alagar Karthick,^{2,3} Murugesan Bharani ,⁴ and Pravin P. Patil⁵

¹Department of Mechanical Engineering, Veltech Rangarajan Dr. Sagunthala R & D Institute of Science and Technology, Avadi 600 062, India

²Renewable Energy Lab, Department of Electrical and Electronics Engineering, KPR Institute of Engineering and Technology, Coimbatore 641407, Tamilnadu, India

³Departamento de Quimica Organica, Universidad de Cordoba, Edificio Marie Curie (C-3), Ctra Nnal IV-A, Km 396, E14014 Cordoba, Spain

⁴School of Textile Leather and Fashion Technology Kombolcha 208, Kombolcha Institute of Technology, Wollo University, South Wollo, Ethiopia

⁵Department of Mechanical Engineering, Graphic Era Deemed to be University, Bell Road, Clement Town, 248002 Dehradun, Uttarakhand, India

Correspondence should be addressed to Murugesan Bharani; bharani.murugesan@kiot.edu.et

Received 10 February 2022; Revised 21 March 2022; Accepted 30 March 2022; Published 12 April 2022

Academic Editor: Penchal Reddy

Copyright © 2022 Sundarraaj Moorthi et al. This is an open access article distributed under the Creative Commons Attribution License, which permits unrestricted use, distribution, and reproduction in any medium, provided the original work is properly cited.

The design and development of machine tools play a vital role in the current economic growth. It facilitates the reduction of manufacturing cost coping with a quickly changing business environment. During the design of the machine tool, the dynamic characteristics need to be calibrated for avoiding uncertainties. This paper investigates the design, dynamic characteristics, and development of a single screw conveyor machine which is used to blend waste plastic material with catalysts. The conveyor machine model is created based on the idea developed from filament extruder machine with Pro-E solid modelling software. Its multibody dynamic analysis was carried out for the selected operational requirements in the ADAMS View. It shows that when the conveyor screw operated above the velocity of 42 m/s, the deformation will occur at a maximum value of 4.23 mm. The rigid body dynamic was carried out in ANSYS to solve the performance forecasting problems at their design stage. The dynamic analysis results were suggested to improve the conveying machine and driving mechanisms design parameters.

1. Introduction

Solid modelling is currently the primary method to create new ideas for products and structures. The main advantage of solid modelling is that it gives a realistic visual representation of the product and helps the user make changes quickly and easily. During the design process, the availability, accessibility, and environmental aspects are considered. However, individual components dynamic characteristics need to be analyzed to make the designed model into higher durability and effective one [1, 2]. Ahmad

et al. [3] surveyed that around 7 percentage of the gross national product failed due to product performance-related issues. Most products are developed from research and development. Ahmad and Ismail et al. [4, 5] reviewed the problems during the production of new products and their aftermarket. They suggested that before the product came into manufacturing, its characteristics need to be analyzed thoroughly to avoid failure rates and manufacturing cost. They also presented a framework for the analysis of products during their design process. Li et al. and Jiao et al. [6, 7] surveyed the requirement of new product developments in

the market to satisfy customer requirements. He framed the topological structure to help the designer to develop new products. The topological structure includes customer requirement and existing products in the market and their failure reasons. He identified that most of the product failures happen in improper design and not considering the machine's dynamic characteristic and safety factor. He [8] discussed and developed the empirical relationship of modelling techniques and static and dynamic characteristics of welded joints and analyzed its possible failure modes. Lahari and Srinivas Sharma [9] developed single screw extruder for recycling of waste plastic material and examined the parametric analysis of the developed model; from the analytical report, they identified decreased pressure due to barrel radius and higher length of the screw. Wang et al. and Tso et al. [10, 11] discussed the design and analysis of mechanical linkages used in mechanical press. They optimized the linkage length to provide the best actuation. He suggested that computer-aided modelling and analysis techniques make the design more perfect and reduce the failure causes during the design stage itself. Hence, the production cost can be saved. Singh et al. [12] studied the making of energy storage device through 3D printing technique by utilizing commercially available waste plastics based 3D printer filament developed through twin screw extruder machine. The filament was developed with additives of zinc metal and the additives of different chemicals for enabling conduciveness.

The present work investigates modelling and dynamic analysis of a single screw conveyor machine. The dynamic analysis was carried out with the ADAMS View's help by considering the conveyor machine operational parameters. The outcome results were considered for the conveyor machine's development to avoid failure due to dynamic characteristics.

2. Materials and Methods

2.1. Modelling of Single Screw Conveyor (SSC) Machine.

The basic idea for developing a conveyor machine is taken by considering a single screw filament extruder and its operational parameters. Filament extruders are used to melt the plastics and feed them through the nozzle in the desired shape. In the case of a screw conveyor, the materials are transferred from one place to another place using a rotating helical screw blade connecting these two ideas, and the development of a single screw conveyor was generated. The 3D solid modelling of a single screw conveyor was created with the help of Pro-E 5.0 software. The conveyor machine consists of a hopper, screw barrel, helical screw, and driving mechanisms. For creating a conveyor screw from the filament extruder, the screw nomenclature is studied, and it is shown in Figure 1. The main component of the conveyor screw machine designed in Pro-E software is shown in Figures 2–4, respectively.

2.2. *Multibody Dynamic Analysis of Single Screw Conveyor Machine Using MSC ADAMS.* The conveyor machine and its assembly components are created through Pro-E software; it

was saved into Parasolid file format to make the ease of exchanging the modelling data of created model into ADAMS View/ANSYS environment. ADAMS View is a program that allows the building of mechanical systems models and simulates the models' full-motion behaviour [14–16]. It can also be used to quickly analyze multiple design variations until the optimal design is found. ANSYS Rigid dynamics helps to understand mechanical systems' motion behaviour in the design cycle [17–20]. In the proposed research, the single screw conveyor model is analyzed with the help of ADAMS View and ANSYS 14.5 software. In ADAMS, the model's constraints and boundary conditions are applied using the build tool. The constraint consists of relative movement between the components.

A screw conveyor machine consists of links and joints. Each component in the conveyor will move or rotate with the preceding constraints. The model imported in the ADAMS View Environment and the boundary conditions (constraints) created to model are as shown in Figure 5.

The initial simulation was taken to validate and for finding any redundant constraint added to the model. Afterwards, the operational functions of the screw are applied, and its dynamic analysis was carried out. Initially, the conveyor machine is operated for a period of 20 seconds with the speed of 3000 rpm, and its performance behaviour is taken. The two sets of markers are located in the model one which is at the screw centre and another is at the barrel edge to find the displacement of the conveyor screw. The operation functions can be improved by adding more complex elements like friction or general state equation to make the model accurate. The results of the position and velocity of a conveyor screw in the X-axis are obtained in graphic form using the windows of measures interface shown in Figures 6(a) and 6(b), respectively.

The conveyor screw is rotating at a constant speed about its longitudinal axis. The displacement field is implicit by choosing coordinates x with the conveyor screw axis, as shown in Figure 7.

$$\begin{aligned} U(x, y, z, t) &= U_0(x, t) + z\beta_x(x, t) - y\beta_y(x, t), \\ V(x, y, z, t) &= V_0(x, t) - z\phi(x, t), \\ W(x, y, z, t) &= W_0(x, t) + y\phi(x, t). \end{aligned} \quad (1)$$

U , V , and W are the flexural displacements of the conveyor screw at any point of its cross section in x , y , and z directions. The variables U_0 , V_0 , and W_0 are the flexural displacements of the screw axis, while β_x and β_y are the rotation angles of the screw, about the y - and z -axis, respectively. ϕ is the angular displacement of the conveyor screw due to its torsional deformation.

In ADAMS View Environment, the rotational displacement, velocity, and accelerations can be calculated with the help of markers created in the conveyor screw at prescribed locations, and markers act as an imaginary point with coordinate values.

2.3. *Rigid Dynamic Analysis of Single Screw Conveyor Machine Using ANSYS.* In the ANSYS workbench environment, the model saved in the Parasolid format from Pro-E software is

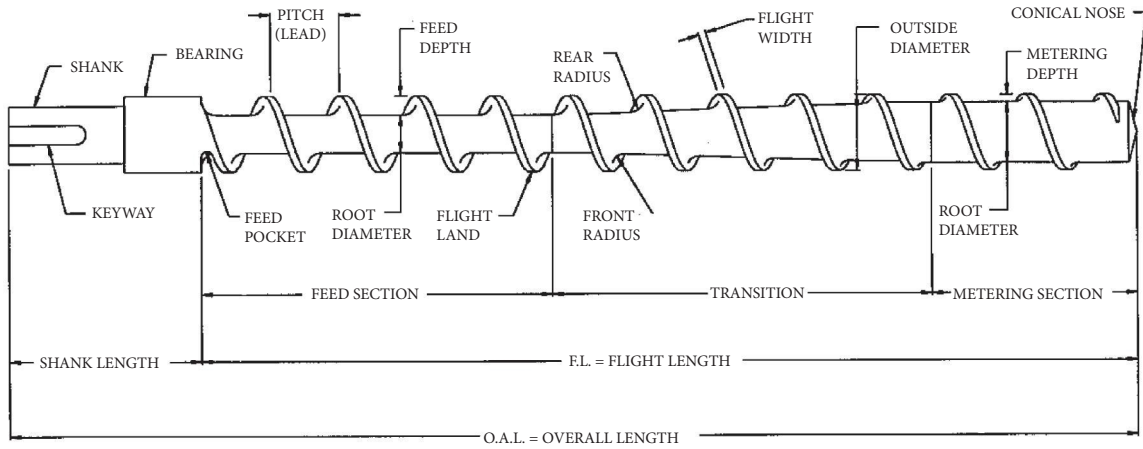

FIGURE 1: Screw nomenclature [13].

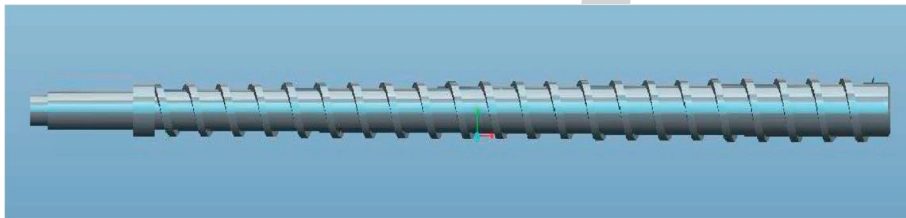

FIGURE 2: Pro-E model of conveyor screw.

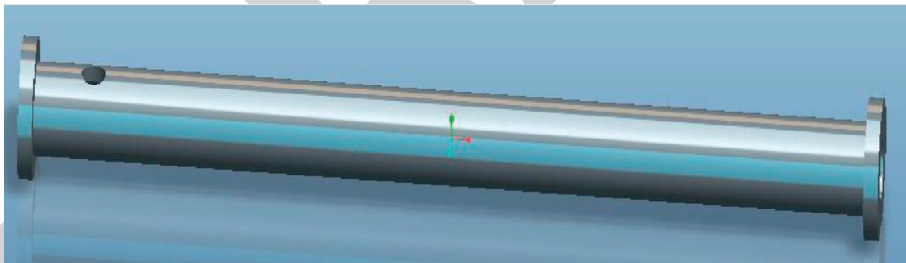

FIGURE 3: Pro-E model of conveyor screw barrel.

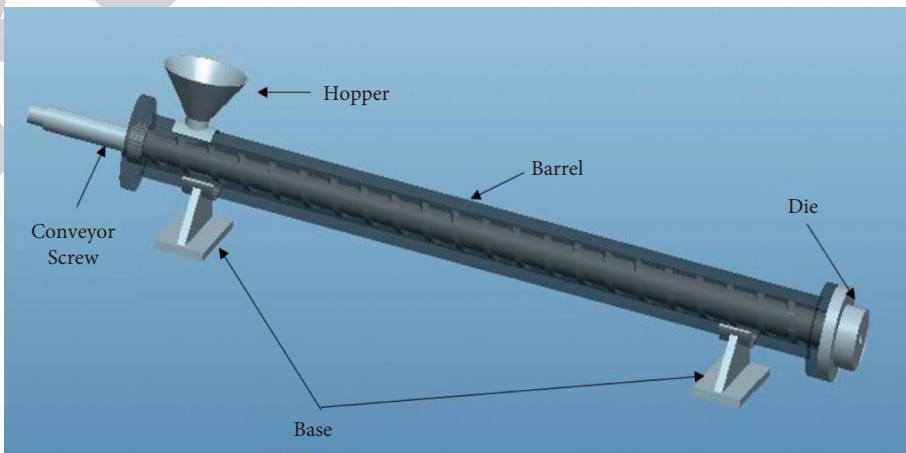

FIGURE 4: Assembly view of conveyor screw machine.

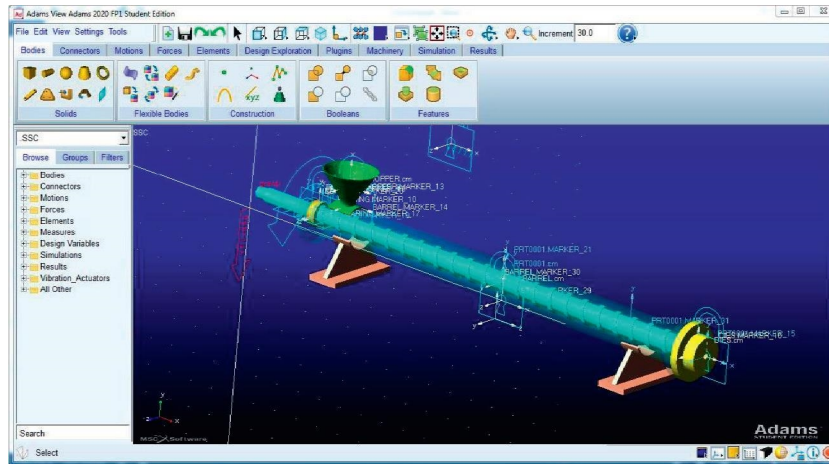
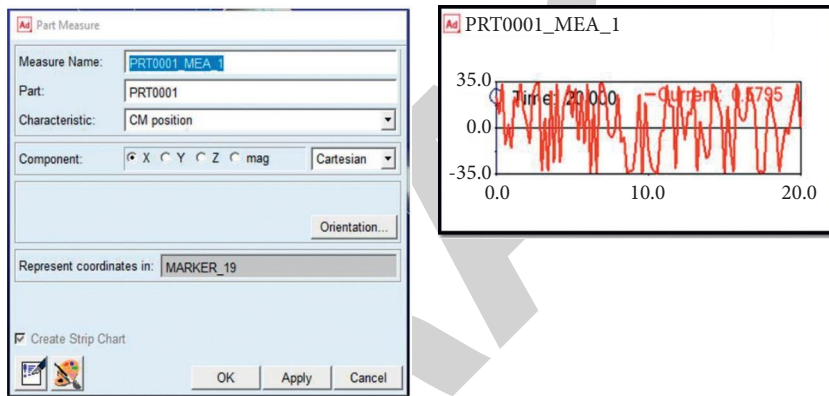

FIGURE 5: ADAMS View Environment and the constraint created to model.



(a)

(b)

FIGURE 6: (a) Window of the part measure and (b) position of conveyor screw-in X-axis direction.

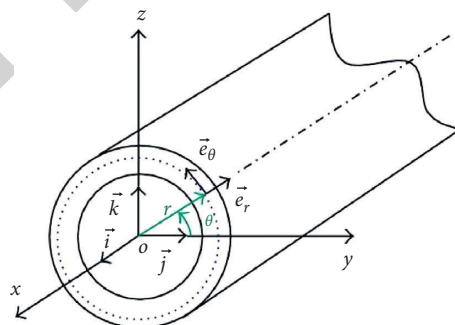

FIGURE 7: Cylindrical-coordinate system [14].

imported, and connections between the assembly models are added with the joints menu toolbar. The screw is operated with a speed of 3000 rpm, and its characteristics are analyzed. The model imported to the ANSYS workbench environment and the model's connections are as shown in Figure 8.

2.4. Development of Single Screw Conveyor. The single screw conveyor machine is developed by considering the resulting outcome from ADAMS and ANSYS software. The fabricated single screw conveyor machine and its components are shown in Figures 9 and 10, respectively.

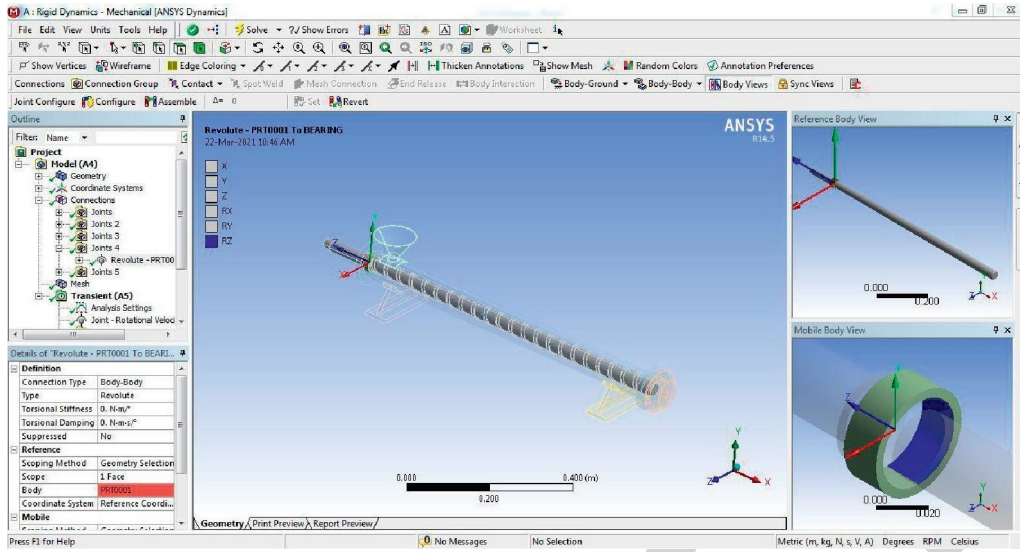

FIGURE 8: ANSYS environment and the constraint created to conveyor model.



FIGURE 9: Machining image of single screw conveyor.

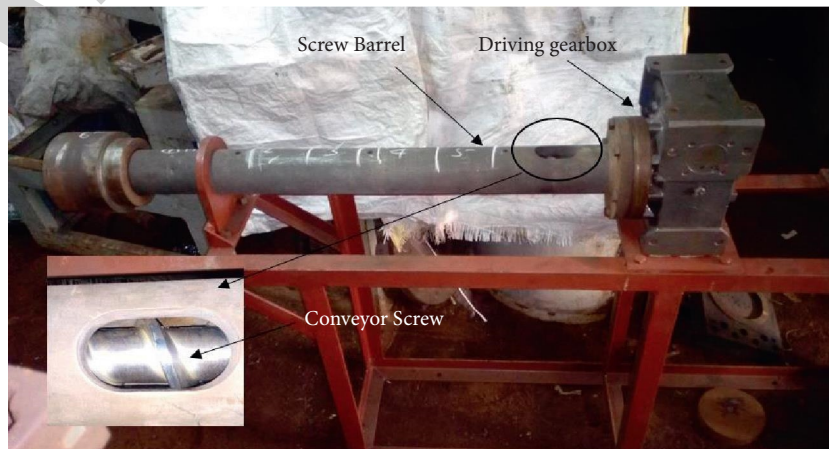

FIGURE 10: Single screw conveyor and driving gearbox setup.

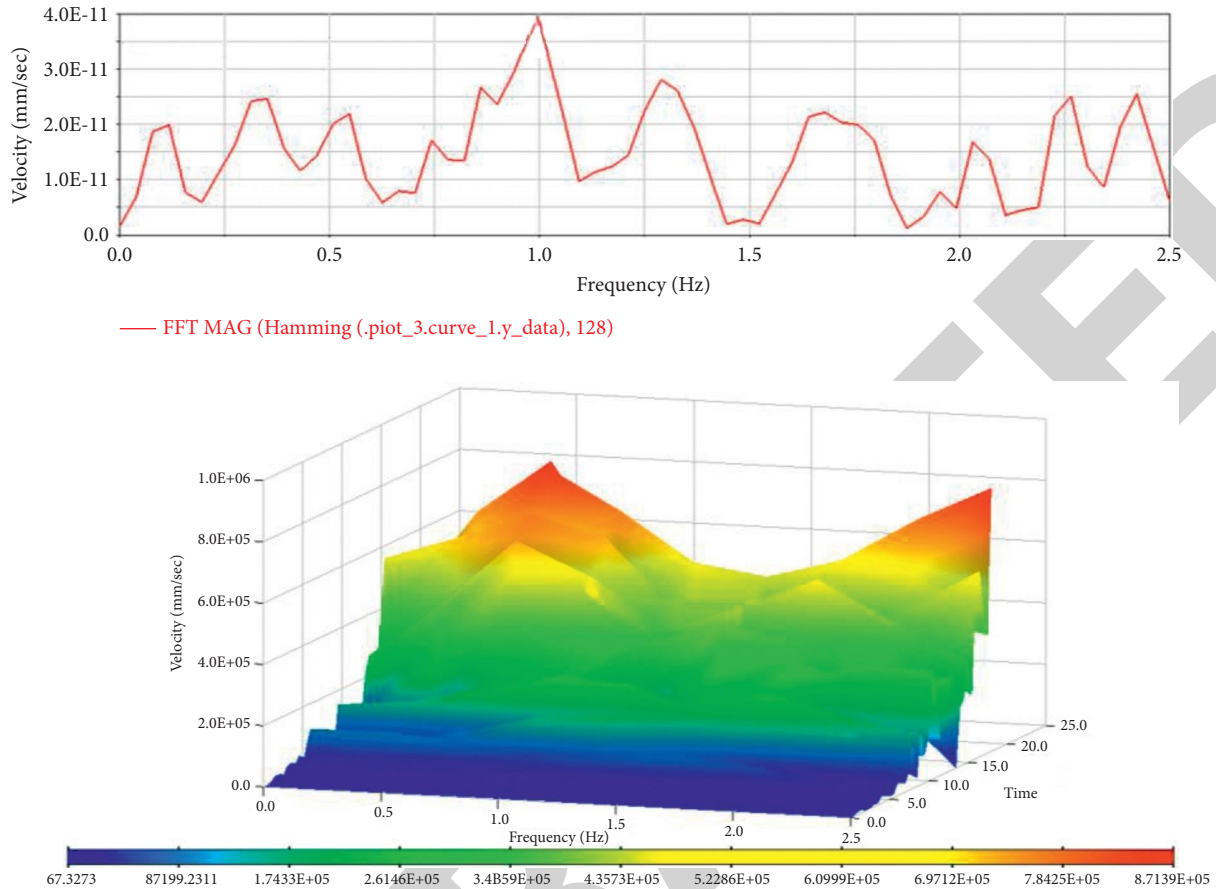

FIGURE 11: Velocity of single screw conveyor.

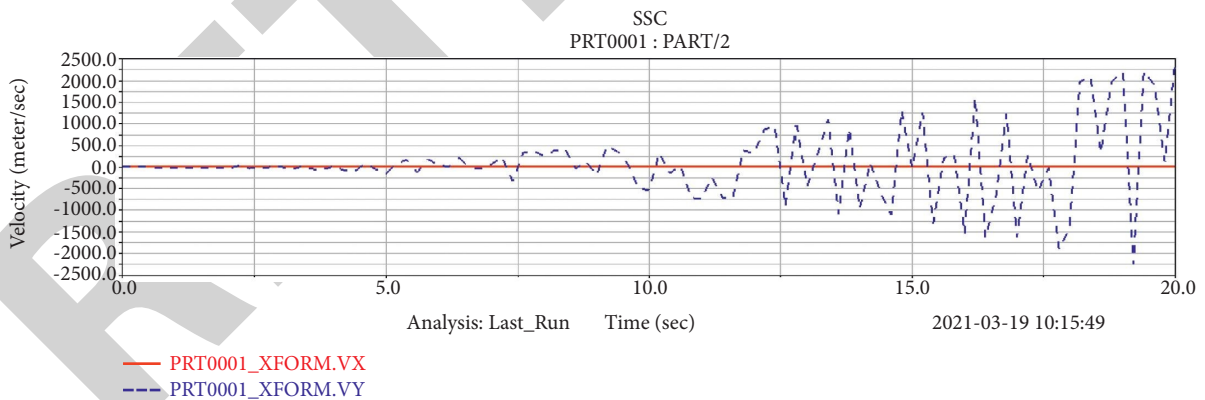

FIGURE 12: Velocity of single screw conveyor concerning time period.

3. Results and Discussion

3.1. Velocity, Deformation, and Acceleration of Single Screw Conveyor in ADAMS View. The dynamic response characteristics help to identify the vibration at a particular region and its velocity compound. To study the dynamic characteristic and effect, the single screw conveyor machine is freely allowed to operate in the ADAMS View Environment. Its dynamic responses are noted to determine the velocity,

acceleration, and displacement of the system or component. The frequency of a single screw conveyor concerning velocity is as shown in Figure 11.

The velocity and deformation of a conveyor screw analyzed in the ADAMS View Environment are presented in Figures 12 and 13, respectively. It shows that the maximum deformation value of a single screw conveyor (SSC) is 4.23 mm concerning the operating period. Based on the results data analyzed from the ADAMS View, the velocity of

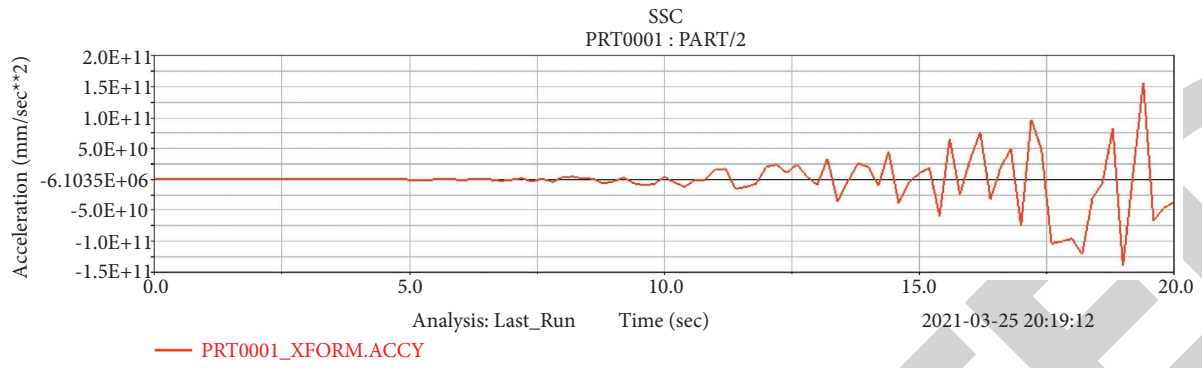

FIGURE 13: Acceleration of single screw conveyor.

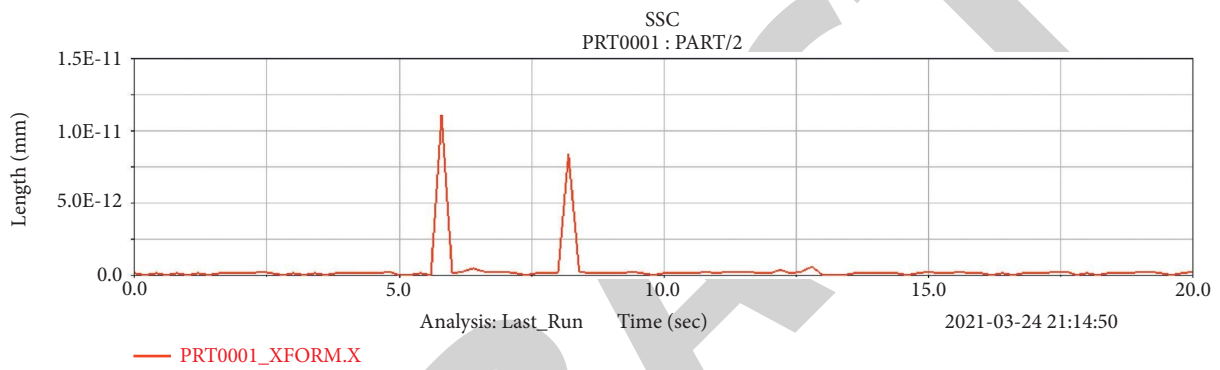

FIGURE 14: Deformation of single screw conveyor.

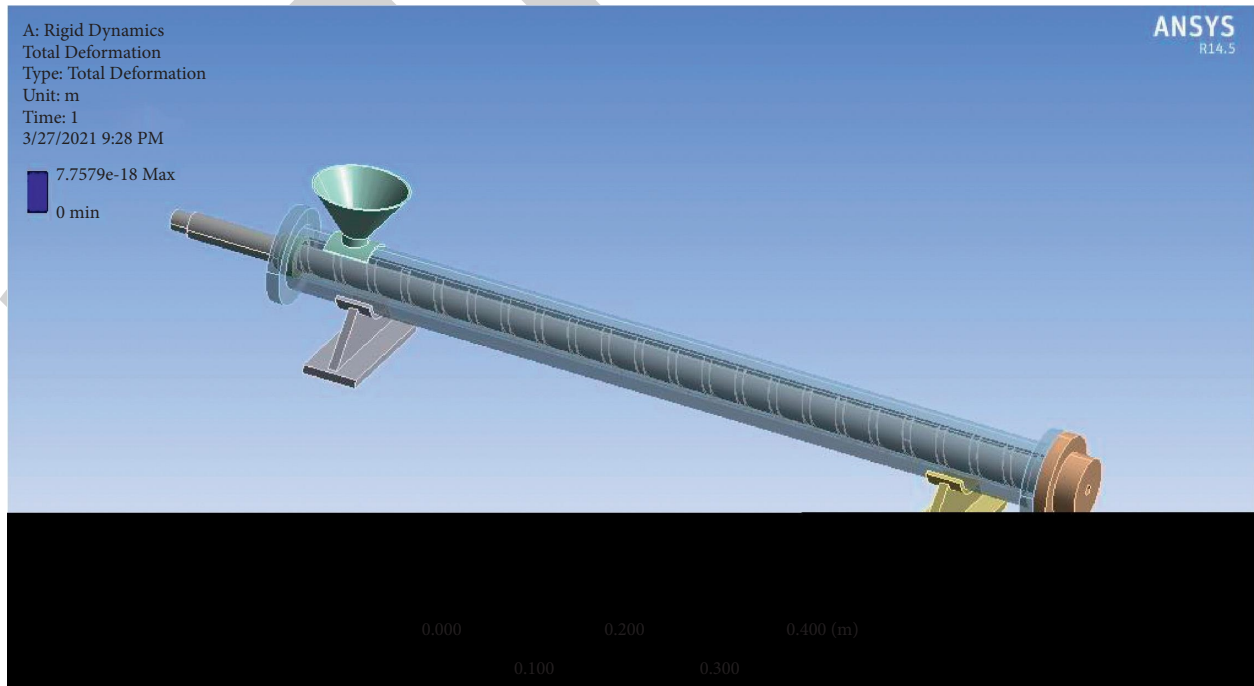

FIGURE 15: Total deformation of single screw conveyor.

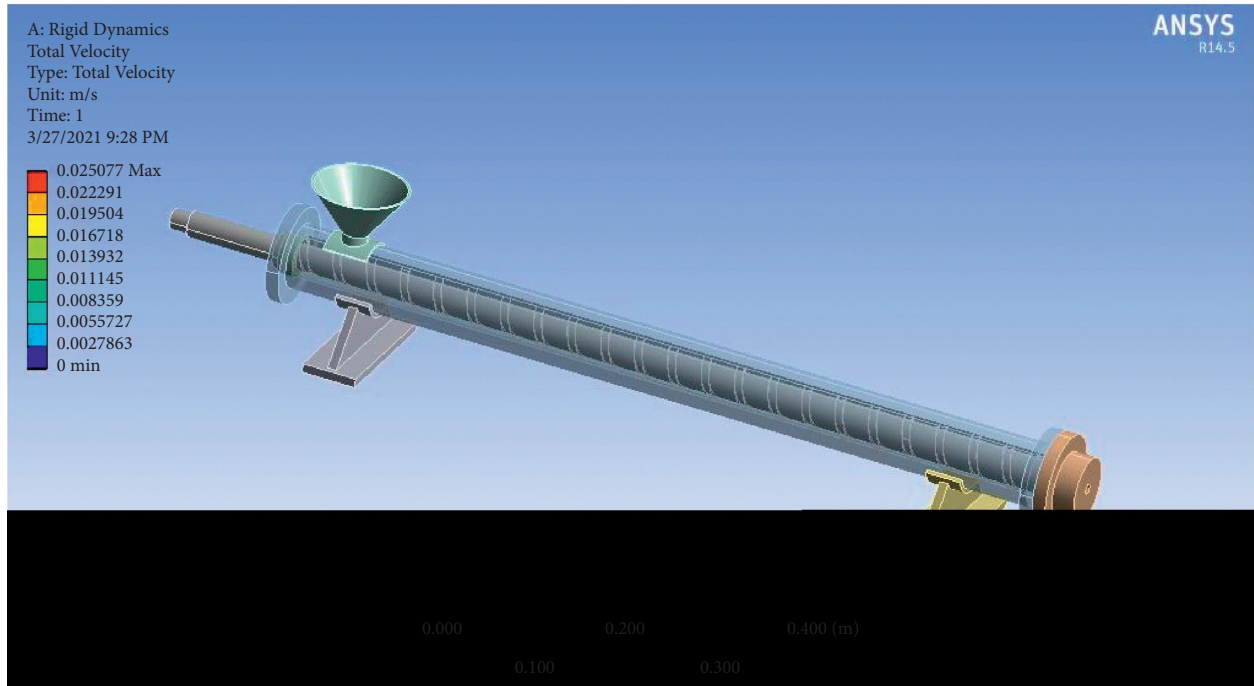

FIGURE 16: Total velocity of single screw conveyor.

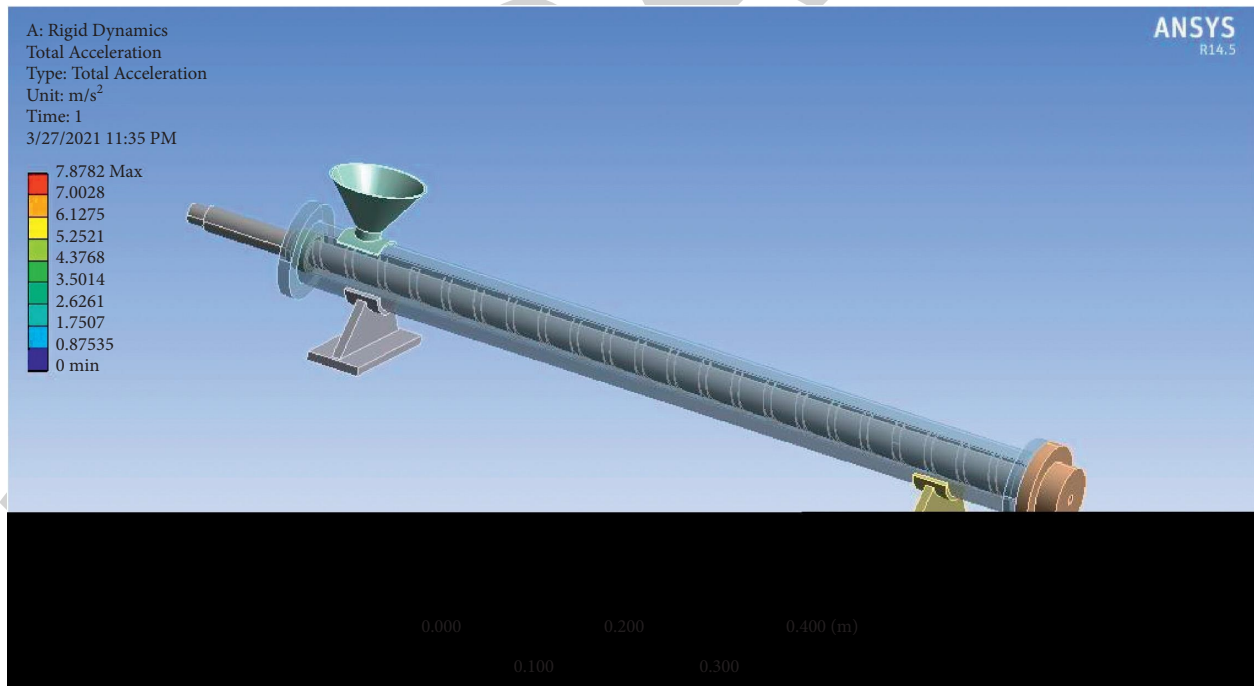

FIGURE 17: Total acceleration of single screw conveyor.

the conveyor screw increased above 42 m/s leads to vibration and also the velocity distribution of components leads to failure of bearing systems. Hence, the single screw conveyor should be operated below its critical velocity.

The acceleration value of a single screw conveyor is shown in Figure 14. Based on the acceleration data from the ADAMS View Environment, the control system can be

developed. In many cases, maximum speed and acceleration are predominant characteristics of the machine tool component, which helps create proper driving mechanisms.

3.2. Deformation, Velocity, and Acceleration of Single Screw Conveyor (SSC) in ANSYS. The output result of ADAMS

View software is considered for the input speed of the conveyor machine in ANSYS. The screw is operated with the maximum speed of 3000 rpm, and its characteristic is analyzed. Figure 15 shows the total deformation of the conveyor screw; it was observed that during the rotary motion, the single screw conveyor tends to deform at a maximum range of 4.23 mm. Hence, the clearance between the barrel to the screw conveyor can be given above its maximum deformation value during its fabrication.

The total velocity outcome of a single screw conveyor analyzed from ANSYS is as shown in Figure 16. It shows the velocity of all the components combined by vectorial addition, and it has a maximum velocity of 42 m/s. The result is compared with the multibody dynamic analysis result value from ADAMS View, and it showed the lower value. Hence, the velocity of single screw conveyor will not create vibration to the machine tool component.

The total acceleration of a single screw conveyor analyzed from ANSYS is shown in Figure 17. It was observed that the maximum acceleration of 7.87 m/s^2 is obtained for a unit time. Hence, the acceleration value should be considered during the development of the driving mechanism for the single screw conveyor.

4. Conclusion

- (i) The multibody dynamic analysis results from ADAMS View shows the maximum displacement and velocity of the single screw conveyor. During the rotary motion, the conveyor screw tends to vibrate in the lateral and vertical axis direction. Hence, the conveyor machine should operate below its maximum velocity to avoid the resonance and stress created over the surface of the screw.
- (ii) The rigid body dynamic analysis result from the ANSYS workbench shows the velocity, deformation, and acceleration characteristics of a single screw conveyor. The velocity of the single screw conveyor creates less total displacement, so the clearance between the screw to the barrel should be appropriately maintained. The acceleration parameter needs to be considered during the development of the control/driving mechanism.

Data Availability

The data used to support the findings of this study are included within the article.

Conflicts of Interest

The authors declare that there are no conflicts of interest regarding the publication of this article.

Acknowledgments

Alagar Karthick gratefully acknowledges group FQM-383 from Universidad de Cordoba, Spain, for the provision of a honorary research position in the group.

References

- [1] V. V. Telegin, A. M. Kozlov, and V. I. Sakalo, "Solid modeling and dynamic analysis of mechanisms of press-forging machines," *Procedia Engineering*, vol. 206, pp. 1258–1263, 2017.
- [2] J. Zhang, R. Zhang, G. Ren, and X. Zhang, "A method for using solid modeling CAD software to create an implant library for the fabrication of a custom abutment," *The Journal of Prosthetic Dentistry*, vol. 117, no. 2, pp. 209–213, 2017.
- [3] M. F. Ahmad, H. Chun, N. Abdul Hamid et al., "The impact of product design and process design towards new product performance in manufacturing industry: a survey result in Malaysia," *International Journal of Supply Chain Management*, vol. 7, no. 2, pp. 102–105, 2018.
- [4] M. F. Ahmad, N. Zakuan, A. Jusoh, S. M. Yusof, J. Takala, and M. S. M. Arif, "Comparative study of TQM practices between Japanese and non-Japanese companies: proposed conceptual framework," *Advanced Materials Research*, vol. 903, pp. 371–377, 2014.
- [5] R. Ismail and I. Jajri, "Analisis perubahan kecekapan teknikal, perubahan teknologi, pertumbuhan produktiviti faktor keseluruhan dan pertumbuhan output dalam industri peralatan pengangkutan di Malaysia," *Jurnal Teknologi*, vol. 49, no. 1, pp. 31a–48, 2008.
- [6] X. Li, W. Zhao, Y. Zheng, R. Wang, and C. Wang, "Innovative product design based on comprehensive customer requirements of different cognitive levels," *TheScientificWorldJOURNAL*, vol. 2014, Article ID 627093, 2014.
- [7] J. Jiao and C.-H. Chen, "Customer requirement management in product development: a review of research issues," *Concurrent Engineering*, vol. 14, no. 3, pp. 173–185, 2006.
- [8] X. He, "Finite element analysis of laser welding: a state of art review," *Materials and Manufacturing Processes*, vol. 27, no. 12, pp. 1354–1365, 2012.
- [9] T. R. Lahari and G. Srinivas Sharma, "Parametric analysis of Single Screw extruder for processing of re-cycled plastics," *International Journal of Current Engineering and Technology*, vol. 12, no. 1, pp. 9–14, 2022.
- [10] A. C.-Y. Wang and L. W. Cisko, "Computer-aided design, analysis and optimization of mechanical press linkages," *MATERIAL AND MANUFACTURING PROCESS*, vol. 1, no. 3-4, pp. 455–471, 1986.
- [11] P. L. Tso and K. C. Liang, "A nine-bar linkage for mechanical forming presses," *International Journal of Machine Tools and Manufacture*, vol. 42, no. 1, pp. 139–145, 2002.
- [12] R. Singh, H. Singh, I. Farina, F. Colangelo, and F. Fraternali, "On the additive manufacturing of an energy storage device from recycled material," *Composites Part B: Engineering*, vol. 156, pp. 259–265, 2019.
- [13] H. F. Giles, E. M. Mount, and J. R. Wagner, *Extrusion: The Definitive Processing Guide and Handbook*, William Andrew, Norwich, NY, 2004.
- [14] D. Srinivasan, G. Veerappan, R. M et al., "Investigation on electric erosion behavior of nickel-based super alloy (Waspaloy: Ni, Cr, Co, Mo, Ti, Al) using response surface methodology," *Surface Topography: Metrology and Properties*, vol. 9, no. 3, Article ID 035006, 2021.
- [15] B. Stalin, M. Ravichandran, G. T. Sudha et al., "Effect of titanium diboride ceramic particles on mechanical and wear behaviour of Cu-10 wt% W alloy composites processed by P/ M route," *Vacuum*, vol. 184, Article ID 109895, 2021.
- [16] S. V. Alagarsamy, R. Balasundaram, R. M, V. Mohanavel, A. Karthick, and S. S. Devi, "Taguchi approach and decision tree algorithm for prediction of wear rate in zinc oxide-filled

- AA7075 matrix composites,” *Surface Topography: Metrology and Properties*, vol. 9, no. 3, Article ID 035005, 2021.
- [17] K. Yoganandam, V. Shanmugam, A. Vasudevan et al., “Investigation of dynamic, mechanical, and thermal properties of Calotropis procera particle-reinforced PLA biocomposites,” *Advances in Materials Science and Engineering*, vol. 2021, pp. 1–7, 2021.
- [18] T. Sathish, V. Mohanavel, A. Karthick, M. Arunkumar, M. Ravichandran, and S. Rajkumar, “Study on Compaction and machinability of silicon nitride (Si₃N₄) reinforced copper alloy composite through P/M route,” *International Journal of Polymer Science*, vol. 2021, pp. 1–10, 2021.
- [19] K. S. Ali, V. Mohanavel, M. Ravichandran, S. Arungalai Vendan, T. Sathish, and A. Karthick, “Microstructure and Mechanical properties of friction stir welded SiC/TiB₂ reinforced aluminum hybrid composites,” *Silicon*, pp. 1–11, 2021, In press.
- [20] P. Gurusamy, T. Sathish, V. Mohanavel et al., “Finite element analysis of temperature distribution and stress behavior of squeeze pressure composites,” *Advances in Materials Science and Engineering*, vol. 2021, pp. 1–9, 2021.