

Review Article

Review on Li-Ion Battery vs Nickel Metal Hydride Battery in EV

Vijayakumar Arun,¹ R. Kannan,² S. Ramesh,³ M. Vijayakumar,³ P. S. Raghavendran,⁴ M. Siva Ramkumar⁵, P. Anbarasu,⁶ and Venkatesa Prabhu Sundramurthy⁷

¹Department of EEE, Sree Vidyanikethan Engineering College, Tirupati, India

²Department of EEE, Erode Sengunthar Engineering College, Erode, India

³Department of EEE, K. S. R. College of Engineering, Tiruchengode, India

⁴Department of EEE, Kongu Engineering College, Perundurai, India

⁵Department of EEE, Karpagam Academy of Higher Education, Coimbatore, India

⁶Department of EEE, Sri Eshwar College of Engineering, Coimbatore, India

⁷Addis Ababa Science and Technology University, Addis Ababa, Ethiopia

Correspondence should be addressed to Venkatesa Prabhu Sundramurthy; venkatesa.prabhu@aastu.edu.et

Received 7 June 2022; Revised 10 July 2022; Accepted 20 July 2022; Published 18 August 2022

Academic Editor: Samson Jerold Samuel Chelladurai

Copyright © 2022 Vijayakumar Arun et al. This is an open access article distributed under the Creative Commons Attribution License, which permits unrestricted use, distribution, and reproduction in any medium, provided the original work is properly cited.

Currently, electric cars are receiving a lot of attention because of their low fuel consumption and pollution-free nature. The efficiency of electric vehicles is constantly being improved via a variety of studies and applications. The battery is a significant portion of an electric vehicle's overall component count. Because the electric vehicle's battery acts like the vehicle's heart, battery performance and efficiency in electric vehicles (EVs) are examined in this research.

1. Introduction

Although electrification has become the industry's growth trend, current isolation is becoming more important to enable computerized controllers to be safely coupled to new electric cars' high-voltage systems [1]. Isolation devices are also covered in this article, which focuses on the fundamental advances in electric vehicle design.

2. Electric Vehicle Types

Electric cars (EVs), hybrids, and 48 V mild hybrids are all on the horizon for major manufacturers, which have all stated their intention to produce new models (MHEV). Use of 48 V MHEV systems to power up engine subsystems on conventional internal combustion engines is rising in the double rates (ICE) [2]. The cheap cost and convenience, with which existing transmission systems may be adapted for the 48 V mild hybrid architecture, will increase demand for power circuits in automotive applications.

2.1. Battery Electric Vehicles (BEVs). Another moniker for a BEV is an all-electric vehicle (AEV). Battery-powered electric vehicles (BEVs) have no internal combustion engine. In order to recharge the vehicle's battery pack, it must be plugged into the power grid. The battery pack is then used to power one or maybe more electric motors, which in turn power the electric vehicle.

2.2. Main Components of BEVs. A BEV consists of an electric motor, an inverter, a battery, and a control module.

2.2.1. Working Principles of BEVs. The electrical motor is driven by converting DC power to AC power in a BEV. While driving, pressing the accelerator results in data being sent to the vehicle's control system. To manage the vehicle's speed, the controller modifies the inverter's AC power frequency [3]. Wheels turn as a result of the motor's connection with a gear. So when brakes are engaged or the electric vehicle slows, the motor converts to that of an alternator and generates electricity that is returned to the battery.

2.2.2. *Examples of BEVs.* The following are the examples of BEVs: Toyota RAV4, Toyota RAV4, Mahindra E20 plus, Mahindra Verito, and TATA Nexon.

2.3. *HEV.* Hybrid electric vehicles (HEVs) are sometimes known as series hybrids or parallel hybrids. Both an internal combustion engine and an electric motor are used in hybrid electric vehicles (HEVs) as shown in Figure 1. The engine runs on fuel, while the battery powers the motor [4].

2.3.1. *Components of an HEV.* The components of an HEV are a battery pack, a gasoline tank, and a control with inverter batteries.

2.3.2. *Operating Principles of HEVs.* The fuel tank, as much as in a standard automobile, delivers power to the engine. Powered by an electric motor, the batteries are recharged [5]. The gearbox may be rotated simultaneously by both the motor and the electric motor.

2.3.3. *Examples of HEVs.* The examples of HEVs are electric motors and engines, inverters and controllers for a battery pack, a tank of fuel, and a module of control.

2.4. *Plug-In Hybrid Electric Vehicle (PHEV).* PHEVs might be referred to as series hybrids. They are equipped with both a motor and a combustion engine as shown in Figure 2. Alternative fuels may be used in place of traditional fuels (such as gasoline) (such as biodiesel) [6]. They may also be powered by a rechargeable battery pack. It is possible to charge the battery outside.

PHEVs can run in at least 2 modes:

- (i) An electric mode, where the motor-combined batteries provide all of the car's power, is the most common mode.
- (ii) A hybrid mode makes use of both electric power and gasoline or diesel power.

2.4.1. *Main Components of a PHEV.* A PHEV's primary components are an electric motor, an internal combustion engine, a battery, a gasoline tank, a control module, and a battery charger (if onboard model).

Principles of operation of PHEVs are as follows.

Prius plug-in hybrid vehicles are designed to operate solely on the power of their battery pack. A nonplug-in hybrid vehicle switches to its engine when its battery runs low. There are a number of ways to charge PHEVs, including utilising the engine, regenerative braking, or plugging in an additional electric power source [7]. Brakes activate the electric motor's generator mode, which uses kinetic energy to charge a battery. It is possible to employ smaller engines while still achieving the same performance levels thanks to the electric motor's ability to augment the engine's power output.

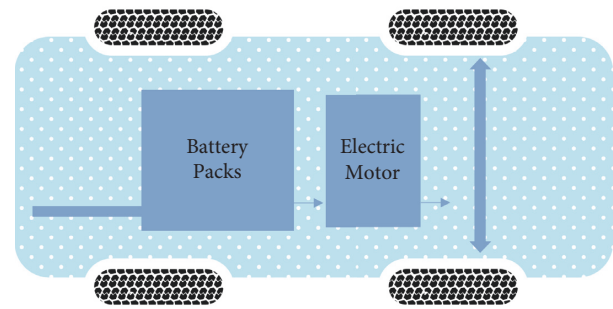

FIGURE 1: HEV car representation.

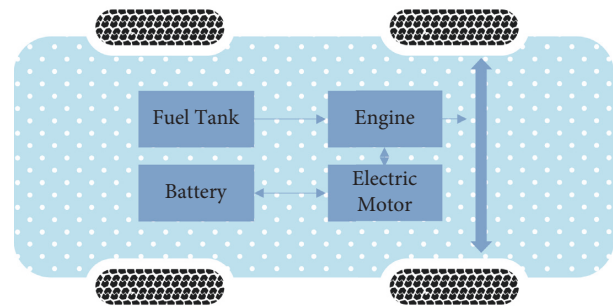

FIGURE 2: PHEV car representation.

2.4.2. *Examples of PHEVs.* All of these cars are hybrids: Porsche Cayenne S E-Hybrid, BMW 330 e, Porsche Panamera S E-hybrid (with a regenerative braking system), Chevy Volt, Chrysler Pacifica, Ford C-Max Energi, Mercedes C350 e, and Audi A3 E-Tron.

2.5. *Fuel Cell Electric Vehicle (FCEV).* FCEVs are also known as zero-emission vehicles as shown in Figure 3. "Fuel cell technology" is used to generate the energy required to power the vehicle [8]. Chemical energy in the fuel is quickly converted to electrical energy in the generator [9]. More information on FCEVs as follows.

2.5.1. *Components of FCEVs*

Storage of hydrogen in a fuel cell stack and a battery with a converter and controller

Principles of FCEVs

The FCEV creates the electricity needed to power the vehicle

2.5.2. *Examples of FCEVs.* The following are the examples of FCEVs: Riversimple Rasa, Hyundai Tucson FCEV, Honda Clarity fuel cell, and Hyundai Nexa.

3. Batteries

In electric cars, the battery storage system is provided by a battery, as shown in Figure 4. All-electric (AEV) and hybrid electric (PHEV) vehicles have several battery types (PHEV). Battery technology nowadays is designed to last a long

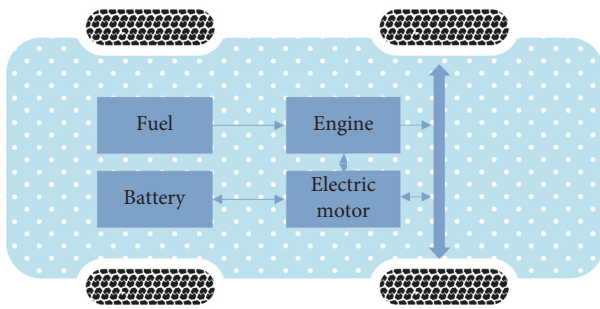

FIGURE 3: FCEV car representation.

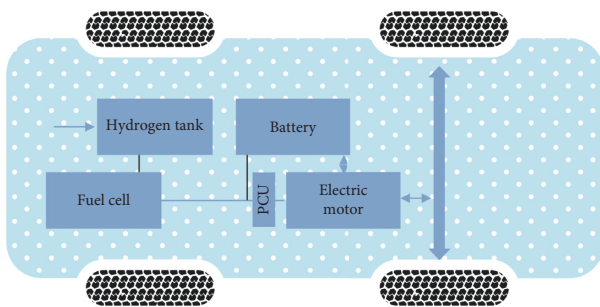

FIGURE 4: HFCEV car representation.

period. Depending on the location, some batteries may survive 10–15 years, whereas others last 8 to twelve years under harsh conditions [10]. The four basic battery types in electric cars are rechargeable batteries, lithium hydride, lead-acid, and ultracapacitors.

3.1. Car Batteries' Working. All-electric cars employ electric traction motors instead of gasoline-powered vehicles' internal combustion engines. A traction battery pack (usually a lithium-ion battery) is used to store the power needed by the motor to move the vehicle's wheels [11]. The vehicle's entire range is influenced by the efficiency of the traction battery pack, which must be connected to a power source and refilled.

Like AEVs, plug-in hybrids have traction battery packs that power their electric motors. The key difference would be that the battery also has a combustion engine. When the battery in a plug-in hybrid electric vehicle becomes low, it switches to a conventional internal combustion engine fuelled by gasoline [12]. Recharging the lithium-ion battery is as simple as plugging it in, turning on regenerative braking, or firing up the car's engine. A PHEV's battery and gasoline combination gives it a greater range than an all-electric car.

4. Types of Batteries in EVs

4.1. EV Types of Batteries. These batteries may be charged again and again. For electric cars, lithium-ion batteries are the most common [13].

There are many portable electronic devices that utilise this sort of battery, such as mobile phones or personal

computers, and that may sound familiar. Lithium-ion batteries provide a high power-to-weight ratio and outstanding high-temperature performance [14]. For electric cars, this means that the batteries could store a huge amount of energy given their cost, which is critical since lighter vehicles can go longer on a single charge. It is also worth noting that lithium-ion batteries maintain their tendency to hold a recharge longer than conventional batteries because of their low "self-discharge" rate [15]. Aside from being reusable, lithium-ion battery components are ecologically beneficial. AEVs and PHEVs use the same battery, although bio-chemistry is different from those found in consumer electronics.

4.2. Batteries with Nickel-Metal Hydride. Hybrid cars tend to use nickel-metal hydride batteries more than all-electric cars, although both may use them. Hybrid-electric cars are not categorised as electric vehicles since they do not use a plug-in source of power and instead recharge the battery using gasoline.

By comparing lithium and lead acid batteries, the battery charging time and lifetime are better in lithium than the lead acid battery [16]. Abuse is tolerated, yet they are also a safe place to be. The main drawbacks of nickel-metal hydride batteries are their high cost, strong self-rate, and the fact that they produce a large amount of heat at extreme temperature. Hybrid electric cars, but instead of rechargeable electric vehicles, often utilise these batteries because of the challenges they provide.

4.3. Lithium-Ion Batteries. Now, lead-acid battery packs are utilised to supplement other battery packs in electric cars. These batteries' short annual life and poor cold temperature performance make it difficult to use them in electric cars despite their high power, low cost, safety, and reliability [17]. They are being developed but only in commercial vehicles, such as high capacity lead-acid batteries that can store a large amount of energy.

4.4. Ultracapacitors. Ultracapacitors are not batteries in the traditional sense. Instead, they store polarised liquid in an anode and an electrolyte. As a liquid's surface area increases, so does its energy-storing ability. Ultracapacitors, like lead-acid batteries, are often utilised as supplementary disk drives in electric automobiles because they help electrochemical batteries balance their load [18]. During accelerating and regenerative braking, ultracapacitors may provide additional power to electric cars.

4.5. Nickel-Metal Hydride Battery. Rechargeable nickel-metal hydride batteries (also known as NiMH or Ni-MH batteries) are among the finest in the market. Using nickel oxide hydroxide, they generate the best chemical reaction, which is similar to that of metals cell (NiCd) (NiOOH) [19]. They use a hydrogen-absorbing alloy for negative electrodes instead of cadmium. Approximately twice the volume of

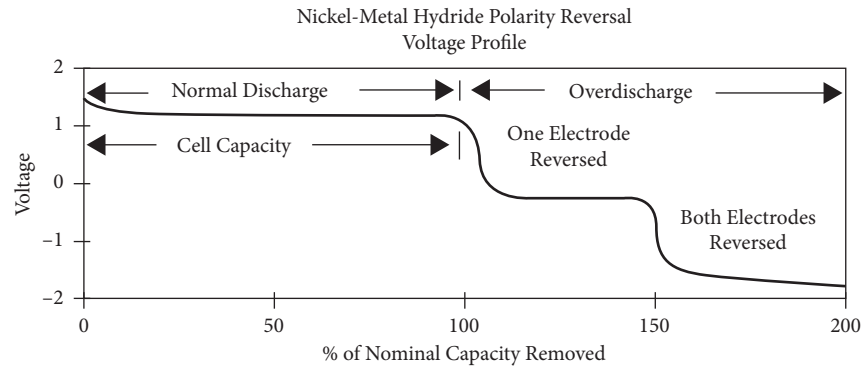

FIGURE 5: Ni-metal polarity reversal voltage profile.

NiCd batteries and much superior energy efficiency to lithium-ion batteries may be found in NiMH batteries.

A constant voltage charging is old and basic method of charging a battery for a longlasting performance. When the current rate is as low as $0.1C$ ($C/10$), the majority of manufacturers claim that overcharging is not an issue. Even if you do not overcharge your battery, Panasonic's NiMH charging guidelines suggest limiting the overall charging period to 10 to 20 hours.

For batteries that need to be maintained fully charged, Duracell suggests using a trickling charging at $C/300$ [20]. A few chargers compensate for excessive self-discharge by doing so well after the charge cycle.

Gas develops on the electrodes when charging costs more than $C/10$. So the cell becomes heated because of this reason. A $C/30$ or $C/40$ rating is recommended by the manufacturer for long-term storage packaging. To meet an urgent need for lighting fixtures, this approach is employed with a trickle-charging resistor that costs less than previous NiCd devices [21]. For NiMH batteries in standby, Panasonic recommends charging them using a reduced responsibility cycle approach and applying a more modern pulse if the battery voltage drops below 1.3 V. Therefore, you will be able to get more life out of your batteries and save money on your energy bill.

4.6. Discharge. In Figure 5, the $C/10$ charge pattern at 25°C , you can observe how the discharging graph of a NiMH battery varies with the discharge rate and temperature [22]. As soon as 1.5 volts of a full battery is removed, the voltage rapidly lowers to 1.3 volts.

4.7. Overdischarge. One or maybe more cells in a multicell pack might be damaged permanently if they are discharged completely. The earlier setup of four AA Battery for a camcorder, the 1st cell in the setup will drain out soon wherein rest 3 battery with charge. However, in the case of lithium, it would not happen [23]. As a result, the positive anode and negative cathode polarity of the good cells is reversed. In certain photos, GPS receivers, or PDAs, the safe end-of-discharge voltage of series cells is detected and switched off automatically, but flashlights and some toys are not.

4.8. Self-Discharge. For a while, there was a charge-discharge rating on NiMH batteries. Internal leakage is nearly comparable to this. As a part of the discharge process, temperature is an important consideration [24]. The discharging process is accelerated, and the battery's life expectancy is extended when the temperature is low. There is a 5 to 20 percent chance of self-charging at room temperature.

4.9. Nickel-Metal Hydride Battery for Electric Vehicles. In Figure 6, NiMH batteries were often used in earlier generations of electric and hybrid vehicles because they provided a number of advantages compared to lead-acid batteries. This is due to the NiMH battery's superior long-term performance as well as its lower overall cost and safety [25]. Most electric or plug-in hybrid cars now employ NiMH batteries including the Vector shooter, Ford Ranger EV, General Motors EV1, and the Honda Electric Vehicle Plus.

4.10. Lithium-Ion Electric Car Battery. Rechargeable lithium-ion (Li-ion) packs are widely used in electric cars and a wide range of portable electronic devices. As a result, they have a greater energy density than more traditional rechargeable batteries like lead-acid or nickel-cadmium. As a consequence, battery packs may be made smaller and more compact.

This metal is the lightest of them all. Lithium batteries containing lithium ions, rather than lithium metal, are called lithium-ion (Li-ion) batteries [26]. When an ion loses or gains one or more electrons, it acquires an electric charge, which is known as an ion's electric charge.

Lithium-ion batteries also are healthier than most other alternatives, and battery manufacturers must guarantee that customers are covered in the event of a battery failure [27]. In electric cars, for example, manufacturers add charging protections to protect batteries against repeated fast charging sessions over a short time span.

5. Lithium-Ion vs Nickel-Metal Hydride Batteries

In practice, there are several differences between various structures:

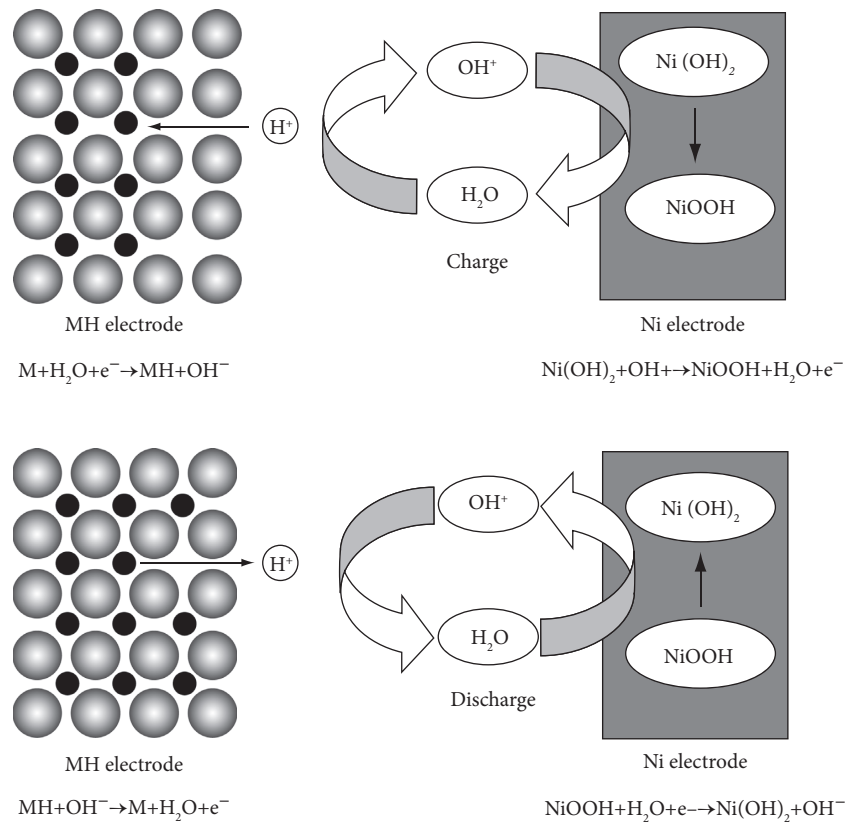

FIGURE 6: NiMH batteries.

NiMH batteries are also the least expensive option available right now. In the future, as the manufacturing process of lithium-ion cells develops, efficiencies will reduce the cost of these cells. As more cars demand more batteries, the cost of manufacturing each battery drops.

NiMH batteries are heavier and bulkier than Li-ion batteries. To get the most mileage out of a hybrid car, its battery can overcome a vehicle's inertia on its own (without the help of a gasoline engine). In order to easily start the automobile, more energy dense battery packs are used.

In terms of energy storage capacity, both lithium-ion and nickel-metal hydride batteries are comparable; however, lithium-ion batteries are charged and discharged more quickly, while the "memory effect" occurs when batteries are charged before they are entirely exhausted, and Li-ion batteries have less of this issue [28]. A battery's capacity may be reduced by doing this. The memory effect is less of an issue with lithium-ion batteries than with NiMH batteries (Hitachi is the source for this information).

Although both NiMH and lithium batteries are long-lasting batteries and are being used in a wide range of devices for many years, NiMH has the edge when it comes to durability. Some Li-ion batteries, especially in hot areas, may not last as long under severe temperatures [29]. Manufacturers, on the other hand,

are working to improve the composition of Li-ion cells so that they can power cars for as long as possible.

6. Features of the Li-Ion Battery

Other sophisticated battery and supercapacitors will only challenge a tiny portion of the lithium-ion battery market even in 2030, when it is already clear that the lithium-ion battery is the clear winner.

From 2020 to 2030, the majority of electric cars will be powered by lithium-ion batteries (LIBs). Their effectiveness, affordability, mass, and size are virtually always the best in a wide range of applications [30]. Nevertheless, there are also some surprises to be found when doing a comprehensive, fact-based study. Over \$3 billion is spent on electric vehicles in 2030, but autos are losing market share, and demand for battery packs considerably smaller and bigger than that used in automobiles is growing.

It is shown in the article that current Gigafactory claims are grossly unable to supply this demand in just a few years, assuming unconstrained supplies and competitive rates. In addition, there are considerable regional differences in demand and supply, as well as widely differing average automotive battery capacity.

It is expected that either the battery or the pack would be in high demand. On top of all this, engineers are working hard to reduce the battery's cost burden, which now

TABLE 1: Comparison of Li-ion vs Ni-MH.

S. no	Specifications	Li-ion	NiMH
1	Energy	160	90
2	Voltage	3.6 V	1.2 V
3	Size and capacities	Customized and 2000–6000 mAh	3XAA and 2000 mAh
4	Self-discharge rate per month	2–8%	30–50%
5	Price range (depends on battery type)	30 to 500\$	20–150\$
6	Maintenance	No	Low

accounts for as much as one-third of the whole car cost [31]. The report of a scientific study, not an advocate for the industry, notes possible shortages of materials and other obstacles. This is because it is an analysis.

If we want to achieve higher energy density without lowering cell prices, IDTechEx argues, we cannot just keep introducing more costly materials.

Two of the most rapidly developing sectors of the business are examined in this paper: cell biology and thermal management.

Since cell chemistry is improving and allowing for greater energy densities, cerium NMC 811 is the newest and most noteworthy cathode iteration to reach the road. Lithium ion and solid-state batteries, on the other hand, are fast making their way into mainstream commercial use. By comparing the lithium and lead acid batteries, the lithium battery has a fast charging technology.

There seems to be no agreement on the best way to regulate the temperature of a pack. Air, liquid, and refrigerant-cooled technologies are being pursued by a number of high-profile companies.

In the marketplace of electrode materials, new technologies like absorption cooling, phase-change material encasings, and tab cooling are also gaining popularity and gaining ground [32]. As a result of recent high-profile thermal runaway incidents, the regulatory environment is shifting.

Finally, this study explores the possibilities of lithium-ion batteries after a vehicle's useful life. There are a wide range of uses for this, including charging stations to low-speed vehicles. A comparison of batteries is shown in Table 1.

7. Conclusion

Lithium-ion and nickel-metal hydride batteries are the focus of this research. There are a variety of advantages and disadvantages to each battery. Research will also increase efficiency and minimise demerits owing to preventing undesired harm and blend the advantages of both batteries to make an efficient one. In order to increase the EV's transportation capacity and battery charging speed, it will need effective energy storage devices. As soon as all of the conditions have been met, electric vehicles may be used by the general public for the first time.

Data Availability

The data used to support the findings of this study are included within the article.

Conflicts of Interest

The authors declare that they have no conflicts of interest.

References

- [1] S. Manzetti and F. Mariasiu, "Electric vehicle battery technologies: from present state to future systems," *Renewable and Sustainable Energy Reviews*, vol. 51, pp. 1004–1012, 2015.
- [2] 2017 Howell, *EV Obsession 2015 and Cobb*, China, 2015.
- [3] J. Beier, B. Neef, S. Thiede, and C. Herrmann, "Integrating on-site renewable electricity generation into a manufacturing system with intermittent battery storage from electric vehicles," *Procedia CIRP*, vol. 48, pp. 483–488, 2016.
- [4] M. B. Smith and J. Castellano, *Costs associated with non-residential electric vehicle supply equipment*, U.S. Department of Energy, Atlanta, Bost, 2015.
- [5] J. Clint, B. Gamboa, B. Henzie, and A. Karasawa, *Considerations for Corridor Direct Current Fast Charging Infrastructure in California*, California, 2015.
- [6] G. Meng and M. Patrick, "Securing android app markets via modelling and predicting malware spread between markets," *IEEE Trans. Inf. Forensics Security*, vol. 14, 2018.
- [7] T. Mesbahi, N. Rizoug, and P. Bartholome, "Dynamic model of Li-ion batteries incorporating electrothermal and ageing aspects for electric vehicle applications," *IEEE Transactions on Industrial Electronics*, vol. 65, 2018.
- [8] S. Narain and T. VoHuu, "Inferring user routes and locations using zero-permission mobile sensors," *Proceedings of SPIE*, vol. 1, 2016.
- [9] C. Niddodi and S. Lin, "Secure Integration of Electric Vehicles with the Power Grid," 2019, <https://www.arxiv-vanity.com/papers/1905.01035/>.
- [10] A. F. Burke, "Batteries and ultracapacitors for electric, hybrid, and fuel cell vehicles," *Proceedings of the IEEE*, vol. 95, no. 4, pp. 806–820, 2007.
- [11] F. Feng and D. Northwood, "Self-discharge characteristics of a metal hydride electrode for Ni-mh rechargeable batteries," *International Journal of Hydrogen Energy*, vol. 30, no. 12, pp. 1367–1370, 2005.
- [12] W. Kim, M. Kang, and S. Young, "Vehicle Path Prediction Using Yaw Acceleration for Adaptive Cruise Control," *IEEE Trans. on ITS*, vol. 12, 2018.
- [13] Y. Kim, T. Schmid, and Z. M. Charbiwala, "ViridiScope: design and implementation of a fine grained power monitoring system for homes," *Proc. of Ubicomp*, vol. 1, 2009.
- [14] R. C. Leou and J. H. Teng, "Stochastic Analysis of Electric Transportation Charging Impacts on Power Quality of Distribution Systems," *IET GENER TRANSM DIS*, vol. 29, 2018.
- [15] I. D. Taesic Kim, A. A. DarshanMakwana, J. S. Vagdoda, and Y. Lee, "Cloud-Based Battery Condition Monitoring and Fault Diagnosis Platform for Large-Scale Lithium-Ion Battery

- Energy Storage Systems,” *Paper Published at Energies*, Kingsville, TX 78363, USA, 2017.
- [16] A. Z. Muhammad Umair Ali, S. H. SarvarHussainNengroo, M. JunaidAlvi, and H. Je Kim, “Towards a Smarter Battery Management System for Electric Vehicle Applications,” *A Critical Review of LithiumIon Battery State of Charge Estimation*, USA, 2019.
- [17] H. S. Bhattacharyya, A. B. Choudhury, and C. Kumar Chanda, “Performance analysis of a lithium-ion battery pack in EV application using an auto-upgraded neural network model,” in *Proceedings of the 2019 8th International Conference on Power Systems (ICPS)*, pp. 1–6, aipur, India, October 2019.
- [18] World Energy Council, *World Energy Council Resources, E-Storage: Shifting from Cost to Value*, Wind and solar applications, Thiruvanniyur, Chennai, 2016.
- [19] C. M. Julien and G. Pistoia, *Lithium Batteries: Science and Technology, Lithium Batteries*, pp. 29–68, Springer, Heidelberg, Germany, 2016.
- [20] F. Feng, X. Hu, J. Liu, X. Lin, and b. Liu, “A review of equalization strategies for series battery packs: variables, objectives, and algorithms,” *Renewable and Sustainable Energy Reviews*, vol. 116, p. 109464, 2019.
- [21] P. Pathiyil, K. Sibi Krishnan, R. Sunitha, and V. N. Vishal, “Battery model for Hybrid Electric Vehicle corrected for self-discharge and internal resistance,” in *Proceedings of the 2016 2nd International Conference on Advances in Electrical, Electronics, Information, Communication and Bio-Informatics (AEEICB)*, pp. 214–218, Chennai, July 2016.
- [22] M. S. Chitnis, S. P. Pandit, and M. N. Shaikh, “Electric vehicle Li-ion battery state of charge estimation using artificial neural network,” in *Proceedings of the 2018 International Conference on Inventive Research in Computing Applications (ICIRCA)*, pp. 992–995, Coimbatore, June 2018.
- [23] K. Sarrafan, K. M. Muttaqi, D. Sutanto, and G. E. Town, “A real-time range indicator for EVs using web-based environmental data and sensorless estimation of regenerative braking power,” *IEEE Transactions on Vehicular Technology*, vol. 67, no. 6, pp. 4743–4756, 2018.
- [24] K. Vatanparvar, S. Faezi, I. Burago, M. Levorato, and M. A. Al Faruque, “Extended range electric vehicle with driving behavior estimation in energy management,” *IEEE Transactions on Smart Grid*, vol. 10, no. 3, pp. 2959–2968, 2019.
- [25] S. Barcellona, D. D. Simone, and S. Grillo, “Real-time electric vehicle range estimation based on a lithium-ion battery model,” in *Proceedings of the 2019 International Conference on Clean Electrical Power (ICCEP)*, pp. 351–357, Otranto, Italy, June 2019.
- [26] Y. Cao, R. C. Kroeze, and P. T. Krein, “Multi-timescale parametric electrical battery model for use in dynamic electric vehicle simulations,” *IEEE Transactions on Transportation Electrification*, vol. 2, no. 4, pp. 432–442, 2016.
- [27] D. Baek and N. Chang, “Runtime power management of battery electric vehicles for extended range with consideration of driving time,” *IEEE Transactions on Very Large Scale Integration Systems*, vol. 27, no. 3, pp. 549–559, 2019.
- [28] C. Kurien and A. K. Srivastava, “Impact of electric vehicles on indirect carbon emissions and the role of engine posttreatment emission control strategies,” *Integrated Environmental Assessment and Management*, vol. 16, no. 2, pp. 234–244, 2020.
- [29] N. O. Kapustin and D. A. Grushevenko, “Long-term electric vehicles outlook and their potential impact on electric grid,” *Energy Policy*, vol. 137, Article ID 111103, 2020.
- [30] J. Duan, X. Tang, H. Dai et al., “Building safe lithium-ion batteries for electric vehicles: a review,” *Electrochemical Energy Reviews*, vol. 3, no. 1, pp. 1–42, 2019.
- [31] Y. e. Ekici, N. Tan, and Y. E. Ekici, “Charge and discharge characteristics of different types of batteries on a hybrid electric vehicle model and selection of suitable battery type for electric vehicles,” *International Journal of Automotive Science And Technology*, vol. 3, no. 4, pp. 62–70, 2020.
- [32] H. S. Chen, “Overview of cell balancing methods for Li-ion battery technology,” *Energy Storage*, vol. 3, no. 2, p. e203, 2021.