

Research Article

The Role of Employee Demographic Characteristics and Selection of Human Resource Management Methods on Organizational Tensions and Turnover Intention

Bahman Saeidipour ¹, Peyman Akbari ², and Zahra Alizadeh ¹

¹Department of Educational Management, Payame Noor University, Tehran, Iran

²Department of Public Management, Payame Noor University, Tehran, Iran

Correspondence should be addressed to Zahra Alizadeh; alizadehzahra094@gmail.com

Received 25 November 2021; Revised 17 April 2022; Accepted 13 June 2022; Published 2 August 2022

Academic Editor: Gwo-Jen Hwang

Copyright © 2022 Bahman Saeidipour et al. This is an open access article distributed under the Creative Commons Attribution License, which permits unrestricted use, distribution, and reproduction in any medium, provided the original work is properly cited.

Aim. The purpose of this study was to investigate the role of demographic characteristics of employees and the selection of human resource management methods on organizational tensions and turnover intention. **Methodology.** This study is applied in terms of purpose and descriptive survey in terms of nature and method. The statistical population of this study includes 380 employees (scientific and administrative) of Payame Noor University of Kermanshah Province, which uses Cochran's formula, and 191 people were selected as a sample. Data collection tools were questionnaire. **Results.** The results of testing the hypotheses by SMARTPLS software and using *t*-test statistics and path coefficients (β) showed that the demographic characteristics of employees on the selection of human resource management methods, organizational tensions, and layoffs have a strong, direct and significant effect, a moderate, direct and indirect and significant effect, and a moderate, direct and indirect and significant effect, respectively. The choice of human resource management methods has moderate, direct, and significant effects on organizational tensions and turnover intention, and a weak, direct and ultimately indirect, and significant effect, respectively. Also, organizational tensions have a moderate, direct, and significant effect on turnover intention. On the other hand, the choice of human resource management methods can play a mediating role in influencing the demographic characteristics of employees on organizational tensions and turnover intention goals. Also, organizational tensions can play a role as a mediating variable in influencing the demographic characteristics of employees and the choice of human resource management methods on the purposes of turnover intention. **Conclusion.** According to the findings of the study, it should be said that the relevant university to reduce the organization's stress and intentions to turnover intention must resort to appropriate methods of human resource management. Of course, in this way, university administrators can use the cognitive characteristics of employees to choose the best management method.

1. Introduction

To be successful in an organization, financial tools and human resources must be put together to increase overall productivity, which is the success of the organization. Organizational success actually refers to the achievement of organizational goals and vision in a specific time frame. This study focuses on human resource management. Therefore, organizations must make binding investments

in relation to employee rewards and training, which are essential to achieving the expected results. In this case, the loss of an employee is a direct loss to the organization, which includes the cost and time spent hiring a new employee during the replacement. Thus, according to research by Khilji and Wang [1], motivated employees remain strong in their current organization. Therefore, employees need to be motivated to stay in the current organization. Numerous studies have been conducted on the factors that

affect human resources and employee retention in various industries. Michel et al. [2] conducted a study to investigate the impact of different human resource methods on organizational commitment of employees in the Kuwaiti banking sector. The results showed that fifty percent of the variables confirmed previous studies and the remaining fifty percent did not support studies due to factors such as culture and value. Also, Komal and Samina [3] conducted a research study to investigate the impact of employee participation, job satisfaction, clarity of role, and organizational space on organizational commitment of employees in various banking industry organizations in Islamabad, both in the public and private sectors. The results of the study showed that in addition to the four variables considered and effective in organizational commitment, there are other variables. They also believe that job satisfaction plays an imminent role in commitment to the organization and work. Based on what has been said, the purpose of this study was to investigate the role of demographic characteristics of employees and the selection of human resource management methods on organizational tensions and turnover intention. The employee's purpose for thinking about leaving the job comes from other employees. As a result, there is a plan to leave the job, and as a result, the search for an alternative job is done, and finally, the tendency to leave the current job will increase and more organizational tensions will cause the job to leave. Therefore, the management of the organization must choose the right methods of human resource management.

Also, Komal and Samina [3] showed that employee participation, job satisfaction, role clarity, and organizational climate affect employee organizational commitment. They also believe that job satisfaction plays an imminent role in commitment to the organization and work. According to what has been said, the purpose of this study was to investigate the role of demographic characteristics of employees and the selection of human resource management methods on organizational tensions and turnover intention. According to the above definitions and recent developments at Payame Noor University in the field of human resources and strategy, one of the factors that causes the failure of these developments and their efficiency is the wrong choice of human resource management methods. Therefore, by identifying the effects of proper human resource management methods, the necessary decisions can be made to reduce organizational tensions and turnover intention. Practically, this research helps a lot in drafting the current organizational statutes in educational organizations and increases the practical commitment and interest of employees in their job performance and work outcome. In general, organizational improvement is a very broad process in which factors such as human resource management methods are of great importance. Therefore, the main question of the research is as follows: does the role of demographic characteristics of employees and the choice of human resource management methods affect organizational tensions and turnover intention?

2. Research Literature: Job Leaving, Demographic Effects, Choice of Human Resource Management Practices, and Organizational Stress

Turnover intention, in various ways, affects the dynamics of the workforce within the organization and the ultimate destiny of an organization. According to Stallworth, turnover intention costs a lot for the organization because most organizations spend a lot of money in the areas of selection, training, and development of human resources to achieve efficient and effective human resources. Turnover intention, in general, reflects the employees' interest in looking for alternative jobs and leaving the organization. Today, the turnover intention is one of the biggest challenges in all organizations, regardless of the type of organization. Experts in economics and human resource management believe that the cost of turnover intention of skilled and specialized staff for the organization is high and even, in some cases, irreparable. Employee dismissal costs, depending on the efficiency of each employee, cause damage to the organization of between 25 and 200% per year. In addition, the spiritual losses caused by turnover intention, such as loss of experience and reduced enjoyment of collective wisdom, as well as reduced commitment, motivation, and work ethic among the remaining employees, are among the things that cannot be measured. Other costs associated with turnover intention include the costs of recruiting and reusing people, selecting and training them, reducing efficiency until a replacement person enters the organization and becomes skilled, and spending time and credit to compensate for shortcomings. Therefore, identifying the factors affecting employee layoffs in terms of demographics, methods of promotion (selection of human resource management methods), and organizational stress (organizational stress) is very basic and important for organizations. Therefore, it can be said that human resources are a valuable asset to any organization. By choosing the best management method to manage them, not only can steps be taken to reduce organizational stress, but they can also help to reduce job losses. Of course, paying attention to the demographic principles of employees can be a great help in choosing management practices and reducing organizational stress and ultimately reducing layoffs [4]. Based on the above, it can be said that much research has been done on the research variables, which we remember some of. Ebrahimi Nejad et al. [5] studied the relationship between organizational tension variables and turnover intention. Their results showed that the stress caused by inappropriate organizational structure has a positive effect on the turnover intention. Their results also showed that stress due to wage fluctuations and stress due to job insecurity are factors affecting the willingness of employees to turnover intention. However, the stress caused by the introduction of new technology in the organization, as well as the stress caused by unfavorable working conditions, respectively, is the least effective factor compared with other factors in the turnover intention in government organizations. Kanaani [6] addressed the effect that human resource management

measures can have on the tendency of employees to turnover intention in small and medium businesses. The results of data analysis showed that there is a significant negative relationship between training, service and benefit compensation, performance management, job development, and employee relationship with the desire to turnover intention. Zahedi et al. [7] designed a model for selecting and implementing organizational resource planning systems in government organizations. The globalization of competition between organizations and companies to offer their products and services has forced them to join global markets. One of the important tools of information and communication technology that plays an important role in the integration of information in the organization and is one of the main conditions for joining global markets is enterprise resource planning (ERP) systems. This system is currently considered as the newest and most effective tool for planning the total resources of the organization and includes a system of all-inclusive information, engineering, and management that meet all the needs of an organization with a process approach (operations) satisfies. Rangriz and Mahzabi [8] examined the role of human resource management measures and the tendency to leave the organization, considering the mediating role of psychological contract violations. Their results showed that human resource management measures and their dimensions have a negative effect on psychological contract violations. Also, the impact of human resource management measures and their dimensions on the turnover intention was negative. The critical value of the indirect effect between human resource management measures and the turnover intention through the mediating variable of psychological contract violation is equal to 2.10. In other words, the violation of the psychological contract, as a mediating variable, plays a role in the effect of the above two variables. Akbari and Ali Akbari [9] examined the effect of demographic characteristics of employees and the selection of human resource management methods on the purposes of turnover intention. Their results showed that payment method, procedural justice, marital status, education, work experience, and job position are important factors in determining the goals of leaving the employee. Edgar and Geare [10] examined the effect of employee demographic characteristics on the choice of human resource management methods. The results of this study showed that the demographic characteristics of employees will be able to influence the choice of human resource management methods. Ikhlas and Al-Kilani [11] in a study examined the effect of choosing human resource management methods on reducing turnover intention. They concluded that the choice of human resource management methods has an effect on reducing turnover intention. Gadi and Kee [12] in a study examined the effect of choosing human resource management methods on reducing turnover intention, considering the mediating role of perceived organizational support. They concluded that the choice of human resource management methods has an effect on reducing turnover intention, and this effect will be greater given the mediating role of perceived organizational support. Agyeman and Ponniah [13] in their study examined the role of demographic

characteristics of employees in reducing turnover intention and employee survival. Their results showed that the demographic characteristics of employees are effective in reducing turnover intention and the survival of employees. Likoko et al. [14] in their research examined the role of demographic characteristics of employees in reducing turnover intention. The results showed that the demographic characteristics of employees are effective in reducing turnover intention. Demir and Uyargil [15] examined the relationship between employee demographic characteristics and the choice of human resource management methods. Their results showed that the demographic characteristics of employees and the choice of human resource management methods have a significant relationship with each other. Hassani et al. [16] examined the effect of the role of employee demographic characteristics on organizational conflict as an example of organizational tensions. The results of this study showed that the demographic characteristics of employees have an effect on organizational conflict as an example of organizational tensions. Darty [17] addressed the effect of the role of employee demographic characteristics on work-family conflict as an example of organizational tensions and job satisfaction. The results of this study showed that the demographic characteristics of employees have an effect on organizational conflict as an example of organizational tensions, but work-family conflict has a negative effect on job satisfaction.

According to what has been said, the conceptual model of the research has been compiled according to Figure 1. This pattern reflects the effects that have occurred between the research variables.

3. Research Method

This research is “applied research” in terms of purpose and “descriptive survey research” in terms of how to collect data. Because researchers seek to determine the relationship between research variables, this research is of the “correlational research” type. The statistical population in this study, according to the research variables, were all employees of Payame Noor University of Kermanshah Province, whose number was 380 people. The sample size was 191 people obtained through the Morgan table, and the selection of individuals was simply random. The questionnaire on demographic characteristics of employees, human resource management methods, and organizational tensions, which consists of 25 questions, and the Saeedipour and Akbari’s questionnaire of intentions (2018), which consists of 3 questions, was used as the main data collection tools. The measurement tool was based on Likert’s five-choice range, starting with “strongly disagree” and ending with “strongly agree.” The scoring method of the questions is also calculated from a score of 1 to a score of 5. To confirm the validity of the measurement tool, three types of evaluation validity have been used, namely content validity, convergent validity, and divergent validity. Content validity is created by ensuring consistency between metrics and existing literature. This validity was obtained by a survey of professors. Convergent validity refers to the principle that the indices of each

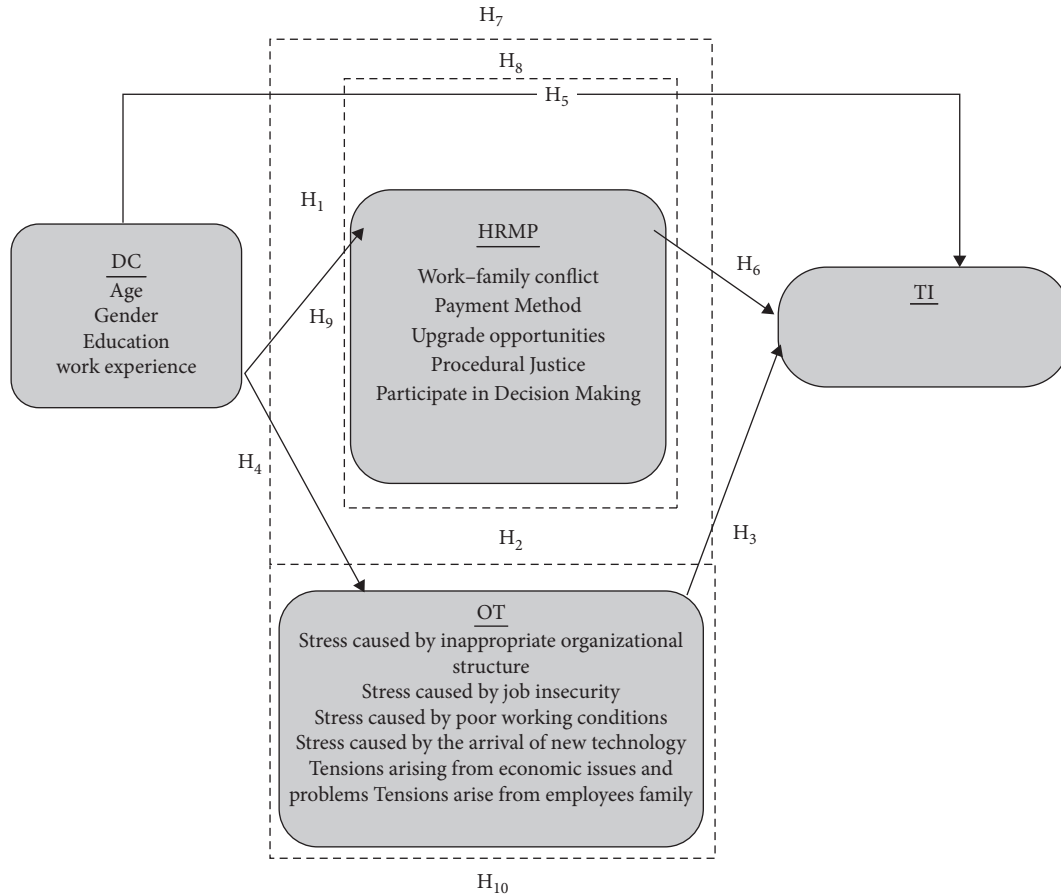

FIGURE 1: Conceptual model of research.

structure have an intermediate correlation with each other. According to Fornell and Larcker [18], the criterion of convergence validity is that the mean output variance (AVE) is greater than 0.05. Divergent validity was also measured by comparing the AVE root with the correlation between latent variables (Table 1), and for each of the reflective structures, the AVE root should be greater than the correlation of that structure with other structures in the model of Choua and Chen [19]. Also, in this study, three criteria (Cronbach's alpha coefficient, composite reliability coefficient, and Rho coefficient) were used to determine the reliability of the questionnaire according to Fornell and Larcker [18]. Cronbach's alpha coefficients of all variables in this study are greater than the minimum value (70.0). Composite reliability, like Cronbach's alpha, which implicitly assumes that each index has the same weight, relies on the actual factor loads of each structure and therefore provides a better measure of reliability. The reliability of the compound should be a value greater than 0.70 to indicate the internal stability of the structure. Tables 2 and 3 give the results of reliability and validity of the measurement tool in full.

3.1. Research Findings. In this research, the partial least-squares method has been used, which is a method for structural equation modeling. Structural equation modeling is the only tool for analyzing path or causal models. The path

TABLE 1: Separation of total, direct, and indirect effects.

Relationships	Direct effects	Indirect effects	Total effects
DC→HRMP	0.927	—	0.927
HRMP→OT	0.261	—	0.261
OT→TI	0.104	—	0.104
DC→OT	0.258	0.30	0.558
DC→TI	0.169	0.186	0.355
HRMP→TI	0.014	0.166	0.18

model of this research has at least three dependent variables, of which two dependent variables play the role of independent variables for the third dependent variable. In this study, the variable of turnover intention is a variable dependent on the demographic characteristics of employees and the choice of human resource management methods on organizational tensions, and organizational tensions is a variable dependent on the demographic characteristics of employees and the choice of human resource management methods. Also, the choice of human resource management methods is a variable dependent on the demographic characteristics of employees. In fact, this method is a combination of principal component analysis (which links indicators to latent variables) and path analysis (which allows a system of latent variables to be created). Estimation of parameters representing indices and path relationships is done using conventional least-squares techniques. In this

TABLE 2: Convergent validity and reliability of measurement tools.

Research variables	AVE	Factor loads		Rho	CCR	Cronbach's alpha
		β	t			
<i>Demographic characteristics (DC)</i>	0.65	—	—	0.830	0.88	0.820
Age	—	0.87	22.24	—	—	—
Gender	—	0.86	16.32	—	—	—
Education	—	0.85	12.85	—	—	—
work experience	—	0.84	10.37	—	—	—
<i>Selection of human resource management methods (HRMP)</i>	0.63	—	—	0.85	0.89	0.850
Work-family conflict	—	0.87	28.51	—	—	—
Payment method	—	0.83	19.91	—	—	—
Upgrade opportunities	—	0.77	12.17	—	—	—
Procedural justice	—	0.75	14.32	—	—	—
Participate in decision-making	—	0.71	8.47	—	—	—
<i>Organizational tensions (OT)</i>	0.61	—	—	0.87	0.90	0.870
Stress caused by inappropriate organizational structure	—	0.90	44.63	—	—	—
Stress caused by job insecurity	—	0.82	15.855	—	—	—
Stress caused by poor working conditions	—	0.81	12.973	—	—	—
Stress caused by the arrival of new technology	—	0.78	10.21	—	—	—
Tensions arising from economic issues and problems tensions arising from employees' family problems	—	0.75	4.103	—	—	—
<i>Turnover intention (TI)</i>	0.100	—	—	0.100	0.100	0.100

TABLE 3: Correlation matrix and divergent validity study.

	DC	HRMP	OS	TI	AVE
Demographic characteristics (DC)	1				0.81
Selection of human resource management methods (HRMP)	0.927	1			0.79
Organizational tensions (OT)	0.273	0.239	1		0.78
Turnover intention (TI)	0.168	0.014	0.103	1	0.100

method, the researcher must first determine the structure of the model and the relationships of the indicators. The software used in this research is SMARTPLS. This software uses the partial least-squares method to present structural equation models. This software is suitable for testing the moderating effect of software (Fornell and Larcker) [18]. Esposito Vinzi et al. [20] stated that PLS path models are estimated in two stages. In the first stage, the score of hidden variables is estimated for each hidden variable, and in the second stage, the moderating role of hidden variables is estimated, depending on their status in the route model. Due to the nature of the second step, many of the recommendations are to test the moderation effect of multiple regression through SMARTPLS software. In the following, the outputs of the software and their analysis are given.

3.1.1. Measurement Model. The contents and the results obtained from the outputs of SMARTPLS software in the above tables show that the measuring instrument has appropriate validity (content, convergent, divergent) and reliability (factor load, composite reliability coefficient, alpha Cronbach's coefficient).

3.1.2. Structural Model. Structural equation modeling has been a common research tool in management, medicine, and the social sciences for the last two or three decades. According to the issues raised in this section, using

SMARTPLS, the effectiveness or ineffectiveness of the mentioned factors is investigated as follows.

1) Significant numbers z (T -values) and path coefficients β are a criterion for measuring the relationship between structures in the model (structural part). It is noteworthy that T -value shows the significance of the effect of variables. If the value of T is greater than 1.96, then there is a positive effect and it is significant. If this value is between $+1.96$ and -1.96 , then there is no significant effect, and if this value is less than -1.96 , then it has a negative effect but it is significant. Also, path coefficients, if they are above 0.6, mean that there is a strong correlation between the two variables. If it is between 0.3 and 0.6, then there is a moderate correlation, and if it is below 0.3, then there is a weak correlation. The data obtained from the field research were performed in SMARTPLS software, and the above results were obtained according to Figures 2 and 3. The analysis of each relationship, which in fact reflects the research hypotheses, is shown in a useful and brief way in Tables 1 and 4.

According to Table 4, which is based on the results of testing the research hypotheses, it can be said that the result of testing the first hypothesis, with respect to the path coefficient of 0.927 and the value of $T=10.425$, shows that the demographic characteristics of employees have a significant and strong effect on the choice of human resource management methods. In testing the second hypothesis with a path coefficient of 0.261 and a value of $T=4.921$, it was concluded that the choice of human resource management

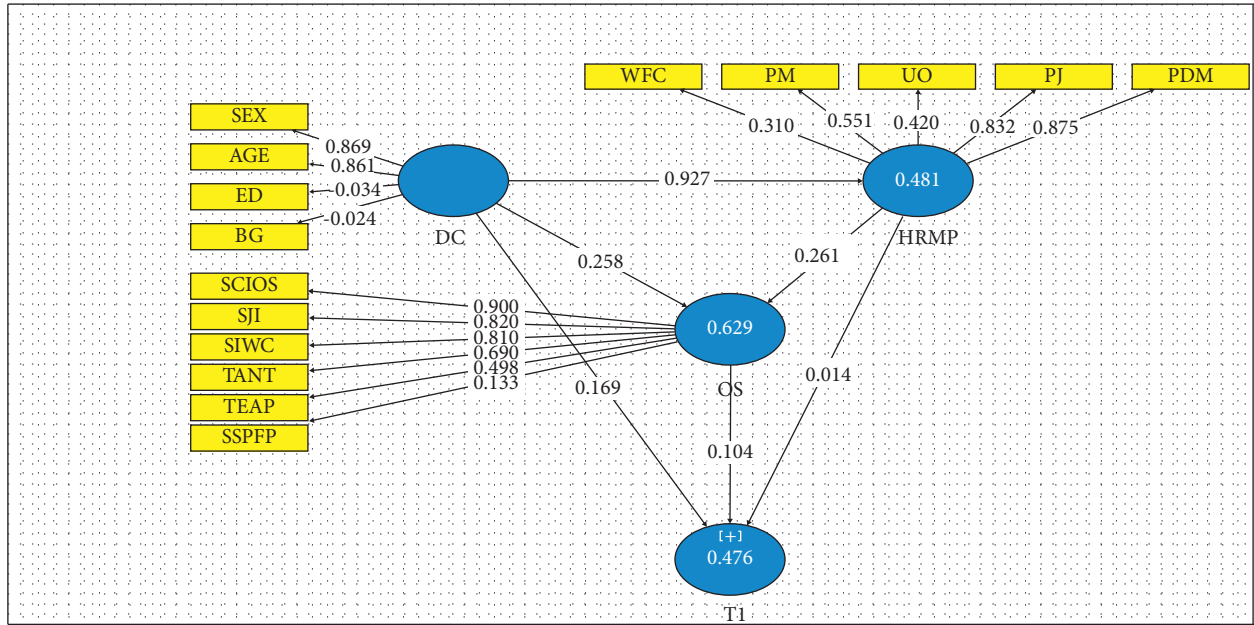

FIGURE 2: Model path coefficients.

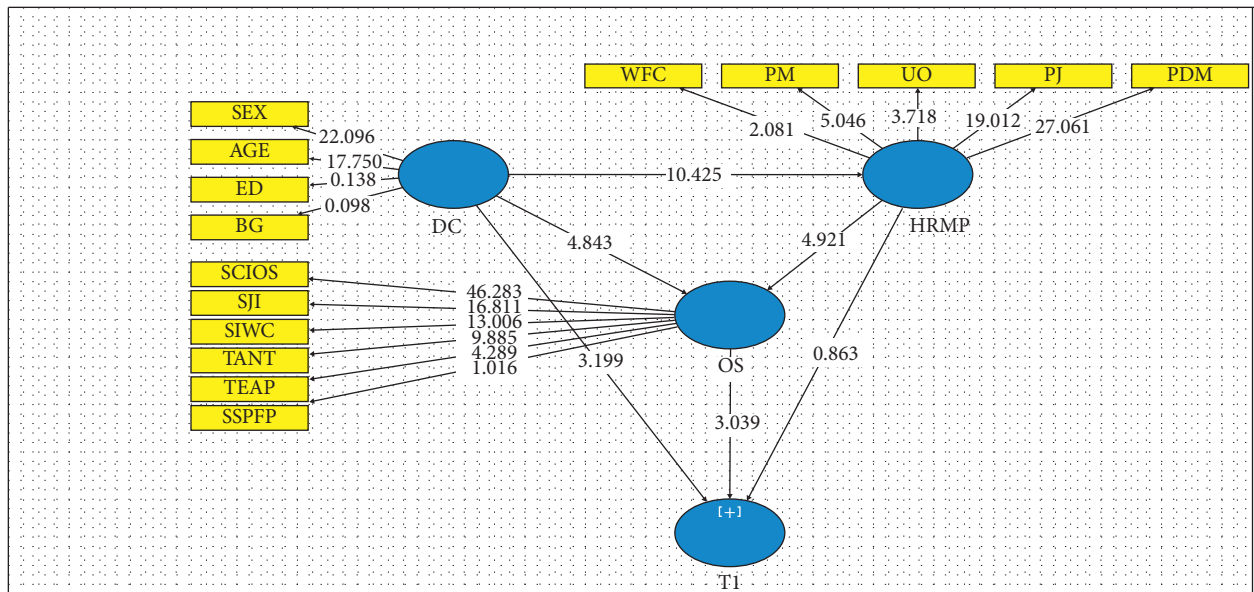

FIGURE 3: t-Test results.

TABLE 4: Summary of the results of the hypothesis test.

Variables	Path coefficient	T	Significance level	Impact rate
DC→HRMP	0.927	10.425	Significant	Strong
HRMP→OT	0.261	4.921	Significant	Medium
OT→TI	0.104	3.039	Significant	Medium
DC→OT	0.258	4.843	Significant	Medium
DC→TI	0.169	3.199	Significant	Medium
HRMP→TI	0.014	0.863	Significant	Weak

methods has a significant and moderate effect on organizational stress. The results of testing the third hypothesis with a path coefficient of 0.104 and a value of $T=3.039$ indicate that organizational stress has a significant and

moderate effect on retirement goals. The results of the fourth hypothesis test, with a path coefficient of 0.258 and a value of $T=843/4$, indicate that the demographic characteristics of employees have a significant and moderate effect on

organizational stress. The results of testing the fifth hypothesis with a path coefficient of 0.169 and a value of $T=3.199$ indicate that the demographic characteristics of employees have a significant and moderate effect on retirement purposes. The results of testing the sixth hypothesis with a path coefficient of 0.014 and a value of $T=0.863$ indicate that the choice of human resource management methods has a significant and weak effect on retirement purposes. To examine the extent of direct and indirect effects of independent variables on dependents, it is necessary to provide total, direct, and indirect effects for the endogenous variables of the model (Table 1).

As Table 1 shows, demographic characteristics of employees have a direct and significant effect on the choice of human resource management methods, but also have a direct, indirect, and significant effect on organizational tensions and turnover intention. Human resource management has a direct and significant effect on organizational tensions, but has both direct and indirect effects on turnover intention. Finally, organizational tensions have a direct and significant effect on turnover intention. Finally, it can be said that the mediating role of the selection of human resource management methods and organizational tensions on the demographic characteristics of employees and turnover intention were supported. In other words, the indirect effect of demographic characteristics of employees on the purposes of turnover intention with the presence of the role of selecting human resource management methods and organizational tensions (indirect effect = 0.186) is greater than the direct effect of demographic characteristics of employees on turnover intention (direct effect = 0.169). In other words, considering the total effect (0.355) of demographic characteristics of employees on dismissal purposes, it can be concluded that the demographic characteristics of employees with the help of mediating variables (selection of human resource management methods and organizational tensions) have a better effect on turnover intention. Therefore, the seventh to tenth hypotheses of this study were also confirmed. However, it is important that if the mediator role wants to show its effect better, it should be possible to examine their significant effects (t -test) with the Sobel test and confirm the significant conditions mentioned above. Here, for the seventh to tenth hypotheses, the significant effects are 2.63, 2.67, 4.58, and 2.99, respectively. According to the t -test, the effects of the independent variable on the mediating variable and the effect of the mediating variable on the dependent variable are obtained.

3.2. Model Fit. In PLS models, two models are tested, the outer model that is equivalent to the measurement model and the inner model that is similar to the structural model in other software packages such as LISREL, EQS, and AMOS. The outer model (measurement) is a model that determines the relationship between latent variables and explicit and observed variables. To fit this model, the cross-validated communality index (an index used to check the fit of a measurement model of a block of "latent variable") is used. Also, the inner (structural) model is a model that determines

the relationship between latent variables, and the index of cross-validated redundancy (Edgar and Geare coefficient Q^2) has been used to fit the structural model, which predicts the indicators of endogenous latent variables (R^2). If these two indicators (cross-validated communality index and cross-validated redundancy index) are positive, it indicates the appropriate quality of the structural model. However, as can be seen in Table 5, the two abovementioned turnover intention indices are positive, which indicates the appropriate quality of the model. The value of R^2 , which indicates the ability of the model to describe the structure, is 0.48 and 0.63 for human resource management methods and organizational tensions, respectively. Also, the value of R^2 for turnover intention purposes is equal to 0.48 when the mediating role of human resource management methods and organizational tensions is examined. The following results show that the proposed model has a good fit.

4. Discussion

As mentioned, the purpose of this study was to investigate the effect of demographic characteristics of employees and the selection of human resource management methods on organizational tensions and turnover intention at Payame Noor University in Kermanshah Province. The results of the first hypothesis showed that the demographic characteristics of employees affect the choice of human resource management methods. This result is in line with the results obtained in the research of Akbari and Ali Akbari [8]; Edgar and Geare [9]; and Demir and Uyargil [14]. Demographic characteristics of employees can be a way to better categorize employees in organizational positions. Therefore, due to the importance of choosing human resource management methods, the demographic characteristics of employees can provide the necessary tools for better selection of management methods and selection of employees. Therefore, Payame Noor University should pay enough attention to the role of "demographic characteristics" in order to be able to influence the choice of human resource management methods and to be able to better control the organization.

Furthermore, the results obtained in the second hypothesis indicate that the choice of human resource management methods has an effect on organizational tensions. Confirming this hypothesis, we can say that today the world is called the world of organizations and their trustees are considered human beings, because human resources are the most valuable resource for organizations. Therefore, paying attention to this resource should be very important, as every employee in the organization to achieve organizational goals must be properly motivated because this factor is effective in reducing organizational tensions. These statements prove that the choice of human resource management methods can reduce organizational tensions. Therefore, the relevant university should be able to pay enough attention to this issue in order to reduce organizational tensions and increase the productivity of its human resources.

The results of the third hypothesis also indicate the fact that organizational tensions affect the turnover intention. This result is similar to the results obtained in research

TABLE 5: Model fit.

Variable	Measurement model	Structural model	R^2
	Cross-validated communality	Cross-validated redundancy	
Demographic characteristics (DC)	—	0.109	—
Selection of human resource management methods (HRMP)	0.175	0.177	0.48
Organizational tensions (OT)	0.269	0.309	0.63
Turnover intention (TI)	0.353	0.1000	0.48

conducted by Ebrahimi Nejad et al. [5]. Therefore, in confirming this hypothesis, it can be said that in today's organizations, reducing organizational turnover intention tensions can be a source of human resource development in the organization, because, sometimes, this factor will be able to reduce the turnover intention. Since human beings are the focus of productivity, it is important for managers of today's organizations to reduce their turnover intention goals. Good human resources are able to increase the competitive advantage of the organization in which they work. In this way, reducing organizational tensions can help human resources, so that employees learn how to influence the reduction in turnover intention goals, such that they can also achieve a "competitive advantage" and increase the productivity of the system. Therefore, the relevant university should pay attention to the importance of the role of factors in reducing organizational tensions in this field, in order to achieve a competitive advantage.

The results of the fourth hypothesis also indicate the fact that the demographic characteristics of employees affect organizational tensions. This result is similar to the results of research conducted by Dartey-Baah [21] and Hassani et al. [16]. Therefore, to confirm this hypothesis, it should be said that in today's organizations, the demographic characteristics of employees can be a way to better categorize employees in organizational positions. Therefore, in this way, organizational tensions can be reduced. Hence, the relevant university should use the role that the demographic characteristics of employees play in this field to reduce organizational tensions.

The results of the fifth hypothesis also indicate the fact that the demographic characteristics of employees affect the turnover intention. This result is in line with the results obtained in research conducted by Akbari and Ali Akbari [8]; Agyeman and Ponniah [13]; and Likoko [14]. Therefore, in confirmation of this hypothesis, it should be said that in today's organizations, demographic characteristics of employees can be a way to better categorize employees in organizational positions. Therefore, in this way, the intentions of turnover intention can be reduced. Therefore, the relevant university should pay attention to the importance of the role played by the demographic characteristics of the staff in this regard, in order to reduce the intentions of turnover intention.

The results of the sixth hypothesis also indicate the fact that the choice of human resource management methods affects the intentions of turnover intention. This result is in line with the results obtained in research conducted by Akbari and Ali Akbari [9]; Kanaani Rangriz and Mahzabi [8]; Kanaani [6]; Ikhlās and Al-Kilani [11]; and Gadi and Kee

[12]. Therefore, in confirmation of this hypothesis, we can say that in today's organizations, as mentioned, their trustees are human beings. Therefore, human resources are the most valuable resource for organizations. Therefore, attention to this resource should be increased, because this factor is an effective factor in reducing the turnover intention. These statements prove that the choice of human resource management methods can reduce the intentions of turnover intention. Therefore, the relevant university should be able to pay enough attention to this issue in order to reduce the intentions of turnover intention and increase the productivity of its human resources.

The results of the seventh hypothesis also stated that organizational tensions play a mediating role in influencing the demographic characteristics of employees on turnover intention. By confirming the fifth hypothesis, it is concluded that through demographic characteristics such as age, the tendency of employees to leave their jobs can be reduced. Also, considering the confirmation of the third hypothesis of the research, namely, "the effect of organizational tensions on the purposes of turnover intention," it can be hoped that by reducing organizational tensions, employees can be encouraged not to turnover intention in the organization. Therefore, the relevant university should pay enough attention to the importance of reducing the effects of organizational tensions in order to increase the effects that the demographic characteristics of employees have on the purposes of turnover intention.

The results of the eighth hypothesis also state that organizational tensions play a mediating role in influencing the choice of human resource management methods on turnover intention. By confirming the sixth hypothesis, it can be said that the choice of human resource management methods to better manage employees by the management of the organization has been in the realm of organizational behavior for many years. Since human resources are the main and irreplaceable assets of the organization, so that the success and survival of the organization depend on them, therefore, the employees of the organization should be wary of turnover intention, to reduce the tendency to leave their jobs. Also, considering the confirmation of the third hypothesis of the research, namely, "the effect of organizational tensions on the intentions of turnover intention," it can be hoped that by reducing organizational tensions, employees can be encouraged not to turnover intention in the organization. Therefore, the relevant university should pay enough attention to the importance of reducing the negative effects of organizational tensions in order to increase the effects that the choice of human resource management methods can have on the intentions of turnover intention.

The results of the ninth hypothesis also indicate that the choice of human resource management methods has a mediating role in influencing the demographic characteristics of employees on organizational tensions. By confirming the fourth hypothesis, organizational tensions, which are created due to the role of employees in the organization, can be reduced through demographic characteristics such as age. Since human resources are the main and irreplaceable assets of the organization, the success and survival of the organization depend on them. Therefore, the employees of the organization should avoid organizational tensions. Also, considering the confirmation of the third hypothesis of the research, namely, "the effect of choosing human resource management methods on organizational tensions," it can be hoped that, given the positive effects that human resource management methods have on organizational tensions, the effects of demographic characteristics of employees on organizational tensions will be doubled. Therefore, the relevant university should pay enough attention to the importance of the role of human resource management methods in order to be able to show the positive effects that the demographic characteristics of employees can have on their organizational tensions.

The results of the tenth hypothesis also state that the choice of human resource management methods has a mediating role in influencing the demographic characteristics of employees for the purposes of turnover intention. By confirming the fifth hypothesis, it is concluded that through demographic characteristics, such as age, the tendency of employees to leave their jobs can be reduced. Also, given the confirmation of the research's sixth hypothesis, "the effect of choosing human resource management methods on turnover intention goals," we can hope that the positive effects of human resource management methods on turnover intention goals in the organization will be doubled the effects of demographic characteristics on turnover intention. Therefore, the relevant university should pay enough attention to the importance of the role of human resource management methods in order to show the positive effects that the demographic characteristics have on the intentions of turnover intention.

Finally, considering the results of the structural equation model, it is concluded that this conceptual model of research can be used as an experimental model, which can be a guide and basis for future scientific and practical research.

5. Conclusion

According to the research findings, it should be said that the relevant university must resort to appropriate methods of human resource management in order to reduce organizational stress and leave intentions. Of course, in this way, university administrators can use the demographic characteristics of employees to help them choose the best management method. Finally, considering the results of the structural equation model, it can be said that this conceptual model of research can be considered as an experimental model that can be a guide and basis for future scientific and practical research.

5.1. Research Limitations. The fewer limiting factors in a study, the more controllable the research variables will be, and examining the relationship between these variables will provide more accurate and scientific results. Therefore, it is necessary that these restrictions are communicated to future researchers in order to consider the negative impact of these restrictions on their research. Researchers face two types of constraints before and during any research, which are constraints that researchers have had and controllable and constraints that are beyond their control. This research also faces a number of limitations of both types, which are as follows.

5.1.1. Limitations Available to Researchers

- (1) Only the university centers of Payame Noor University in Kermanshah Province have been studied in this research, and in terms of research objectives and time constraints, other university centers of this university in other provinces have not been included. It should be noted that Payame Noor University has branches in all cities in Iran.
- (2) In this study, the staff is only administrative, and faculty members and students are not part of the study population.

5.1.2. Restrictions beyond the Authority of Researchers. (1)

The basic and unavoidable limitation of this research is the use of a questionnaire to measure the number of variables. The results obtained depend to a large extent on the perception, interpretation, and analysis of the researcher and the respondents to the subject, and it is not possible to determine their accuracy.

- (2) Inadequate access to theses and related articles on specialized websites, as well as a lack of resources and books on applicable research and models.
- (3) Concern among relevant university staff that their responses and research findings will have a negative impact on their service status, salaries and benefits, and future careers. As a result, some university staff have responded conservatively to a number of questions or even delivered some unanswered questions.

5.2. Suggestions for Future Research

- (1) It is recommended that researchers, using the variables of this research, conduct this research as a provincial comparison between the executive organs of the country and compare the obtained results with the results of this research.
- (2) It is recommended that researchers conduct this research in noneducational organizations, with the same variables as a relationship or comparison between national organizations, and compare the obtained results with the results of this research.

- (3) It is recommended that researchers use the variables of this research to conduct this research in the future with more organizations and with more courses using the methodology of this research in order to increase the validity and reliability of the model estimated in this study.

Data Availability

Data can be obtained from the corresponding author on request.

Conflicts of Interest

The authors declare that there are no conflicts of interest regarding the publication of this manuscript.

Authors' Contributions

All authors contributed equally to the writing of this study. All authors read and approved the final manuscript.

Acknowledgments

This article is derived from a grant project sponsored by Payam Noor University

References

- [1] S. Khilji and X. Wang, "New evidence in an old debate: investigating the relationship between HR satisfaction and turnover," *International Business Review*, vol. 16, no. 3, pp. 377–395, 2007.
- [2] Z. Michel, N. S. Nabeel, and A. ElSharif, "The impact of human resource management methods on organizational commitment in the banking sector in Kuwait," *International Journal of Business and Management*, vol. 6, 2011.
- [3] K. B. Komal and N. Samina, "Determinants of organizational commitment in banking sector," *International Journal of Academic Research*, vol. 3, no. 4, pp. 468–474, 2011.
- [4] B. Saeidipour and P. Akbari, *The Role of Employee Demographic Characteristics and Selection of Human Resource Management Methods on Organizational Tensions and Turnover Intention*, Payame Noor University, Tehran, Iran, 2020.
- [5] M. Ebrahimi Nejad, G. Ebrahiminejad, and M. Yari Nasirieh, "Investigating the relationship between organizational tensions and employees' willingness to leave the service in government organizations," *Daneshwar Speed*, vol. 16, no. 38, pp. 35–44, 2018.
- [6] A. Kanaani, *The Impact of Human Resource Management Measures on the Turnover Intention in Small and Medium Businesses*, *Scientific Conference on Management, Applied Economics and Trade*, Shiraz, Kharazmi Higher Institute of Science and Technology, Tehran, Iran, 2018.
- [7] M. H. Zahedi, A. A. Rezaei, V. M. Darini, and E. N. Joyimi, "Designing a model for selecting and implementing organizational resource planning systems in government and government subordinate organizations," *Journal of Management of Government Organizations*, vol. 6, no. 3, pp. 131–144, 2019.
- [8] H. Rangriz and M. Mohzzabi, "Human resource management measures and the tendency to leave the organization: investigating the mediating role of psychological contract violation," *Human resource management in the oil industry*, vol. 10, no. 40, pp. 97–120, 2019.
- [9] P. Akbari and M. A. Akbari, *The Effect of Demographic Characteristics of Employees and Selection of Human Resource Management Methods on Leaving the Service, the First National Conference on Management and Economics with the Approach of Resistance Economy*, Payame Noor University of Khorasan Razavi, Mashhad, Iran, 2019.
- [10] F. Edgar and A. Geare, "Employee demographics in human resource management research," *Research and Method in Human Resource Management*, vol. 12, pp. 61–91, 2004.
- [11] A. Ikhlas and M. H. Al-Kilani, "Human resource management and turnover intentions in the Jordanian hotel sector," *Research and Method in Human Resource Management*, vol. 18, pp. 46–59, 2010.
- [12] P. Gadi and D. Kee, "Human resource management methods and turnover intention: the mediating role of perceived organizational support in tertiary institutions in Nigeria," *International Journal of Engineering & Technology*, vol. 7, 2018.
- [13] C. M. Agyeman and V. M. Ponniah, "Employee demographic characteristics and their effects on turnover and retention in MSMEs," *International Journal of Recent Advances in Organizational Behaviour and Decision Sciences (IJRAOB)*, vol. 1, 2014.
- [14] S. Likoko, J. Ndiku, and S. Mutsotso, "Influence of demographic characteristics on turnover intentions among the academic staff in public diploma teacher training colleges in Kenya," *International Journal of Science and Research (IJSR)*, vol. 7, no. 8, pp. 781–785, 2018.
- [15] R. Demir and C. Uyargil, "A study on the relation between the demographics of human resource managers in Turkey and characteristics of their companies," *International Journal of Human Resource Studies*, vol. 7, pp. 212–230, 2017.
- [16] K. Hasani, S. Sadeghi Boroujerdi, S. Sheikhesmaeili, and T. Aeini, "Identity of organizational conflict framework: evaluating model factors based on demographic characteristics in Iran," *Journal of Industrial Engineering and Management JIEM*, vol. 7, 2018.
- [17] K. Dartey-Baah, "Work-family Conflict, Demographic Characteristics and Job Satisfaction among Ghanaian Corporate Leaders," *International Journal of Business*, vol. 20, no. 4, pp. 291–307, 2015.
- [18] C. Fornell and D. Larcker, "Evaluating structural equation models with unobservable variables and measurement error," *Journal of Marketing Research*, vol. 18, no. 1, 1981.
- [19] C. Shih-Wei and C. Pi-Yu, "The influence of individual differences on continuance intentions of enterprise resource planning (ERP)," *International Journal of Human-Computer Studies*, vol. 67, no. 6, pp. 484–496, 2009.
- [20] V. Esposito Vinzi, W. Chin, J. Henseler, and H. Wang, *Handbook of Partial Least Squares: Concepts, Methods and Applications Computational Statistics Handbook Series*, Springer, Berlin, Germany, 2010.
- [21] K. Dartey-Baah, "Work-family conflict, demographic characteristics and job satisfaction among Ghanaian corporate leaders," *International Journal of Business*, vol. 20, pp. 291–307, 2015.