

## Research Article

# Cocompetitive Characteristics and Quantitative Design of Engineering Parameters for Coal Gas Pre-drainage Boreholes

Tong-qiang Xia <sup>1,2</sup>, Jiao-fei He <sup>1</sup>, Zi-long Li,<sup>1</sup> Xiao-yan Sun,<sup>3</sup> Dun-shuai Sun,<sup>1</sup> Jian-hang Lu,<sup>1</sup> and Hao-jie Cui<sup>1</sup>

<sup>1</sup>School of Low Carbon Energy and Power Engineering, China University of Mining and Technology, Xuzhou, Jiangsu 221116, China

<sup>2</sup>State Key Laboratory of Oil and Gas Reservoir Geology and Exploitation, Chengdu University of Technology, Chengdu 610059, China

<sup>3</sup>Hancheng Zaozhuang Industrial Co., Ltd., Yellow River Mining Group, Hancheng Shaanxi 715400, China

Correspondence should be addressed to Tong-qiang Xia; [xtq09cumt@163.com](mailto:xtq09cumt@163.com)

Received 23 February 2022; Accepted 2 June 2022; Published 28 June 2022

Academic Editor: Zhenlong Song

Copyright © 2022 Tong-qiang Xia et al. This is an open access article distributed under the Creative Commons Attribution License, which permits unrestricted use, distribution, and reproduction in any medium, provided the original work is properly cited.

Quantitative design of the optimal gas extraction engineering parameters has always been a key scientific problem to meet the pre-drainage target of the coal seam, which is paid great attention to and urgently expected to solve for the gas extraction engineering of coal mine. In this paper, the governing equation of the evolution of coal seam gas content is established under the interference and cooperation of gas extraction by boreholes, and the calculation formula of gas cooperative efficiency is defined. Based on gas-air mixed flow, a multifield coupling 3d model of coal gas extraction using boreholes was developed. The content, method, and principle of optimal spacing parameter design of extraction borehole were proposed, and the constraint conditions and objective function of optimal design were constructed. The flow characteristics of gas extraction using boreholes in the coal seam area and the influence of different parameters on gas extraction effect are studied. The cooperative and competitive behaviors of gas extraction by boreholes in coal seam are revealed. The results show that borehole spacing, seam fracture permeability, and gas adsorption constant have significant effects on the synergistic and competitive effects of gas extraction, while the negative pressure of gas extraction and coal matrix permeability have little effects, but the negative pressure of gas extraction has great effects on gas extraction concentration. Finally, Comsol With Matlab is used to solve the multiconstraint nonlinear optimization problem of gas drainage engineering parameters along coal seam in 18401 working face of Tunlan Coal Mine. The effect of actual gas extraction investigation is very remarkable, which provides a quantitative calculation basis for scientific gas extraction in coal mine.

## 1. Introduction

Coal is still one of the most important energy sources in the world for a long time, and safety and efficiency in coal mining are particularly important [1, 2]. Gas accident is the “first killer” threatening the safety production and the biggest hidden danger of coal mine to achieve the goal of “zero gas overrun, zero coal seam outburst, and zero enterprise death” [3, 4]. Order [2015] No. 82 of the State Administration of Work Safety issued 10 regulations on strengthening coal mine gas control, such as “pumping before excavation, pumping before mining, and pumping up to standard.” At present, in the technology of gas

accident prevention and gas control, in addition to ensuring good ventilation network and environment, gas drainage using coal seam borehole is one of the most commonly used and effective methods [5, 6]. A coal seam borehole is an artificial channel established between coal seam gas and drainage pipeline system. The scientificity and rationality of borehole design directly affect the difficulty and quantity of drilling construction, as well as the exertion of later drainage efficiency [7]. However, the design of coal seam gas drainage mainly depends on experience, resulting in a tight gas pre-drainage period and conflict with mining operation, so that the unsafe mining phenomenon generally exists when the drainage effect is not up to

standard [8]. How to scientifically predict the effect under different engineering design parameters of gas drainage (such as borehole spacing, diameter, and negative pressure) and then quantitatively design the best engineering parameters to meet the predrainage target of coal gas is a key scientific problem of gas drainage engineering. Domestic and foreign scholars have paid great attention to and urgently expect to solve it in recent years.

Numerous studies have shown that gas extraction is a complex multifield coupled process, which involves gas transport and solid deformation of the coal body, with the various processes interlocking and influencing each other [9–13]. In the experimental and theoretical studies on the multifield coupled flow of coal gas, Yang et al. introduced the coupled equations of the evolution of stress, damage, and permeability coefficients induced by the mining disturbance influence; then, a model for the coupled solid-gas action of the coal rock fracture process was established [14]. Lu et al. studied the effective radius of borehole gas drainage by the numerical simulation method [15]. Li et al. proposed to determine the relationship between the borehole spacing and the effective extraction radius by using the method of gas content in the coal body around boreholes at a specific moment [16]. Guo et al. established a gas-solid coupling model based on the characteristics of double porosity medium structure by considering the influence of double porosity medium and gas slippage effect of coal body, carried out numerical calculation and analysis by the finite element method, and gave the reasonable extraction spacing of boreholes [17]. Hu et al. considered the Klinkenberg effect of gas flow in low-permeability coal medium and the dynamic change of the coal pore structure with mining stress and gas pressure, respectively, obtained the dynamic evolution model of coal permeability and porosity, and deduced the solid-gas coupling model of low-permeability coal seam [18]. Aiming at the reasonable layout of gas drainage boreholes in coal seam, Wang et al. analyzed the influence radius of single-borehole gas drainage by establishing the seepage field control equation and coal seam deformation field control equation of borehole gas drainage [19]. Hao et al. established a seepage-stress coupling model considering the rheological characteristics, dynamic changes of permeability, and adsorption characteristics of coal and determined the reasonable drainage radius of coal seam [20]. Liang et al. established a solid-gas coupling model to simulate the effective drainage radius of No. 4 coal seam in Shaqu mine, based on the processes of fracture gas seepage, micropore adsorption, desorption and diffusion, and coal-rock mass deformation [21]. We firstly consider the objective gas leakage characteristics during the gas extraction process and coupled the multiphysical processes under the action of gas drainage such as coal deformation, matrix gas seepage, and fracture air-gas mixed flow, and the 2d simulation of gas drainage was carried out by using a single borehole [22].

To sum up, the research of domestic and foreign scholars on the gas drainage fluid structure coupling model enriches the gas multiphysical coupling theory but rarely considers the engineering practical problem of drainage concentration attenuation caused by fracture leakage around the borehole.

At the same time, the simulation of the gas drainage effect of 3d boreholes is rarely considered, while the gas drainage effect of single borehole simulation has a great deviation from the engineering practice. In order to solve the above problems, based on the multiphysical coupling model of gas drainage developed in the early stage [22], this paper puts forward the content, principle, and method of parameter design of gas drainage engineering and focuses on the characteristics of gas flow in coal seam area and the influence of different gas storage characteristics and drainage parameters on gas drainage effect. On this basis, the 18401 working face of Tunlan Coal Mine, which belongs to Xishan Coal Electricity, is quantitatively designed, which provides theoretical and technical support for the parameter design of gas drainage engineering.

## 2. The Extraction Characteristics and Quantitative Design Model of the Boreholes

*2.1. Analysis on Interference Characteristics of Borehole Extraction.* Coal seams are a typical pore-fracture system, and gas exists mainly in adsorbed and free states in the pore fracture of the coal body, of which about 90% of the gas is adsorbed in the micropores of the coal matrix and its surface and less than 10% of the gas is free in the fracture and macropores [23, 24]. In the process of gas extraction, free gas from the coal matrix and fracture system as well as outside air from the wall of the roadway seeps into the coal seam borehole due to the drainage effect of negative extraction pressure. At the same time, the gas desorption-diffusion in the matrix causes the coal deformation and then affects the permeability of the coal matrix and fracture system [25]. The distribution of residual gas content around single and double boreholes is shown in Figure 1 [25]. In the figure,  $r_0$  indicates the radius of the borehole,  $L$  is the effective extraction length of the predrainage borehole,  $W_0$  is the original gas content of the coal seam, and  $W_c$  is the gas content at the boundary of the coal seam borehole.  $W$  is the gas content at distance  $r$  from the center of extraction borehole;  $r_{e1}$  and  $r_{e2}$  are the radius of influence of single-hole extraction of  $Z_1$  and  $Z_2$ , respectively;  $L_z$  is the spacing between  $Z_1$  and  $Z_2$  boreholes;  $W_1$  and  $W_2$  are the residual gas content in the area around the borehole after single-hole extraction of  $Z_1$  and  $Z_2$ , respectively;  $\Delta W_1$  is the gas extraction capacity per ton of coal at radial distance  $r$  from single-hole  $Z_1$ ; and  $\Delta W_2$  is the gas extraction capacity per ton of coal at radial distance  $L_z - r$  from single-hole  $Z_2$ .

The relationship between total extraction volume  $Q$  and radial gas content at a specific point in the borehole extraction can be expressed as [26]

$$Q = \int_{r_0}^{r_e} (W_0 - W_r) \rho L 2\pi r dr, \quad (1)$$

where  $Q$  is the gas extraction volume of the borehole ( $\text{m}^3$ ) and  $\rho$  is the apparent density of coal ( $\text{m}^3/\text{t}$ ).

In the process of gas extraction of the boreholes, if the sum of the influence radius of adjacent holes is greater than

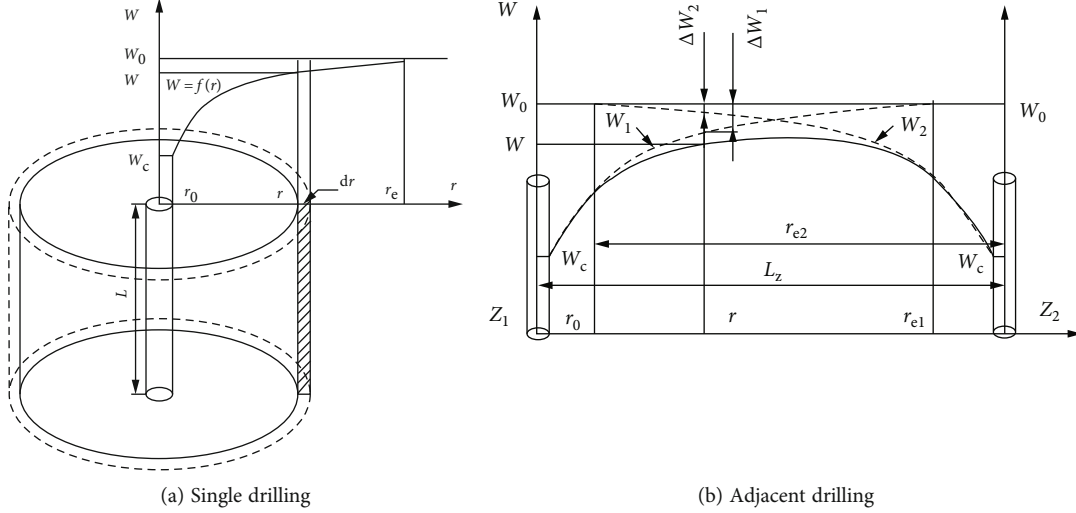

FIGURE 1: Evolution diagram of residual gas content around single and double boreholes [25].

the distance between holes, the gas extraction effect of the boreholes will be affected by the superposition effect of adjacent holes, and the pressure and content of coal seam gas extraction will decay faster. At the same time, because the pressure and content decay faster, there is a certain interference in gas extraction between boreholes. Then, the gas content at  $r$  is

$$W_r = W_0 - (\Delta W_1 + \Delta W_2) + \Delta W', \quad L_z \leq r_{e1} + r_{e2}, \quad (2)$$

where  $\Delta W_1$  is the gas extraction capacity per ton of coal at radial distance  $r$  of the single-borehole  $Z_1$ ,  $\Delta W_2$  is the gas extraction capacity per ton of coal at radial distance  $L_z - r$  of the single borehole  $Z_2$ , and  $\Delta W'$  is the relative attenuation of gas extraction capacity per ton of coal at radial distance  $r$  of the borehole  $Z_1$ , which is caused by borehole interference.

$\Delta W_1$  and  $\Delta W_2$  in the above equation can be expressed as

$$\begin{cases} \Delta W_1 = W_0 - W_1, \\ \Delta W_2 = W_0 - W_2. \end{cases} \quad (3)$$

If the sum of the radius of influence of adjacent boreholes is less than the spacing of boreholes, it means that there is no superposition effect of extraction effect between extraction boreholes, and the actual effect of gas extraction is the same as that of single-borehole extraction. That is,

$$W_r = W_1, \quad L_z > r_{e1} + r_{e2}. \quad (4)$$

Substituting equation (3) into equation (2) yields the relative gas extraction capacity attenuation per ton of coal due to borehole disturbance:

$$\Delta W' = W_r + W_0 - W_1 - W_2, \quad L_z \leq r_{e1} + r_{e2}. \quad (5)$$

To quantitatively analyze the cooperative and competitive characteristics between boreholes, for a certain extrac-

tion time, the cooperative efficiency of gas extraction at a distance  $r$  from a borehole is defined as the ratio between the reduction in gas content extracted by the actual boreholes and the reduction in gas content without considering the interference between boreholes, that is,

$$\eta_r = \begin{cases} 0, & L_z > r_{e1} + r_{e2}, \\ \frac{W_0 - W_r}{\Delta W_1 + \Delta W_2}, & L_z \leq r_{e1} + r_{e2}. \end{cases} \quad (6)$$

**2.2. Calculation Model of Design Parameters.** The flow of gas in the coal body under the action of gas extraction is the result of the coupling of multiple processes such as coal deformation, matrix gas seepage, and fracture air-gas mixing.

- (1) Deformation control equations for dual media coal under ground stress and gas adsorption/desorption stress effects [10]:

$$Gu_{i,kk} + \frac{G}{1-2\nu}u_{k,ki} - \left( \alpha + K \cdot \frac{\varepsilon_L P_L}{(P_L + p_{m1})^2} \right) p_{m1,i} - \beta (p_{f1} + p_{f2})_{,i} + f_i = 0, \quad (7)$$

where  $u_i$  is the displacement component (m),  $G$  is the shear modulus of coal (MPa),  $\nu$  is Poisson's ratio of coal,  $K$  is the bulk modulus of coal (MPa),  $\alpha$  and  $\beta$  are the Biot coefficients of matrix and fracture systems, respectively,  $\varepsilon_L$  is gas Langmuir volumetric strain constant,  $P_L$  is the gas Langmuir pressure constants (MPa),  $f_i$  is the component of physical force (N),  $p_{m1}$  and  $p_{f1}$  are the matrix and fracture gas pressure of the system (MPa), and  $p_{f2}$  is the pressure of the air in the fracture system (MPa)

- (2) Control equations for gas flow transfer in matrix and fracture systems [22]

$$\begin{cases} A \frac{\partial p_{m1}}{\partial t} - \nabla \cdot \left[ \left( \frac{k_m}{\mu} p_{m1} + \varphi_m D_{m1} \right) \nabla p_{m1} \right] = -8 \left( 1 + \frac{2}{a^2} \right) \frac{k_m}{\mu} (p_{m1} - p_{f1}) - B \cdot p_{m1}, \\ \varphi_f \frac{\partial p_{f1}}{\partial t} - \nabla \cdot \left[ \frac{k_f}{\mu} p_{f1} + \varphi_f D_{f1} \right] \nabla p_{f1} = 8 \left( 1 + \frac{2}{a^2} \right) \frac{k_m}{\mu} (p_{m1} - p_{f1}) - C \cdot p_{f1}, \end{cases} \quad (8)$$

where  $p_{m1}$  and  $p_{f1}$  are the gas pressure in the matrix and fracture system, respectively (MPa);  $k_m$  and  $k_f$  are the permeability of the coal matrix and fracture ( $m^2$ );  $\varphi_m$  and  $\varphi_f$  are the porosity of the coal matrix and fracture;  $D_{m1}$  and  $D_{f1}$  are the diffusion coefficients of the matrix and fracture gases ( $m^2/s$ );  $\mu$  is the gas dynamic viscosity coefficient ( $N \cdot s/m^2$ );  $t$  is time (s);  $a$  is the side length of the cubic coal matrix block (m); and the physical expressions of  $A$ ,  $B$ , and  $C$  are

$$\begin{cases} A = \varphi_m + \frac{\rho_s p_a V_L P_L}{(P_L + p_{m1})^2} - \frac{(\varphi_m - \alpha)}{K} \frac{\varepsilon_L P_L p_{m1}}{(P_L + p_{m1})^2} \left( \frac{1}{K} + \frac{b_0}{a_0 K_f} \right)^{-1}, \\ B = \frac{(\varphi_m - \alpha)}{K} \left( \frac{1}{K} + \frac{b_0}{a_0 K_f} \right)^{-1} \frac{\partial \varepsilon_V}{\partial t}, \\ C = \frac{\varphi_{f0}}{K_f} \left( \frac{1}{K} + \frac{b_0}{a_0 K_f} \right)^{-1} \left[ \frac{\partial \varepsilon_V}{\partial t} - \frac{\varepsilon_L P_L}{(P_L + p_{m1})^2} \frac{\partial p_{m1}}{\partial t} \right], \end{cases} \quad (9)$$

where  $\varepsilon_V = \varepsilon_{11} + \varepsilon_{22} + \varepsilon_{33}$  is the volume strain. The subscript, 0, denotes the initial value of the variable

(3) Crack system and air flow control equations [26]:

$$\varphi_f \frac{\partial p_{f2}}{\partial t} - \nabla \cdot \left( \frac{k_f}{\mu} p_{f2} \nabla p_f + \varphi_f D_{f1} \nabla p_{f2} \right) = -C \cdot p_{f2}, \quad (10)$$

where  $p_{f2}$  is the air pressure of the matrix system (MPa)

(4) Cross-coupled variable control equations

The permeability of the coal matrix and fractures can be expressed using the cubic law as [22]

$$\begin{cases} \frac{k_m}{k_{m0}} = \left( \frac{\varphi_m}{\varphi_{m0}} \right)^3, \\ \frac{k_f}{k_{f0}} = \left( \frac{\varphi_f}{\varphi_{f0}} \right)^3. \end{cases} \quad (11)$$

The porosity of the coal matrix and fractures can be expressed as [22]

$$\begin{cases} \varphi_m = \alpha + (\varphi_{m0} - \alpha) \exp \left[ \frac{1}{K} \left( \frac{1}{K} + \frac{b_0}{a_0 K_f} \right)^{-1} (\Delta \varepsilon_V - \Delta \varepsilon_s) \right], \\ \varphi_f = \varphi_{f0} + \frac{\varphi_{f0}}{K_f} \left( \frac{1}{K} + \frac{b_0}{a_0 K_f} \right)^{-1} (\Delta \varepsilon_V - \Delta \varepsilon_s). \end{cases} \quad (12)$$

Equations (7)–(12) comprise a coal gas extraction coupled flow-solid model. Combining equations (1)–(6), the dynamic evolution of coal seam gas flow parameters, gas pressure, and content can be solved, and the borehole coordination and interference characteristics of coal seam prepumping can be revealed, which provides a theoretical basis for the quantitative design of coal seam gas drainage engineering parameters.

**2.3. Optimization of Design Constraints.** Gas extraction is a fundamental measure to manage gas disasters, and its primary purpose is to reduce the pressure and content of coal seam gas; eliminate the risk of coal and gas outburst, gas overrun, gas flare, and other risks in the coal mining process; and realize safe simultaneous extraction of coal and gas. The quantitative design of coal seam gas extraction mainly refers to the quantitative design of engineering parameters such as the borehole diameter  $d$  of gas drainage, the effective extraction length of borehole  $L$ , the negative pressure of borehole  $\Delta p$ , and the borehole spacing  $D$ . The main idea of quantified gas extraction design is to determine the gas prepumping time  $t_0$ , according to the mining succession arrangement first. Then, take the key indicators of gas extraction (gas pressure  $p$ , content  $m$ , and extraction rate  $\eta$ ) and gas extraction concentration  $c$  ( $CH_4$ ) as constraints. At last, based on the mathematical model of gas extraction flow, the most reasonable engineering parameters of coal seam gas extraction (drilling diameter  $d$ , effective extraction length  $L$ , negative pressure  $\Delta p$ , and spacing  $D$ ) are quantitatively determined. Thus, the constraints for the quantitative design of gas extraction engineering parameters are

$$\left. \begin{aligned} c(CH_4) &> c(CH_4)_L \\ m(CH_4) &< m(CH_4)_L \\ p(CH_4) &< p(CH_4)_L \\ \eta &= \frac{Q_{mc}}{Q_{mc} + Q_{mf}} > \eta_L \\ t &= t_0 \end{aligned} \right\} \xrightarrow{S.t(\Delta p, d, L)} \text{Max}(D), \quad (13)$$

where  $c$  is the gas extraction concentration (%),  $m$  is the coal seam gas content ( $m^3/t$ ),  $p$  is the coal matrix gas pressure (Pa),  $\eta$  is the gas extraction rate (%),  $t$  is the gas extraction time (d),  $t_0$  is the gas prepumping time (d), the subscript “L” is the expected minimum target value for extraction,  $S$ .  $t$  is the target constraint, and  $\text{Max}(D)$  is the maximum drilling spacing (m), in which the gas extraction safety meets the standard within the expected period of gas extraction.

**2.4. Solution of Nonlinear Constrained Optimization Problems.** This is a constrained nonlinear programming problem consisting of multifield coupled computational equations, objective function, and constraint equations, which have great complexity. Comsol With Matlab has powerful numerical analysis and nonlinear optimization compilation functions, which provide a powerful computational support platform for solving the optimization problem of equations (1)–(13).

The main purpose of the quantitative design of coal seam gas extraction is to achieve the harmonization of safety and economy and to achieve the maximum arrangement of drilling spacing under the premise of satisfying safety; the basic steps are shown in Figure 2.

- (1) Determine the prepumping time  $t_0$  of the borehole and the minimum borehole spacing  $D_0$  ( $D_{\min}$ ) based on empirical trials.
- (2) The basic parameters of borehole extraction as well as the basic occurrence parameters of coal seam gas are substituted into the multifield coupled calculation model. The values of each parameter are solved when the prepumping time  $t_0$  is reached and to determine whether the constraints are satisfied.
- (3) The conditions for the constraint of the drilling extraction parameters can be determined based on the gas source to meet the parameters and their critical values. If the constraint conditions are met, increase the drilling spacing and continue to calculate according to the second step until the constraint conditions cannot be met.
- (4) If the constraints are not met, a smaller spacing of boreholes is selected to carry out the cycle above.
- (5) Compare the boreholes that meet the borehole drainage constraints in different borehole spacing and determine the maximum gas drainage spacing and output.

### 3. Model Verification and Simulation

**3.1. Model Parameters and Initial Boundary.** The strike length of 8# coal seam in Tunlan 18401 working face is 1760 m, the dip length is 235 m, the average thickness of coal seam is 3 m, the dip angle is  $4^\circ$ , and the average mining depth is 750 m. The original gas content and gas pressure of the coal seam are  $13.4 \text{ m}^3/\text{t}$  and 1.9 MPa, respectively, and the permeability coefficient of the coal seam is  $3.63 \text{ m}^2/(\text{MPa}^2 \cdot \text{d})$ . As shown in Figure 3, the physical model of gas extraction from a three-dimensional hole cluster and its boundary conditions are illustrated. The basic parameters of gas drainage calculation are shown in Table 1.

**3.2. Model Verification and Result Analysis.** Figure 4 shows the distribution of coal seam gas content after 60 days of drilling. It can be seen from the figure that the influence range of gas drainage of the array boreholes gradually extends to the axial center line of the two boreholes and symmetrically distributed on both sides. The gas content at the center line of the two boreholes is the largest, and that at the borehole is the smallest. Extraction volume around single-borehole  $\Delta W_1 = \Delta W_2 = W_0 - W_1 = W_0 - W_2$  is significantly less than the borehole collaborative extraction volume ( $W_0 - W_r$ ), and the superposition effect of two single-borehole extraction ( $\Delta W_1 + \Delta W_2$ ) is greater than the actual extraction content of the borehole extraction ( $W_0 - W_r$ ),

which verifies that there are cooperative and competitive extraction behaviors among boreholes.

Figure 5 shows the field example matching gas drainage results of the single borehole and boreholes. It can be seen from the figure that under the action of gas drainage, the net flow and concentration of borehole gas drainage decay exponentially. The gas flow concentration under borehole drainage can match the actual situation well. Under the single-borehole gas extraction, the pure flow and concentration of gas extracted from the borehole are relatively high for the same simulation conditions, as the hole cluster effect is ignored. Therefore, in the parameter design of on-site gas drainage engineering, the spacing of gas drainage is often too large, and the extraction effect is far from reaching the expected effect. So, it is necessary to fully consider the gas drainage effect of the boreholes to improve the accuracy of parameter design of gas drainage engineering.

### 4. Influencing Factors of Gas Drainage Effect Using Boreholes

#### 4.1. Influence of Borehole Spacing on Drainage Effect.

Figure 6 shows the simulation results of gas drainage using boreholes when the borehole spacing  $D$  is 2 m, 4 m, and 6 m, respectively. It can be seen from the figure that the smaller the borehole spacing, the stronger the competition and synergy between boreholes, the smaller the gas flow and concentration, the faster the attenuation of coal seam gas pressure, and the relatively high gas extraction rate. For example, if the drilling spacing  $D$  is 2 m, the gas flow and extraction rate are  $0.020 \text{ m}^3/\text{min}$  and 37.3%, respectively, after 100 days of extraction, while the gas flow and extraction rate are  $0.028 \text{ m}^3/\text{min}$  and 21.9%, respectively, when  $D$  is 6 m.

#### 4.2. The Influence of Drainage Negative Pressure on Drainage Effect.

Figure 7 shows the simulation results of gas drainage using boreholes when the negative pressure  $\Delta p$  is 13 kPa, 20 kPa, and 25 kPa, respectively. It can be seen from the figure that the negative pressure of extraction has no obvious impact on the competition and synergy between boreholes but has a significant impact on gas drainage concentration. The negative pressure has little effect on the net amount of gas drainage, the change of coal seam gas pressure, and the extraction rate but has a greater impact on the concentration of gas drainage. The greater the negative pressure, the greater the gas leakage of the borehole, resulting in the faster attenuation of the concentration of gas drainage. Such as  $\Delta p = 13 \text{ kPa}$  and  $\Delta p = 25 \text{ kPa}$ , it takes 205.8 days and 152.6 days for gas concentration to decay from the initial state to less than 30%, respectively.

#### 4.3. Influence of Permeability on Drainage Effect.

Figure 8 shows the simulation results of gas drainage using boreholes under different initial permeability of coal matrix  $k_{m0}$  and initial permeability of coal fracture  $k_{f0}$ . It can be seen from the figure that the change in initial permeability of coal matrix  $k_{m0}$  has no significant impact on the competition and synergy between boreholes. While the greater the initial

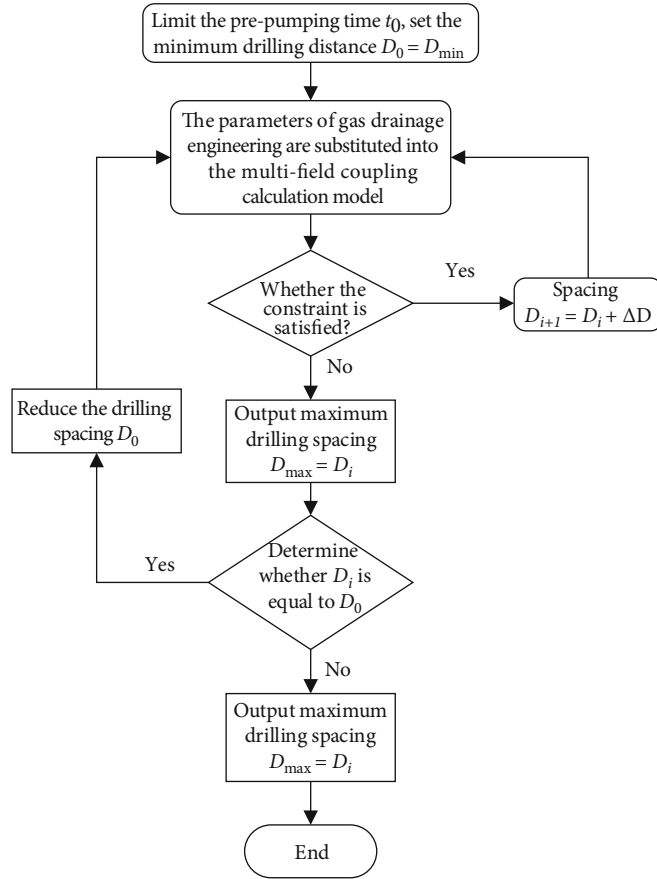
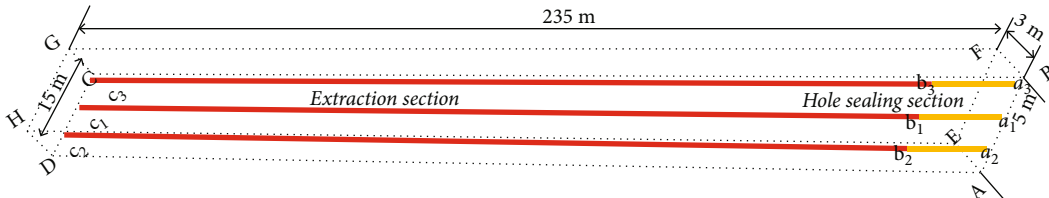

FIGURE 2: Borehole spacing optimization design process.



Geometric parameters:

$$AD = 235 \text{ m}, \quad AB = 15 \text{ m}, \quad BF = 3 \text{ m}, \quad D = 5 \text{ m}, \quad a_1 b_1 = 8 \text{ m}, \quad b_1 c_1 = 222 \text{ m}, \quad r = 56.5 \text{ mm}$$

Boundary and initial conditions:

Condition	Coal deformation		Gas flow		
	Displacement	Stress	Gas	Air	
Initial value	$u_{ij} = 0$	$\sigma_{ij} = 0$	$p_1(0) = 1.9 \text{ MPa}$	$p_1(0) = 0 \text{ MPa}$	
Boundary conditions	ABEF	$u_x = u_y = 0$	$\sigma_{ij} = 0$	$p_1 = 1 \text{ atm}$	$p_2 = 1 \text{ atm}$
	EFGH	$u_x = u_y = 0$	$\sigma_z = -5 \text{ MPa}$	No seepage	No seepage
	ABCD	$u_{ii} = 0$	$\sigma_{ij} = 0$	No seepage	No seepage
	AEHD HDCG BFGC	$u_x = u_y = 0$	$\sigma_{ij} = 0$	Symmetric	Symmetric
	$a_i b_i$	$u_{ii} = 0$	$\sigma_{ij} = 0$	No seepage	No seepage
	$b_i c_i$	$u_{ii} = 0$	$\sigma_{ij} = 0$	$p_1 = 1 \text{ atm} - 13 \text{ kPa}$	$p_1 = 1 \text{ atm} - 13 \text{ kPa}$ or $-n \cdot (-\frac{k}{\mu} \nabla p_2) = N_0$

FIGURE 3: Schematic diagram of numerical model of gas extraction borehole.

TABLE 1: Basic parameters of gas extraction simulation.

Parameter	Value	Parameter	Value
Young's modulus of coal ( $E$ , MPa)	2813	Initial permeability of coal fracture ( $k_{f0}$ , $m^2$ )	$4.0 \times 10^{-18}$
Young's modulus of coal grains ( $E_s$ , MPa)	8439	Normal atmospheric pressure ( $p_a$ , MPa)	0.101325
Fracture strength of coal ( $K_n$ , MPa)	4800	Langmuir pressure constant ( $P_L$ , MPa)	0.922
Poisson's ratio of coal ( $\nu$ )	0.339	Langmuir volume constant ( $V_L$ , $m^3/kg$ )	0.023
Density of coal ( $\rho_s$ , $kg/m^3$ )	1250	Langmuir volumetric strain constant ( $\epsilon_L$ )	0.01266
Initial porosity of the coal matrix ( $\varphi_m$ )	0.05	Dynamic viscosity of methane ( $\mu$ , $N \cdot s/m^2$ )	$1.84 \times 10^{-5}$
Initial permeability of coal matrix ( $k_{m0}$ , $m^2$ )	$8.9 \times 10^{-20}$	Density of methane at standard condition ( $\rho_s$ , $kg/m^3$ )	0.717
Initial gas pressure of coal seam ( $p_0$ , MPa)	1.9	Air leakage ( $N_0$ , $m/s$ )	$4 \times 10^{-4}$

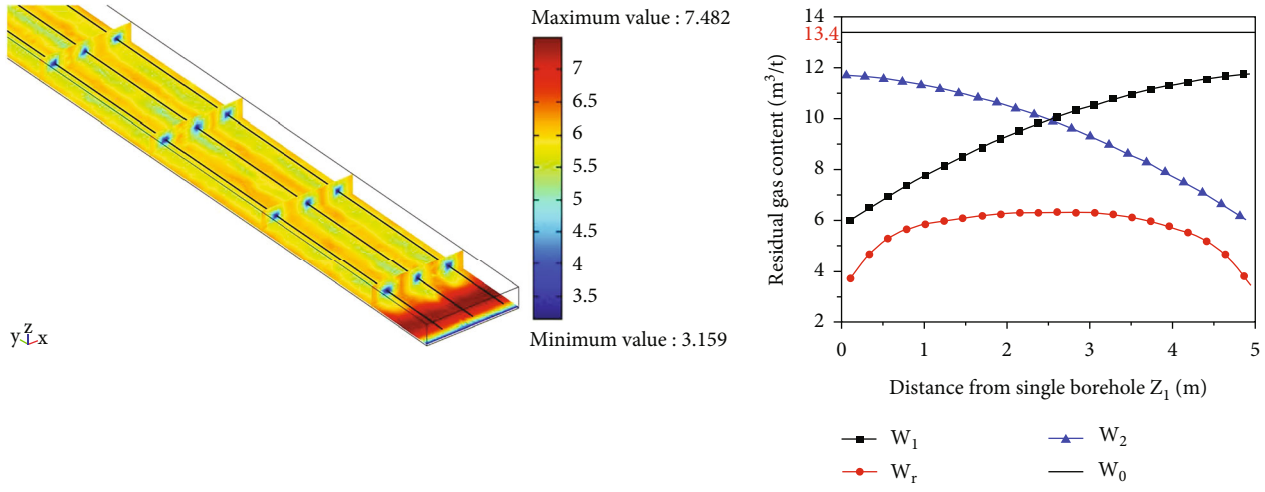

FIGURE 4: The gas content distribution of coal seam extracted by the boreholes.

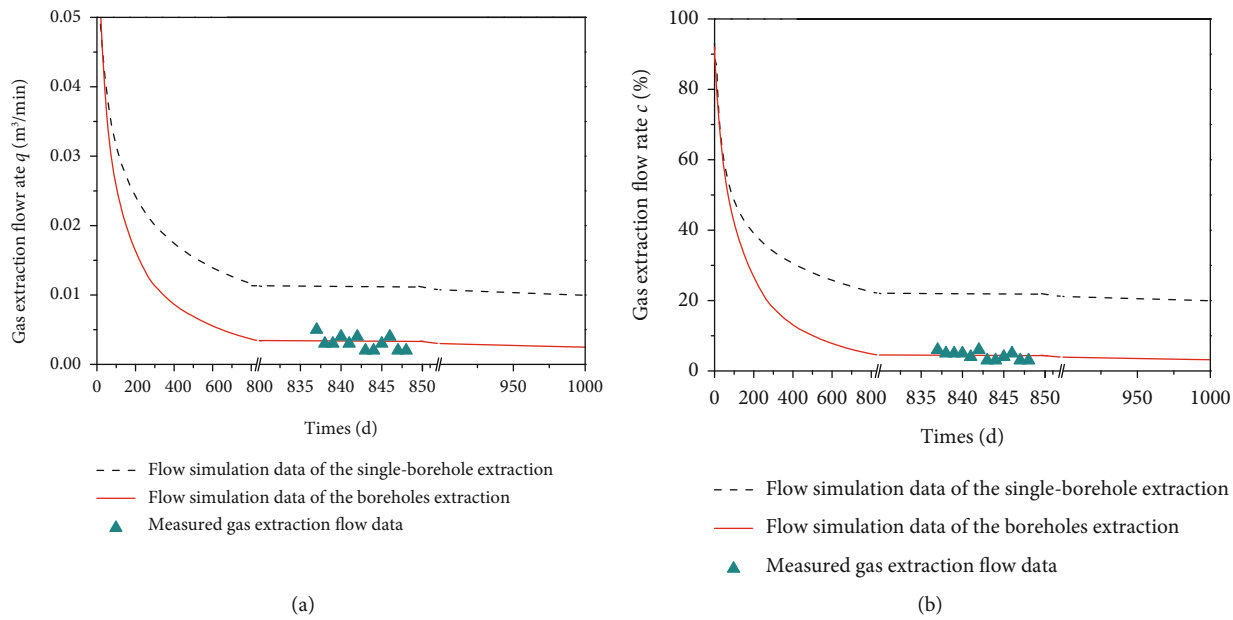

FIGURE 5: Matching gas drainage results of the single borehole and boreholes in the field.

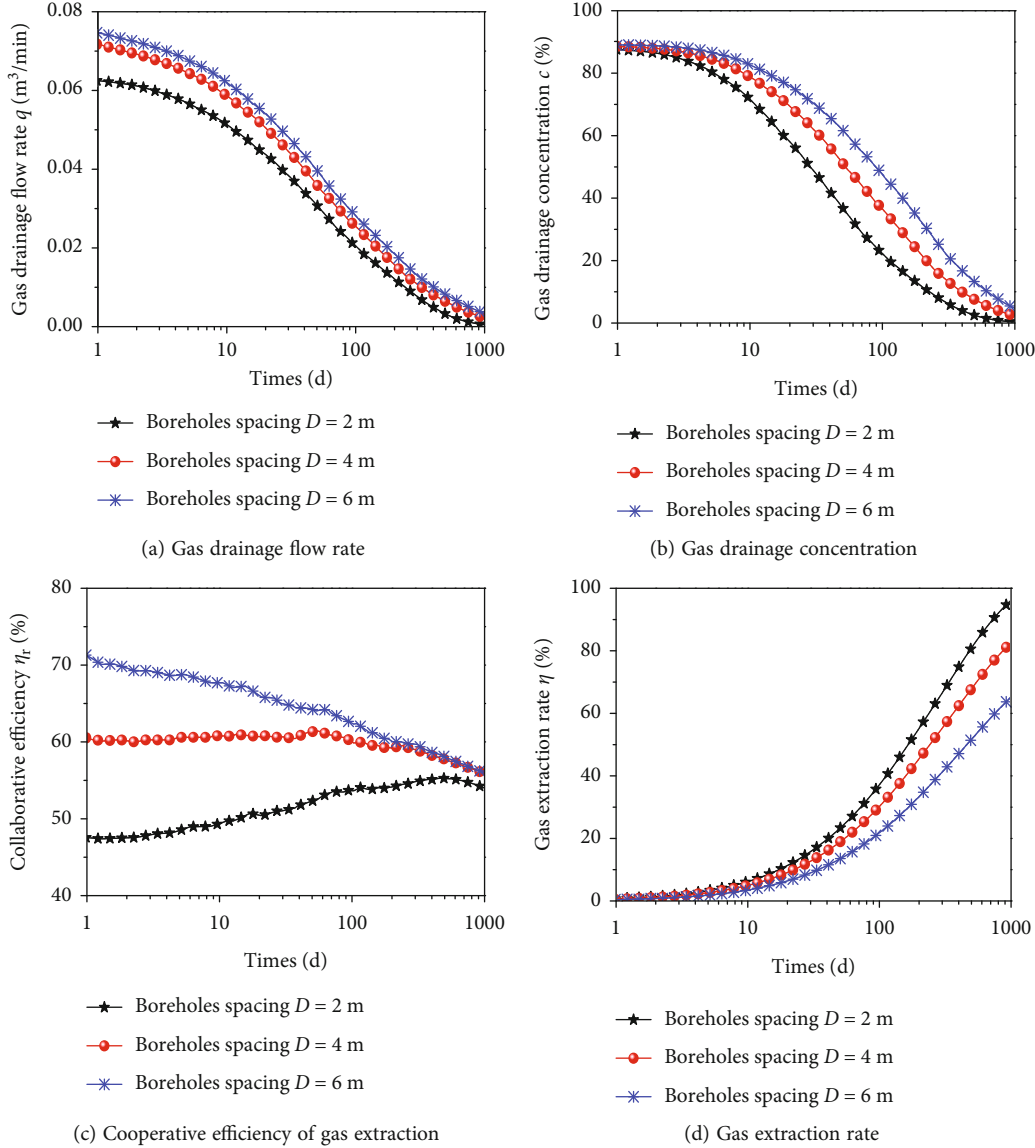

FIGURE 6: The influence of the borehole spacing on gas drainage effect.

fracture permeability  $k_{f0}$ , the stronger the gas migration capacity of the fracture system, the stronger the competition effect between boreholes, the higher the purity and concentration of gas drainage, and the greater the gas drainage rate. For example, when the initial permeability of the coal matrix is the same value ( $k_{m0} = 8.9 \times 10^{-20} \text{ m}^2$ ), within 100 days of gas drainage time, the corresponding gas extraction rates of different coal fracture initial permeability  $k_{f0} = 4.0 \times 10^{-18}$  and  $k_{f0} = 4.0 \times 10^{-17}$  are 20.2% and 45.8%, respectively. Under the same extraction time and the same coal fracture initial permeability  $k_{f0} = 8.9 \times 10^{-18} \text{ m}^2$ , the extraction rates of different coal matrix initial permeability  $k_{m0} = 4.0 \times 10^{-20}$  and  $k_{m0} = 4.0 \times 10^{-19} \text{ m}^2$  are 20.2% and 20.4%, respectively. This shows that the transmission of gas in the coal seam is mainly determined by the fracture system, and the matrix system mainly determines the diffusion process of coal,

which has no obvious effect on the improvement of gas transmission capacity.

## 5. The Influence of Gas Adsorption Characteristics on Drainage Effect

Figure 9 shows the simulation results of gas drainage using borehole pumping with different volume constants  $V_L$  and pressure constants  $P_L$ . It can be seen from the figure that the gas adsorption constant of coal has a significant impact on the competition and synergy between boreholes. The smaller the pressure constant  $P_L$  and the larger the volume constant  $V_L$ , the higher the net amount and concentration of gas drainage, the faster the attenuation rate of coal seam gas pressure, and the greater the gas drainage rate. For example, when the volume constant  $V_L$  is  $0.023 \text{ m}^3/\text{kg}$ , the



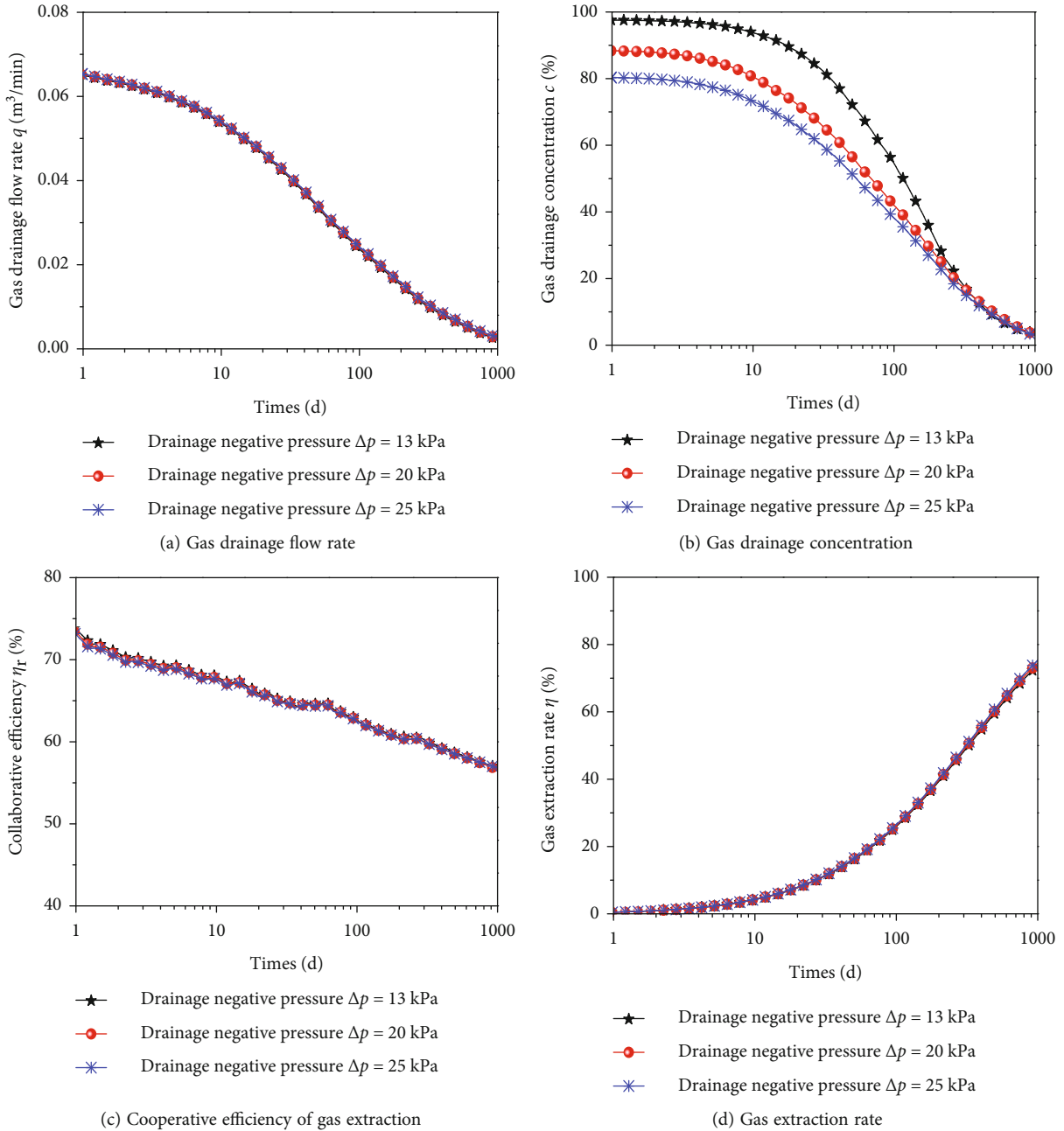

FIGURE 7: Influence of different negative pressure on gas drainage effect.

corresponding drainage gas flow of different pressure constants  $P_L$  is 0.922 MPa and 6.922 MPa for 60 days is 0.0322 and 0.0171  $m^3/min$ , respectively. The corresponding gas drainage flow of different volume constants  $V_L = 0.023$  and 0.043  $m^3/kg$  is 0.0322 and 0.0443  $m^3/min$ , respectively.

### 6. Example of Optimized Design of Gas Drainage

The coal seam structure of 18401 in Tulan coal mine is complex, and there is a risk of coal and gas protrusion. In order to prevent the occurrence of gas overrun accidents during backstopping, gas extraction and management measures

must be used to ensure the safe production of the working face. According to the working face drainage standard conditions, the residual gas pressure  $p(CH_4)_L$  should be lower than 0.74 MPa, the residual gas content  $m(CH_4)_L$  should be lower than 8  $m^3/t$ , and the gas extraction rate  $\eta$  should be higher than 40% are selected as the target constraints of the parameters. In the design of the drill hole spacing for the 18401 working face, the range of drill hole spacing  $D$  is calculated from 2 m to 6 m, the calculation time  $t_0$  is 900 days, the initial spacing  $D_0$  is 2 m, and the calculation step is 1 m. At each calculation step, the software automatically judges whether the extraction index meets the standard according to the calculation result until the end, and the

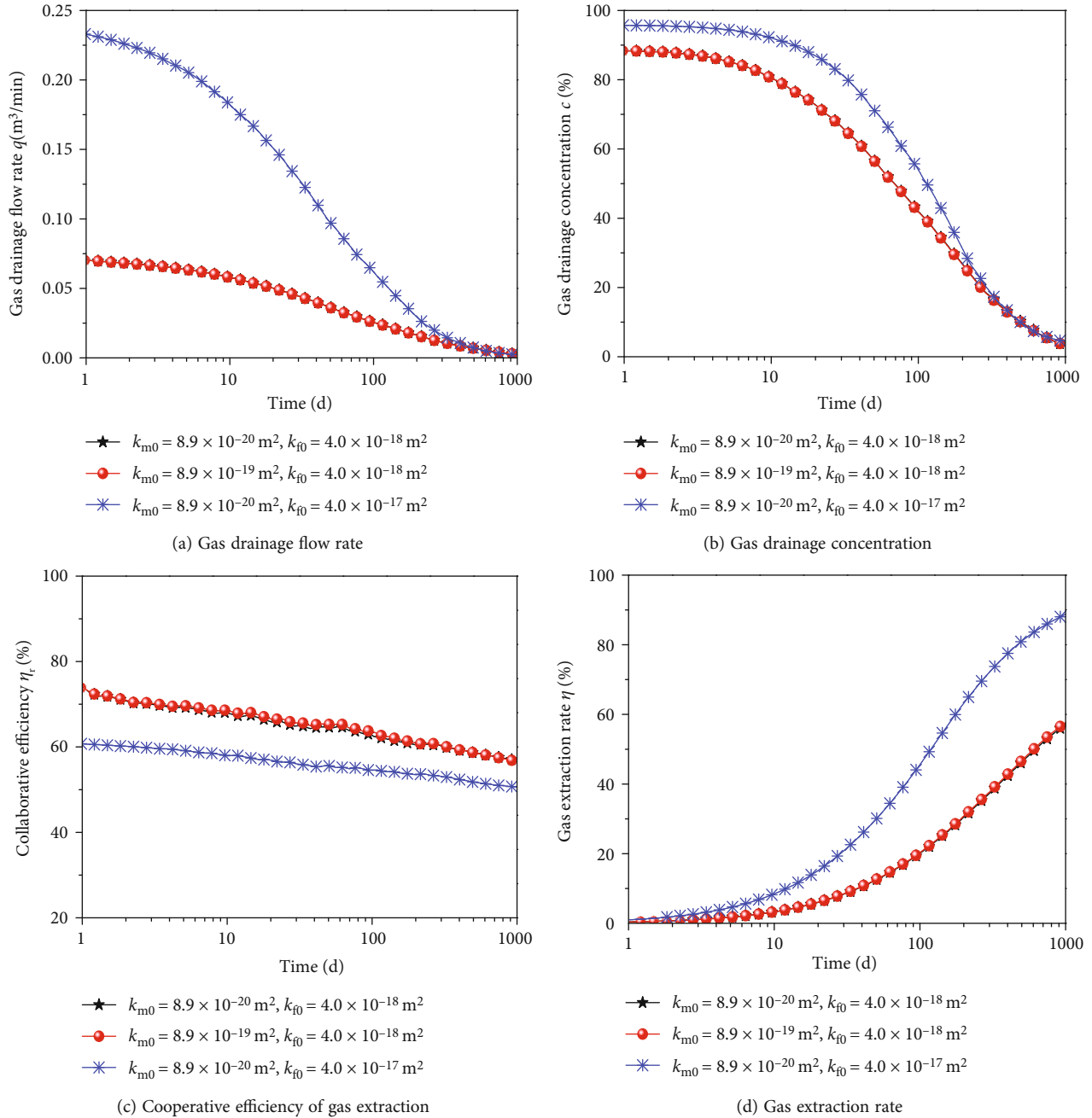

FIGURE 8: Influence of different permeability of coal seam on gas drainage effect.

maximum drill hole spacing  $D$  that meets all indexes is preferably selected from the range of drill hole spacing. The simulation results of different drill hole spacing are shown in Table 2.

According to the simulation prediction results in Table 2, the residual gas content and gas extraction rate of coal can no longer meet the extraction target when the drill hole spacing is greater than 6 m, and the maximum drill hole spacing to meet all constraints is 5 m. Therefore, in order to ensure the safe production of mine, the drill hole spacing should be less than 5 m when designing drill holes. In consideration of the actual excavation schedule of the working face, the drilling spacing inward the second setup room of

the track roadway and at 765 m inward from the alley entrance of the air-return measure roadway of the belt roadway are designed according to 3 m, and it is designed as 5 m at 38 m inward from the alley entrance of the return air measures of track roadway. The specific layout is shown in Figure 10 and Table 3.

Figure 11 shows the gas extraction data of 18401 working face during 2017.06.07~2017.12.31. From the figure, it can be seen that the cumulative volume of gas extraction in the track roadway is 2,709,400 m<sup>3</sup>, the average pure volume of extraction is 9.32 m<sup>3</sup>/min, and the average extraction concentration is 31.53%; the cumulative volume of gas extraction in the belt roadway is 205,100 m<sup>3</sup>, the average

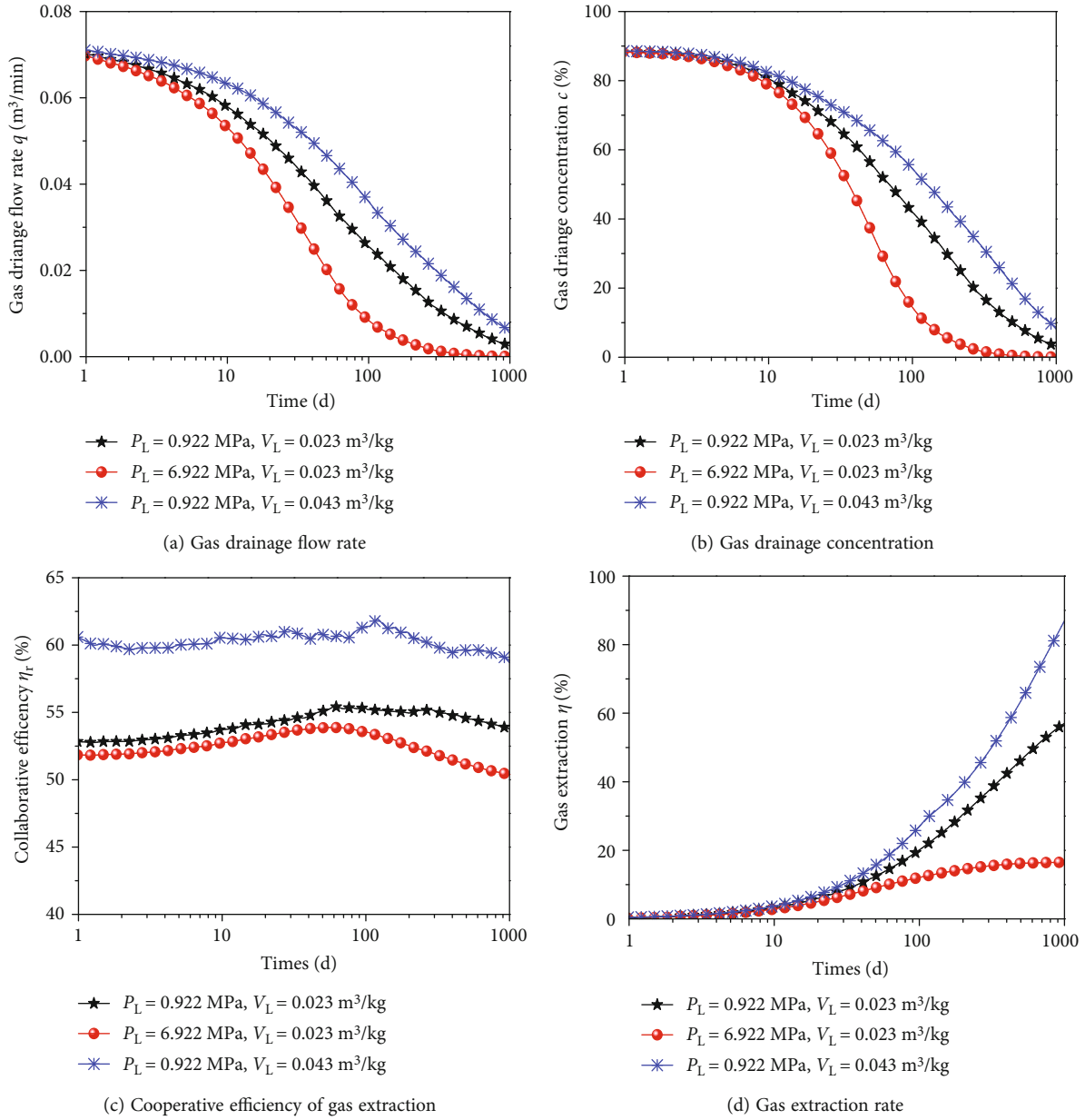

FIGURE 9: Influence of gas adsorption constant on gas extraction effect.

TABLE 2: Prediction of gas drainage effect at different spacing of boreholes.

Index	Expected value	Borehole spacing				
		2 m Predicted value	3 m Predicted value	4 m Predicted value	5 m Predicted value	6 m Predicted value
Residual gas volume (m <sup>3</sup> /t)	<8	4.38	6.14	6.99	7.76	8.66
Gas extraction rate (%)	>40	67.3	54.2	47.8	42.1	35.4
Maximum coal matrix gas pressure (MPa)	<0.74	0.097	0.119	0.136	0.152	0.169
Are all constraints met?		✓	✓	✓	✓	✓

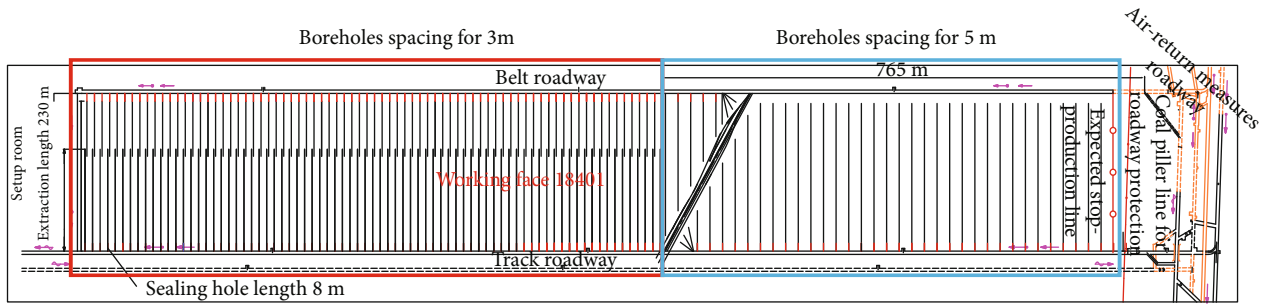

FIGURE 10: Extracting seam drilling construction layout.

TABLE 3: Parameters of the extracting seam drilling construction layout.

	Location	Hole depth	Dip angle	Position	Aperture	Number of boreholes	Total footage	Opening height	Spacing
Track roadway	Air-return measure roadway 38 meters inward	220 m	1~2°	90°	113 mm	118	25960 m	1.5 m	5 m
	Inward from the second setup room	150 m	1~2°	90°	113 mm	307	46050 m	1.5 m	3 m
Belt roadway	Air-return measure roadway 765 meters inward	90 m	-1~-2°	90°	113 mm	307	27630 m	1.5 m	3 m

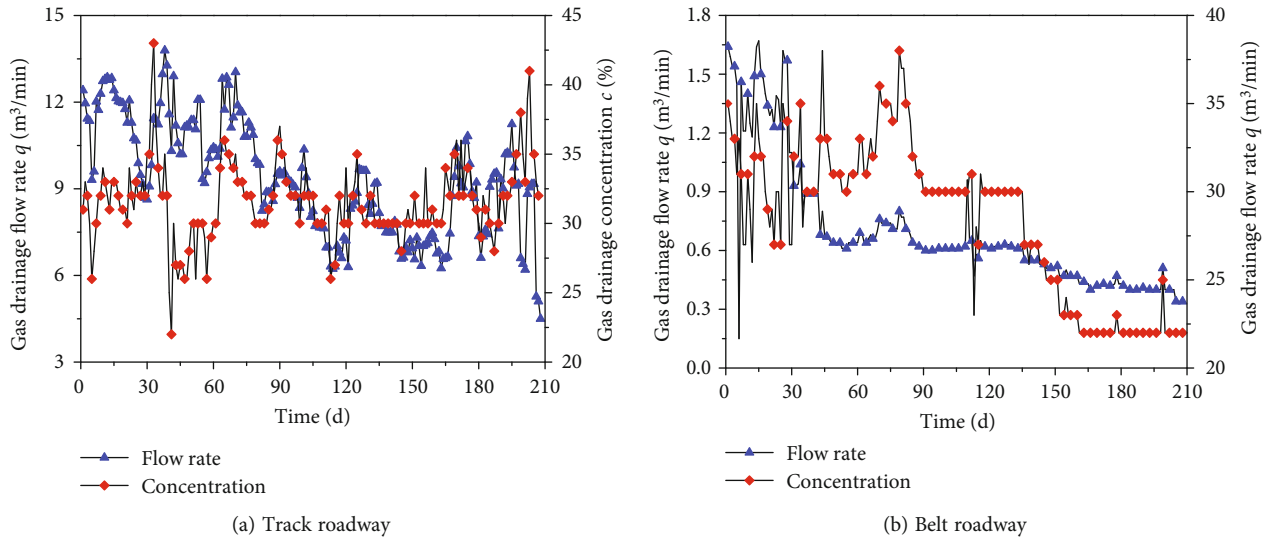

FIGURE 11: Variation of gas flow and concentration in track and belt roadway systems.

pure volume of extraction is  $0.69 \text{ m}^3/\text{min}$ , and the average extraction concentration is 28.24%. After extraction, the coal seam gas content of 18401 working face is obviously reduced, and the extraction effect is relatively satisfactory.

### 7. Conclusions

In this study, the governing equation of coal seam content evolution under the cooperative-competition of gas extraction by the boreholes was established, the calculation formula of gas cooperative efficiency was defined, and the cooperative and competitive behavior of gas extraction by the boreholes was revealed. The results show that drilling

spacing, seam fracture permeability, and gas adsorption constant have significant effects on the synergistic and competitive effects of the boreholes, while the negative pressure of gas extraction and coal matrix permeability have little effects. But the negative pressure of gas extraction has great effects on gas extraction concentration.

A multifield coupling 3d model of coal seam extraction of the boreholes was developed based on gas-air mixed flow developed. In the model, we put forward the content, method, and principle of the parameter design of the optimal borehole drainage spacing and constructed the constraint conditions and objective function of the parameter optimization design of gas drainage engineering. It provides

a theoretical basis for the quantitative design of coal seam gas drainage engineering parameters.

Comsol With Matlab was used to solve the multiconstraint nonlinear optimization problem of gas extraction engineering parameters along the coal seam group in 18401 working face of Tunlan Mine, and the optimal drilling layout parameters were determined. From July 6, 2017, to December 31, 2017, the cumulative capacity of gas extracted by the extraction system of track roadway and belt roadway was 2,709,400 m<sup>3</sup> and 205,100 m<sup>3</sup>, respectively, which has achieved an ideal drainage effect.

## Data Availability

The data used to support the findings of this study are available from the corresponding author upon request.

## Conflicts of Interest

The authors declare that they have no conflicts of interest.

## Acknowledgments

This work was supported by the National Natural Science Foundation of China (52074284), Local Science and Technology Development Fund project guided by Central Government of Shanxi Province (YDZJSX2921B021), Open Fund of State Key Laboratory of Oil and Gas Reservoir Geology and Exploitation in Chengdu University of Technology (PLC20210301), Open Fund of State Key Laboratory of Coal Resources in Western China (SKLCRKF20-12), and Open Sharing Fund for the Large-scale Instruments and Equipments of China University of Mining and Technology (DYGX-2021-008).

## References

- [1] L. Yuan, "Strategic thinking of simultaneous exploitation of coal and gas in deep mining," *Journal of China Coal Society*, vol. 41, no. 1, pp. 1–6, 2016.
- [2] G. Si and B. Belle, "Performance analysis of vertical goaf gas drainage holes using gas indicators in Australian coal mines," *International Journal of Coal Geology*, vol. 216, article 103301, 2019.
- [3] G. Si, S. Durucan, J. Shi, A. Korre, and W. Cao, "Parametric analysis of slotting operation induced failure zones to stimulate low permeability coal seams," *Rock Mechanics and Rock Engineering*, vol. 52, no. 1, pp. 163–182, 2019.
- [4] X. Xie, G. Fu, Y. Xue et al., "Risk prediction and factors risk analysis based on IFOA-GRNN and apriori algorithms: application of artificial intelligence in accident prevention," *Process Safety and Environmental Protection*, vol. 122, pp. 169–184, 2019.
- [5] F. Zhou, T. Xia, X. Wang, Y. Zhang, Y. Sun, and J. Liu, "Recent developments in coal mine methane extraction and utilization in China: a review," *Journal of Natural Gas Science and Engineering*, vol. 31, pp. 437–458, 2016.
- [6] T. Liu, B. Lin, X. Fu, and C. Zhu, "Modeling air leakage around gas extraction boreholes in mining-disturbed coal seams," *Process Safety and Environmental Protection*, vol. 141, pp. 202–214, 2020.
- [7] H. Zhai and J. Linghu, "Practice and innovation mode of gas control in Yangquan Mining Area," *Coal Science and Technology*, vol. 46, no. 2, pp. 168–175, 2018.
- [8] H. Zhou, "Dynamic evaluation method for the effect of gas extraction," *Safety in Coal Mines*, vol. 46, no. 11, pp. 164–167, 2015.
- [9] W. Zhu, C. Wei, J. Liu, H. Y. Qu, and D. Elsworth, "A model of coal-gas interaction under variable temperatures," *International Journal of Coal Geology*, vol. 86, no. 2-3, pp. 213–221, 2011.
- [10] T. Xia, F. Zhou, J. Liu, and J. Wang, "Simulation of coal self-heating processes in underground methane-rich coal seams," *International Journal of Coal Geology*, vol. 141-142, pp. 1–12, 2015.
- [11] W. Cao, J. Shi, S. Durucan, G. Si, and A. Korre, "Gas-driven rapid fracture propagation under unloading conditions in coal and gas outbursts," *International Journal of Rock Mechanics and Mining Sciences*, vol. 130, article 104325, 2020.
- [12] Y. Xue, J. Liu, X. Liang, S. Wang, and Z. Ma, "Ecological risk assessment of soil and water loss by thermal enhanced methane recovery: numerical study using two-phase flow simulation," *Journal of Cleaner Production*, vol. 334, article 130183, 2022.
- [13] Y. Xue, J. Liu, P. G. Ranjith, Z. Zhang, F. Gao, and S. Wang, "Experimental investigation on the nonlinear characteristics of energy evolution and failure characteristics of coal under different gas pressures," *Bulletin of Engineering Geology and the Environment*, vol. 81, no. 1, pp. 1–26, 2022.
- [14] T. H. Yang, S. K. Chen, W. C. Zhu, H. L. Liu, Z. G. Huo, and W. Z. Jiang, "Coupled model of gas-solid in coal seams based on dynamic process of pressure relief and gas drainage," *Rock and Soil Mechanics*, vol. 31, no. 7, pp. 2247–2252, 2010.
- [15] Y. Lu, H. Shen, B. Qin, L. Zhang, H. Ma, and T. Mao, "Gas drainage radius and borehole distance along seam," *Journal of Mining and Safety Engineering*, vol. 32, no. 1, p. 156, 2015.
- [16] R. Li, B. Liang, W. Sun, X. Li, and D. Liu, "Experimental study on both gas drainage radius and bedding borehole space," *China Safety Science Journal*, vol. 26, no. 10, pp. 133–138, 2016.
- [17] H. Guo, H. Tang, K. Wang et al., "Application of gas-solid coupling effect in the gas drainage with double boreholes along coal seam," *Journal of Xi'an University of Science and Technology*, vol. 41, no. 2, pp. 221–229, 2021.
- [18] G. Hu, J. Xu, H. Wang, Z. Jin, and R. Wu, "Research on a dynamically coupled deformation and gas flow model applied to low-permeability coal," *Journal of China University of Mining & Technology*, vol. 40, no. 1, pp. 1–6, 2011.
- [19] H. Wang, J. Jiang, and Z. Wang, "Numerical simulation of seepage field of gas extraction drilling of single bedding of mining-coal bed," *Journal of Chongqing University*, vol. 34, no. 4, pp. 24–29, 2011.
- [20] F. Hao, M. Liu, and L. Sun, "Determination method of gas drainage radius based on multi-physics coupling," *Journal of China Coal Society*, vol. 38, no. S1, pp. 106–111, 2013.
- [21] B. Liang, X. Yuan, and W. Sun, "Seepage coupling model of in-seam gas extraction and its applications," *Journal of China University of Mining & Technology*, vol. 43, no. 2, pp. 208–213, 2014.
- [22] T. Xia, F. Zhou, J. Liu, and F. Gao, "Evaluation of the pre-drained coal seam gas quality," *Fuel*, vol. 130, pp. 296–305, 2014.

- [23] X. Men, S. Tao, Z. Liu, W. Tian, and S. Chen, "Experimental study on gas mass transfer process in a heterogeneous coal reservoir," *Fuel Processing Technology*, vol. 216, article 106779, 2021.
- [24] J. Liu, Z. Chen, D. Elsworth, H. Qu, and D. Chen, "Interactions of multiple processes during CBM extraction: a critical review," *International Journal of Coal Geology*, vol. 87, no. 3-4, pp. 175-189, 2011.
- [25] C. Shu, H. T. Wang, M. Q. Ren, F. Shi, and G. Z. Hu, "Model of effective borehole gas drainage radius based on volume of gas drainage and its engineering verification," *Journal of Mining & Safety Engineering*, vol. 34, pp. 1011-1026, 2017.
- [26] T. Xia, F. Zhou, J. Liu, S. Hu, and Y. Liu, "A fully coupled coal deformation and compositional flow model for the control of the pre-mining coal seam gas extraction," *International Journal of Rock Mechanics & Mining Sciences*, vol. 72, pp. 138-148, 2014.