

Research Article

Study on the Inerting Effect and Migration Law of Nitrogen and Carbon Dioxide in Large Inclined Goaf by Physical Simulation Model

Xiaolin Song,^{1,2} Chunlei Wu ,^{1,2} Chun Liu,³ Yanlong Li,^{1,2} Zhiyu Wang,^{1,2} and Bobo Shi ^{1,2}

¹State Key Laboratory of Coal Resources and Safe Mining, China University of Mining and Technology, Xuzhou, Jiangsu 221116, China

²School of Safety Engineering, China University of Mining and Technology, Xuzhou, Jiangsu 221116, China

³IoT Perception Mine Research Center, China University of Mining and Technology, Xuzhou 221116, China

Correspondence should be addressed to Chunlei Wu; tb18120020b1@cumt.edu.cn and Bobo Shi; shibobo@cumt.edu.cn

Received 24 July 2021; Revised 28 June 2022; Accepted 22 July 2022; Published 31 August 2022

Academic Editor: E. Santoyo

Copyright © 2022 Xiaolin Song et al. This is an open access article distributed under the Creative Commons Attribution License, which permits unrestricted use, distribution, and reproduction in any medium, provided the original work is properly cited.

In this paper, the inerting effect and migration law of inert N₂ and CO₂ in large inclined goaf are studied using a physical simulation model. The differences in oxygen reduction and inert gas migration are analyzed and compared. The results show that as N₂ and CO₂ injection increased, the oxidation zone's range and width shrunk, and the end of the loose and oxidation zones moved closer to the working face. The migration profile of CO₂ and N₂ resembled a trumpet and an L shape, respectively, and under the same inerting flow rate, the effect of CO₂ inerting on oxygen reduction was much less significant than that of N₂.

1. Introduction

Steeply dipping coal seams with dip angles of 35° to 55° are considered challenging to mine internationally. Currently, coal reserves of steeply dipping coal seams account for about 20% of the total coal reserves in China [1], and its annual production accounts for about 10% of total coal production. With continuous mining, coal seams with good occurrence conditions in the eastern region are gradually exhausted. As a result, the coal mining center shifts to the western region, and the proportion of mined steeply dipping coal seams continues to increase [2]. However, spontaneous combustion, one of the major disasters in coal mine production, has become a major hindering factor of green, efficient, high-yield, and safe coal production in China. Spontaneous combustion causes secondary disasters such as gas explosions, coal dust explosions, and the release of toxic gases that seriously threaten the safety of miners and the profit of the mines. It is reported that over half of the coal mines in China are at risk of spontaneous combustion, 60% of which are

caused by fires in goafs [3]. However, mining large dip angle coal seams is easier to spontaneously combust than mining near horizontal coal seams. The mining methods of large dip angle coal seams mainly include horizontal slicing mining, roadway caving mining method, segmentalized horizontal slicing or oblique cutting slicing mining, pseudoinclined strike long wall caving mining, and so on [4]. The particularities of the coal mining methods could cause severe floating coal accumulation and asymmetric distribution in goafs, which increases the risk of spontaneous combustion [5]. Therefore, preventing floating coal spontaneous combustion in the goaf of steeply dipping working face is crucial for safe coal mine production.

Among the many fire prevention technologies reported, inert gas fire prevention technology has significant advantages due to its rapid oxygen, temperature, and air leakage reduction in goafs [6]. The inert gases adopted are mainly N₂ and CO₂. Inert gas fire prevention and fire extinguishing technologies in slightly inclined coal seams have been

TABLE 1: Basic parameters of the similar simulation experiment platform for goaf of high inclined working face.

| Element | Conventional value | Simulated value | Element | Conventional value | Simulated value |
|-----------------------------|--------------------|-----------------|------------------------------|--------------------|-----------------|
| The working face length (m) | 126 | 2 | The caving zone height (m) | 12~21 | 0.2~0.33 |
| The gob model length (m) | 180 | 3 | The fracture zone height (m) | 39~48 | 0.67 |
| The gob model height (m) | 60 | 1 | Inclination angle (°) | 45 | 45 |

systematically studied. Chen and Wang [7] studied the law of spontaneous combustion in the goaf of comprehensive caving working face and the nitrogen injection technology to prevent and extinguish fires, concluding that the risk of spontaneous combustion in the goaf of comprehensive caving working face at a certain height could be eliminated with nitrogen injection. Zhuang et al. [8] investigated the mechanism of spontaneous combustion in the goaf of working face during the layered mining of thick coal seams and put forward the isolation nitrogen injection technology with optimal nitrogen injection parameters. Zheng [9] studied the mechanism and parameters of nitrogen injection to prevent and extinguish fires in goafs under different mining conditions.

Domestic and foreign scholars have carried out a lot of research work on the migration of N_2 and CO_2 in goaf. Cao et al. [10] analyzed the influence of nitrogen injection flow rate in the goaf on the nitrogen migration radius based on field measured data, concluding that increasing the nitrogen injection flow rate could increase the nitrogen migration radius in a nearly linear logarithmic form. But with the increase of nitrogen injection flow rate, the oxygen suppression efficiency of nitrogen injection to the oxidation zone in the goaf decreases gradually, so simply increasing nitrogen injection flow rate will not have an ideal effect. Cao et al. [11] studied the range of changes in the three spontaneous combustion zones before and after nitrogen injection through on-site monitoring and determined the optimal position and flow rate of nitrogen injection for the optimal inerting effect. Shao et al. [12, 13] studied the flow characteristics of CO_2 in the goaf through numerical simulation and concluded that injecting CO_2 into the goaf is more effective than injecting nitrogen. Wang et al. [14] adopted numerical test methods to study the distribution law of the three spontaneous combustion zones in the goaf of a fully mechanized working face with different positions and flow rates of carbon dioxide injection. Their results showed that the optimal carbon dioxide injection position is the inlet groove about 20 m from the working face, and the maximum width of the oxidation heating zone after carbon dioxide injection moves from the inlet side to the middle of the working face.

According to the literature review, scholars have conducted relatively little research on the migration law of inert gas in the goaf of the high-inclination working face, especially the goaf with complex coal and rock distribution under slicing mining in high-inclination thick coal seams. Therefore, effectively predicting the inert gas flow in the

goaf of the high-inclination thick coal seam under slicing mining and accurately implementing the fire prevention technology is of top priority in preventing and controlling spontaneous combustion in the goaf. This paper takes the Dongxia coal mine as the research object and conducts physical similarity simulation experiments to study the O_2 distribution and inert gas migration law in the goaf after inert gas injection. This study could guide fire prevention in mines and have important practical significance for preventing and controlling spontaneous combustion in goafs of large inclined coal seams.

2. Materials and Methods

2.1. Overview of 37121-1 Working Face. The 37121-1 working face with a large dip angle in the Dongxia coal mine is located in the 940-875 stage of the Dongxia coal mine. The average thickness of the coal seam in this face is 7.0 m, and the average dip angle of the working face is 45°. This coal seam has a high risk of spontaneous combustion with the smallest spontaneous combustion duration of 37 days. The working face's strike length is 1021 m, and the inclination length is 126 m. The comprehensive mechanized top coal caving mining method is adopted for mining, with a mining height of 2.7 m and a caving height of 4.3 m. The working face is set up at a level between +940 m and +875 m. The design air supply of the working face is 490 m^3/min , whereas the actual air supply is 750 m^3/min .

2.2. Experimental Platform

2.2.1. Experimental Platform Design. To investigate the effects of inert gas injection settings on O_2 distribution in large inclined goaf, a similarity simulation experiment platform based on working face 37121-1 in the Dongxia coal mine (similar ratio, 1:60) was established. The basic parameters of the similarity simulation experiment platform are shown in Table 1.

The similarity simulation experiment follows three similarity criteria: geometric similarity, kinematic similarity, and dynamic similarity, as shown below [15–17].

- (i) *Geometric similarity:* the similarity simulation experiment platform for goafs of high inclined working faces is proportional to the geometric parameters of the real goafs. The foam used to fill the goaf in the simulation is proportional to the size of the gravel in the real goaf
- (ii) *Kinematic similarity:* the time for the air to flow through the working face in the similarity

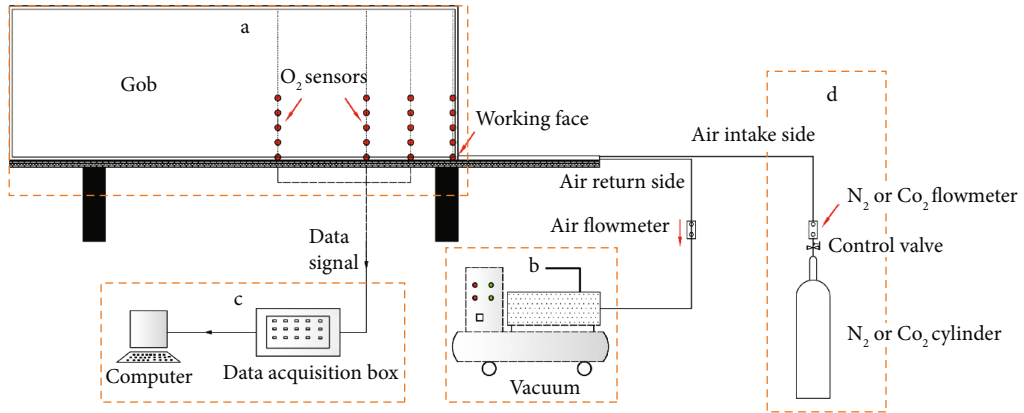

FIGURE 1: Schematic diagram of the experimental platform.

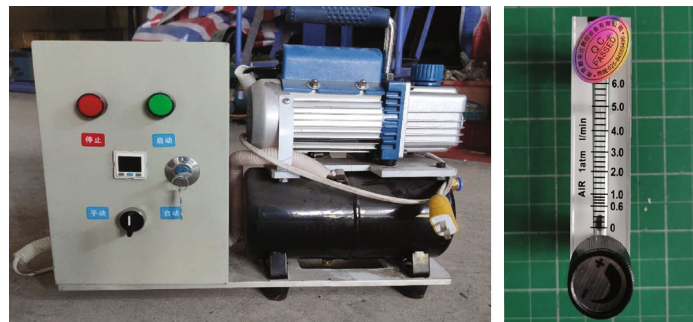

FIGURE 2: The negative pressure vacuum pump and rotameter.

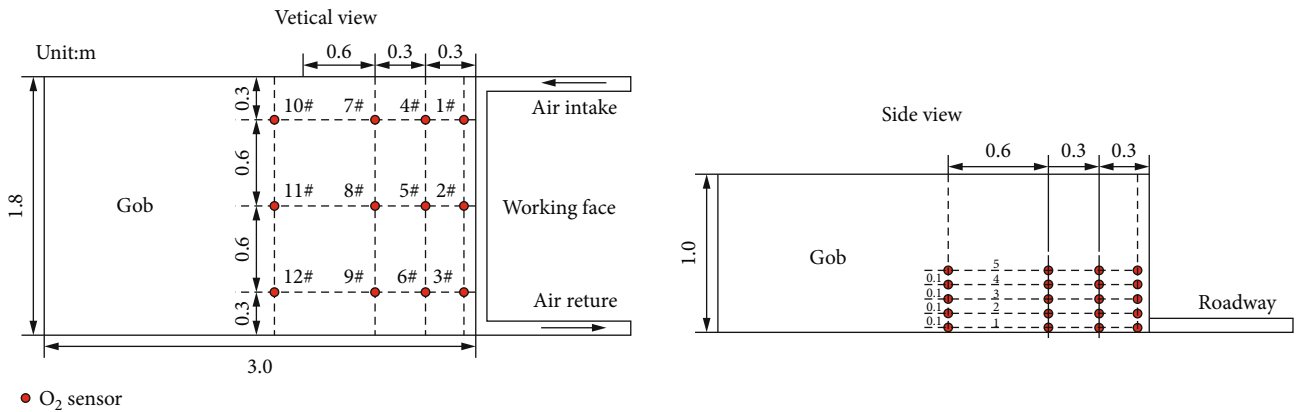

FIGURE 3: The layout of O₂ sensors.

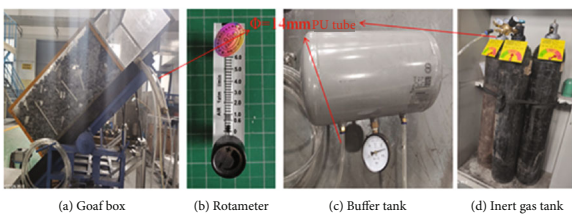

FIGURE 4: The N₂ and CO₂ injection system.

TABLE 2: The similarity simulation experiment scheme.

| Inert | Inclination angle (°) | Depth of buried pipe (m) | Ventilation rate (L/min) |
|---------------------------------|-----------------------|--------------------------|--------------------------|
| | | | 1.1 |
| N ₂ /CO ₂ | 45° | 0.67 | 2.3 |
| | | | 3.4 |

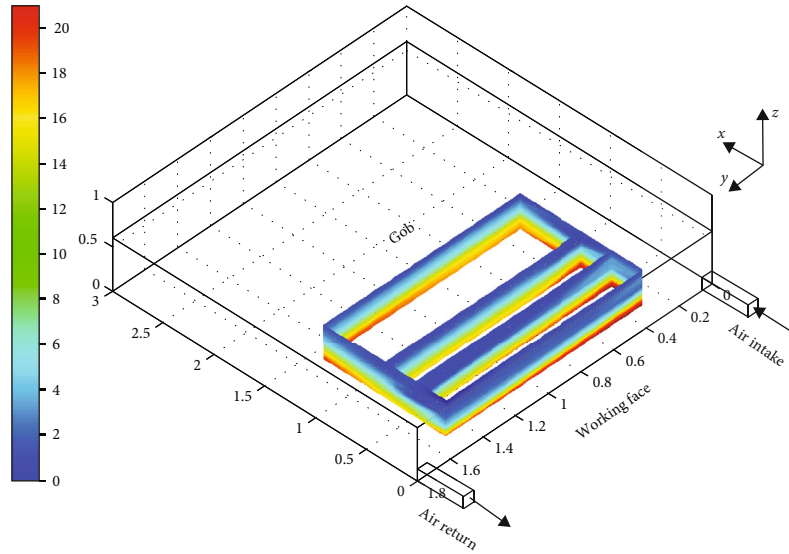

FIGURE 5: O_2 concentrations at $x = 0.2, 0.5, 0.8,$ and 1.4 m and $y = 0.3$ and 1.5 m with N_2 injection rate of 3.4 L/min, 0° .

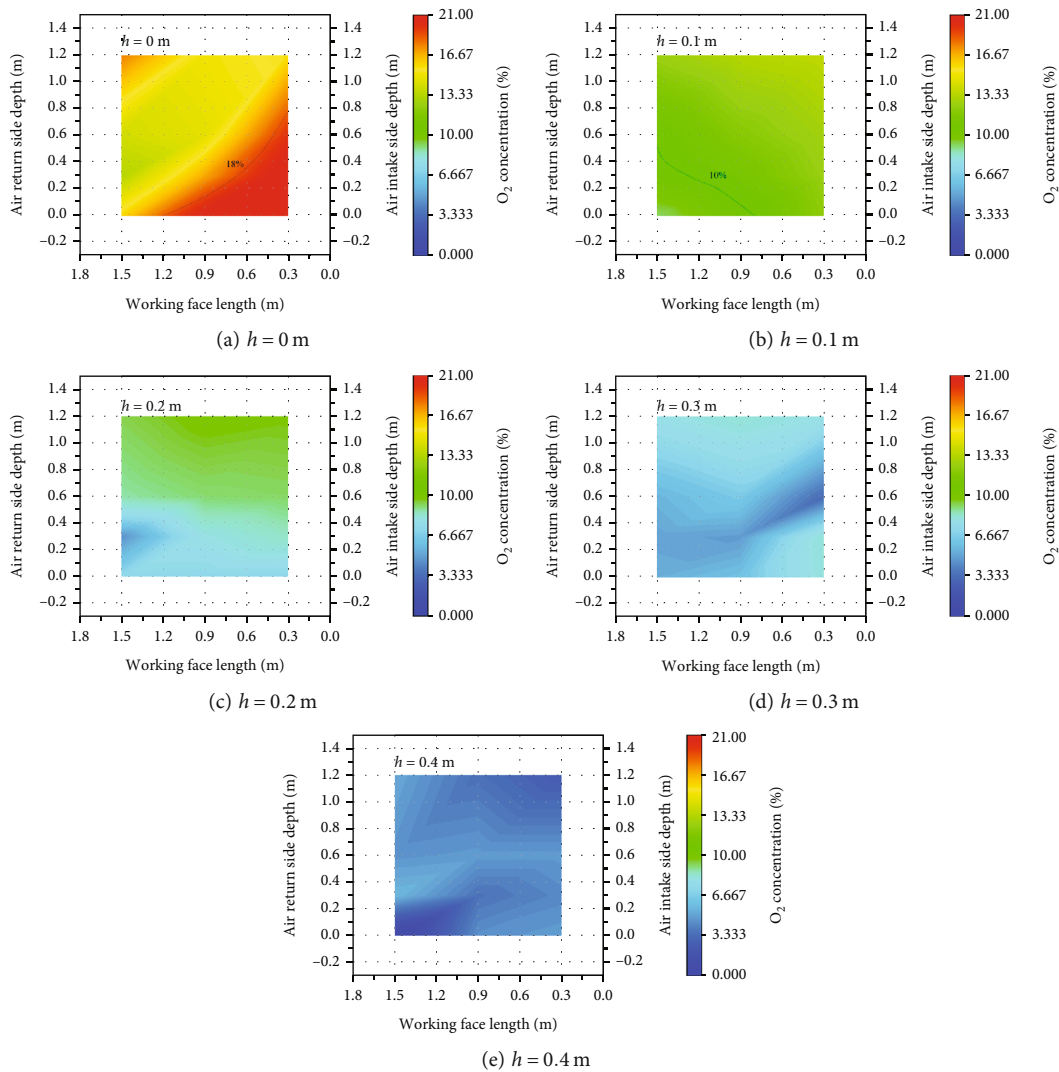

FIGURE 6: Cloud distribution of O_2 concentration at different heights with the N_2 injection rate of 3.4 L/min, 0° .

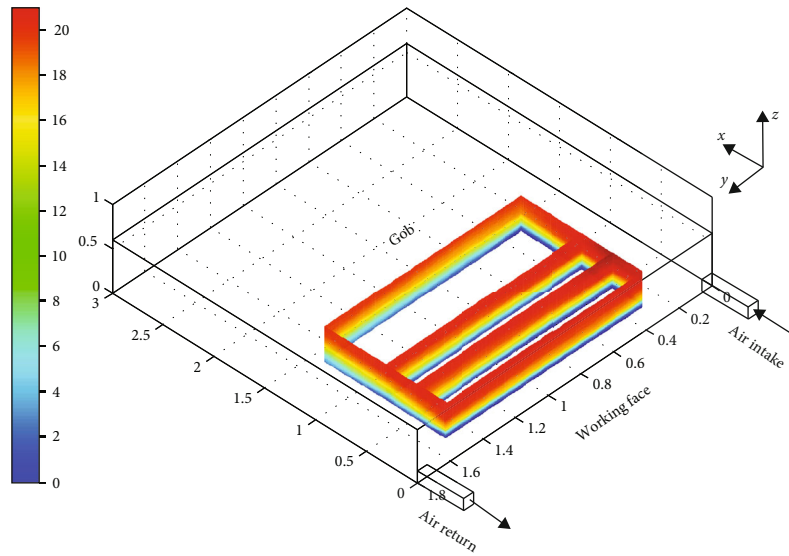

FIGURE 7: O_2 concentrations at $x = 0.2, 0.5, 0.8,$ and 1.4 m and $y = 0.3$ and 1.5 m with CO_2 injection rate of 3.4 L/min, 0° .

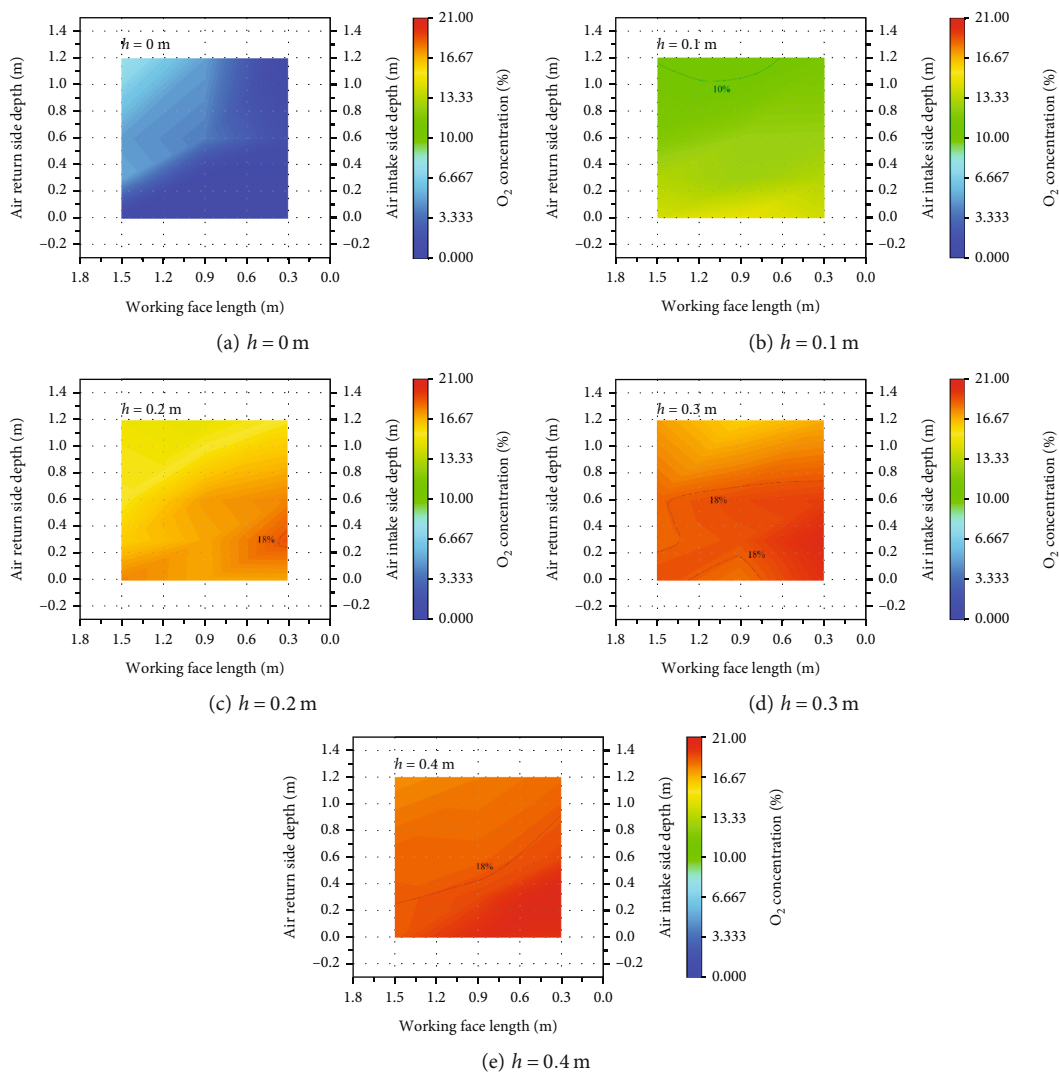

FIGURE 8: Cloud distribution of O_2 concentration at different heights with the CO_2 injection rate of 3.4 L/min, 0° .

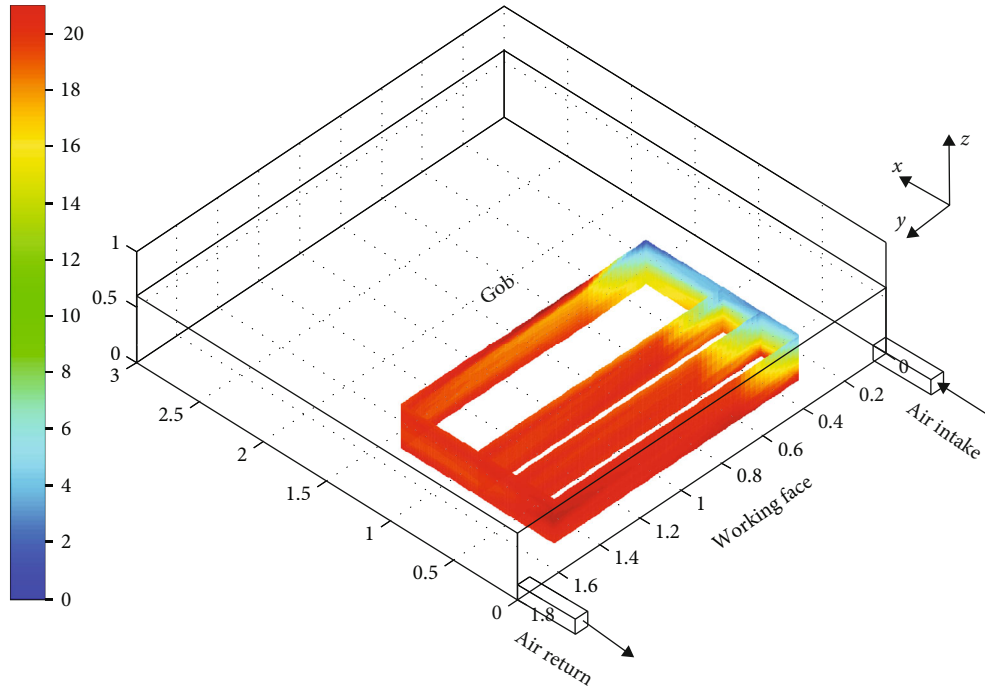

FIGURE 9: O_2 concentrations at $x = 0.2, 0.5, 0.8,$ and 1.4 m and $y = 0.3$ and 1.5 m with N_2 injection rate of 1.1 L/min, 45° .

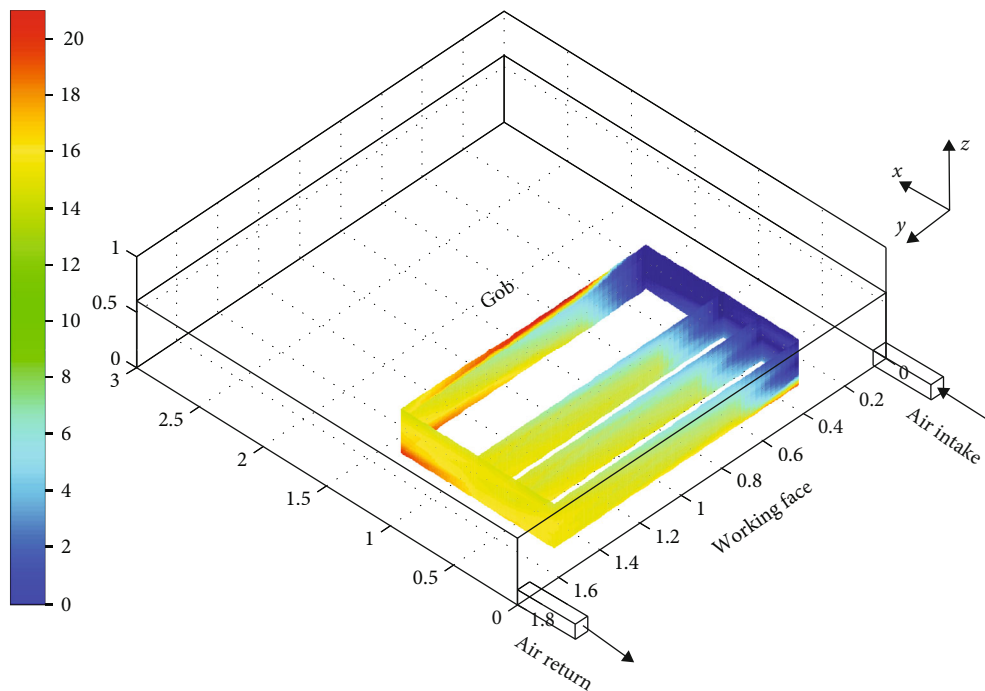

FIGURE 10: O_2 concentrations at $x = 0.2, 0.5, 0.8,$ and 1.4 m and $y = 0.3$ and 1.5 m with N_2 injection rate of 2.3 L/min, 45° .

simulation model is the same as that in the real goaf. The volume proportion of inert gas to air injected in the model is also the same as in the real goaf

- (iii) *Dynamic similarity*: the force of the airflow in the similarity simulation experiment platform of large inclined goaf is the same as that in the real goaf,

and force direction is also the same if secondary factors are not considered [18]

2.2.2. Platform Construction. The experimental platform simulated the O_2 distribution and inert gas migration law under different flow rates after injecting N_2 and CO_2 into

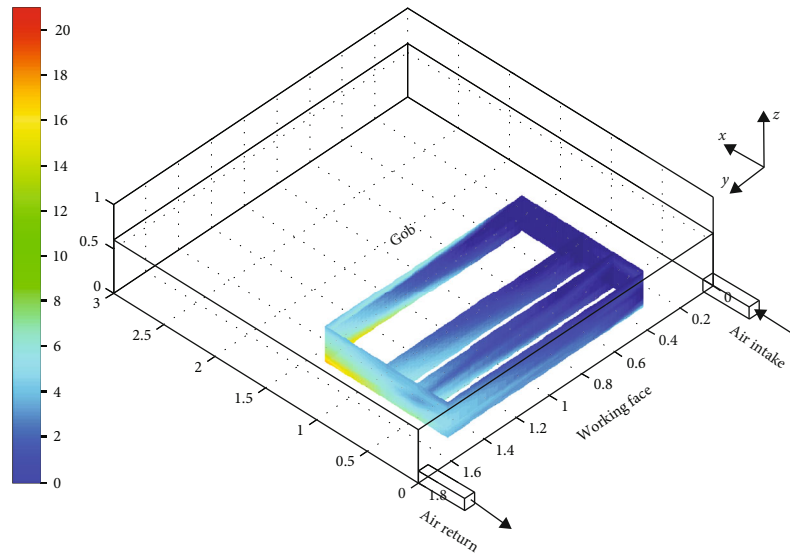

FIGURE 11: O_2 concentrations at $x = 0.2, 0.5, 0.8,$ and 1.4 m and $y = 0.3$ and 1.5 m with N_2 injection rate of 3.4 L/min, 45° .

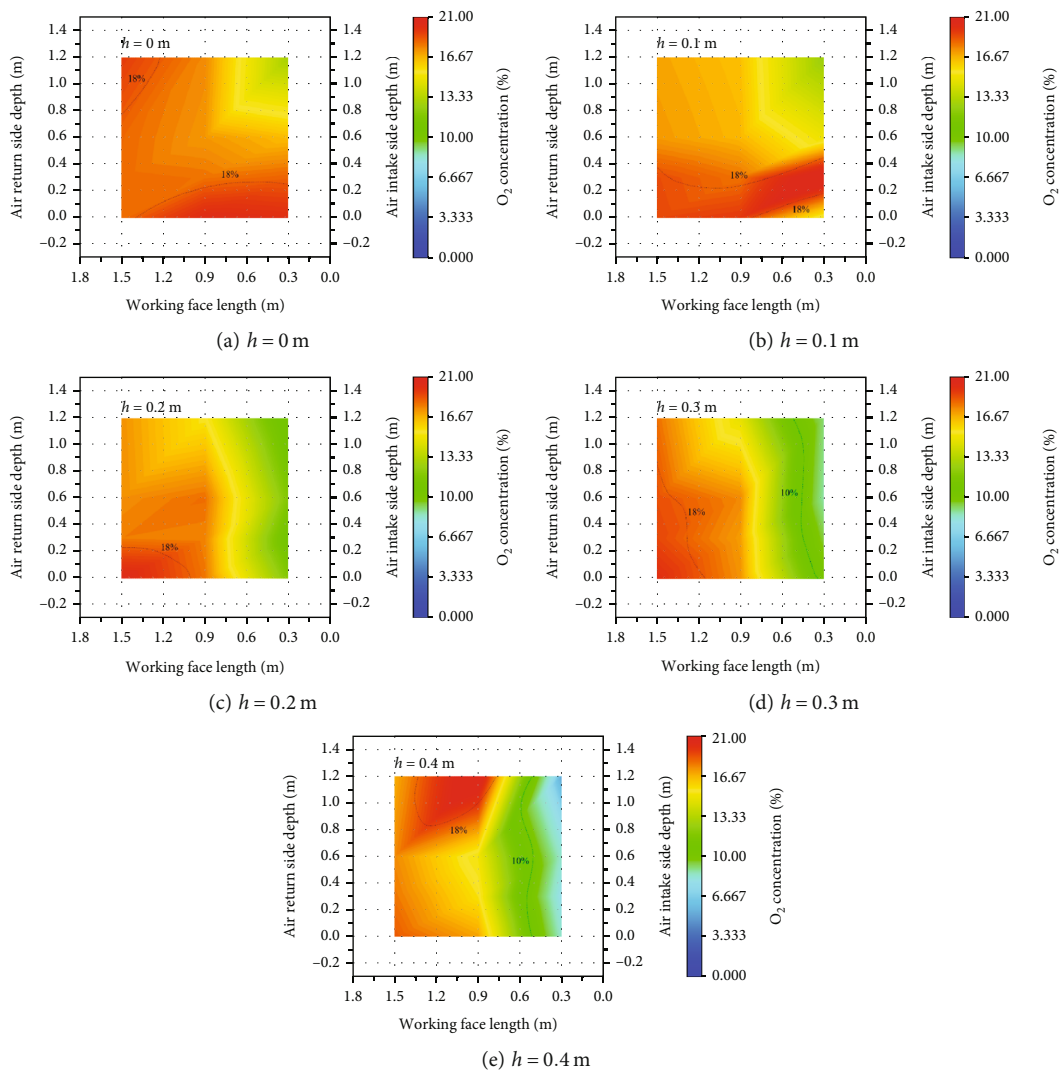

FIGURE 12: Cloud distribution of O_2 concentration at different heights with the N_2 injection rate of 1.1 L/min, 45° .

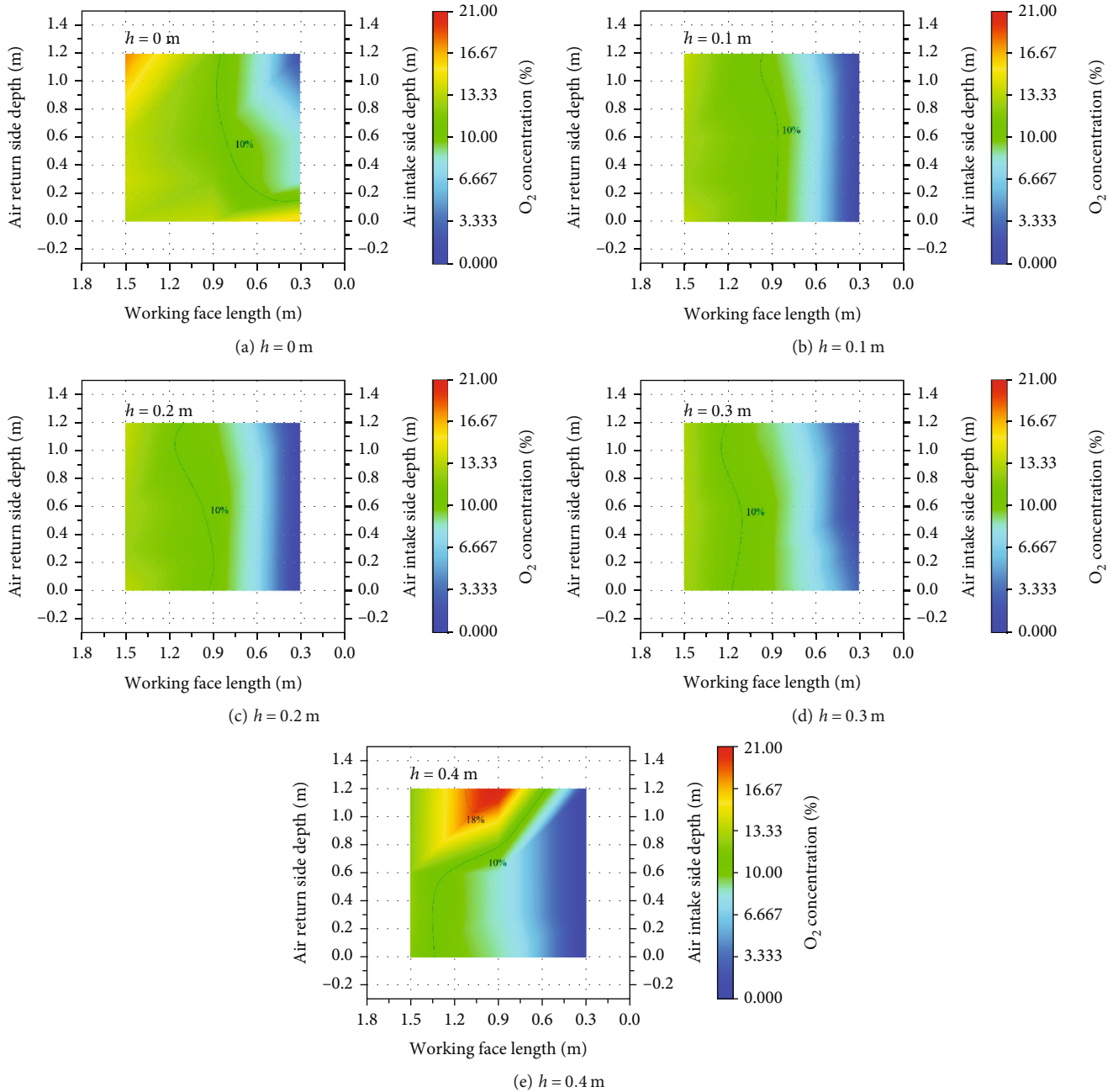

FIGURE 13: Cloud distribution of O_2 concentration at different heights with the N_2 injection rate of 2.3 L/min, 45° .

the large inclined goafs. The experimental platform includes the box, ventilation, data collection, and inert gas injection systems. The schematic diagram of the experimental platform is shown in Figure 1.

(1) *The Box System.* The box simulating a large inclined goaf is the main part of the experimental platform. It includes the box body and two long roadways. The box is made of a 50 mm angle steel frame and a 2 mm thick stainless steel bottom plate welded to the frame. The dimension of the main box is $3\text{ m} \times 2\text{ m} \times 1\text{ m}$. The goaf and roadway are constructed with transparent PMMA

acrylic plate to simulate the supporting coal wall. Two rotating supports are welded between the bottom plate and the frame. By synchronously rotating the two nuts, the whole platform can be tilted to the left in the range of 0° to 55° .

According to the coal and rock distribution law in large inclined goaf, the coal caving and the distribution of the remaining coal are very irregular. Thus, organic foams of different diameters are used to fill up the box and approximate the spatial characteristics of the porous medium in large inclined goafs. A layer of broken coal blocks is laid

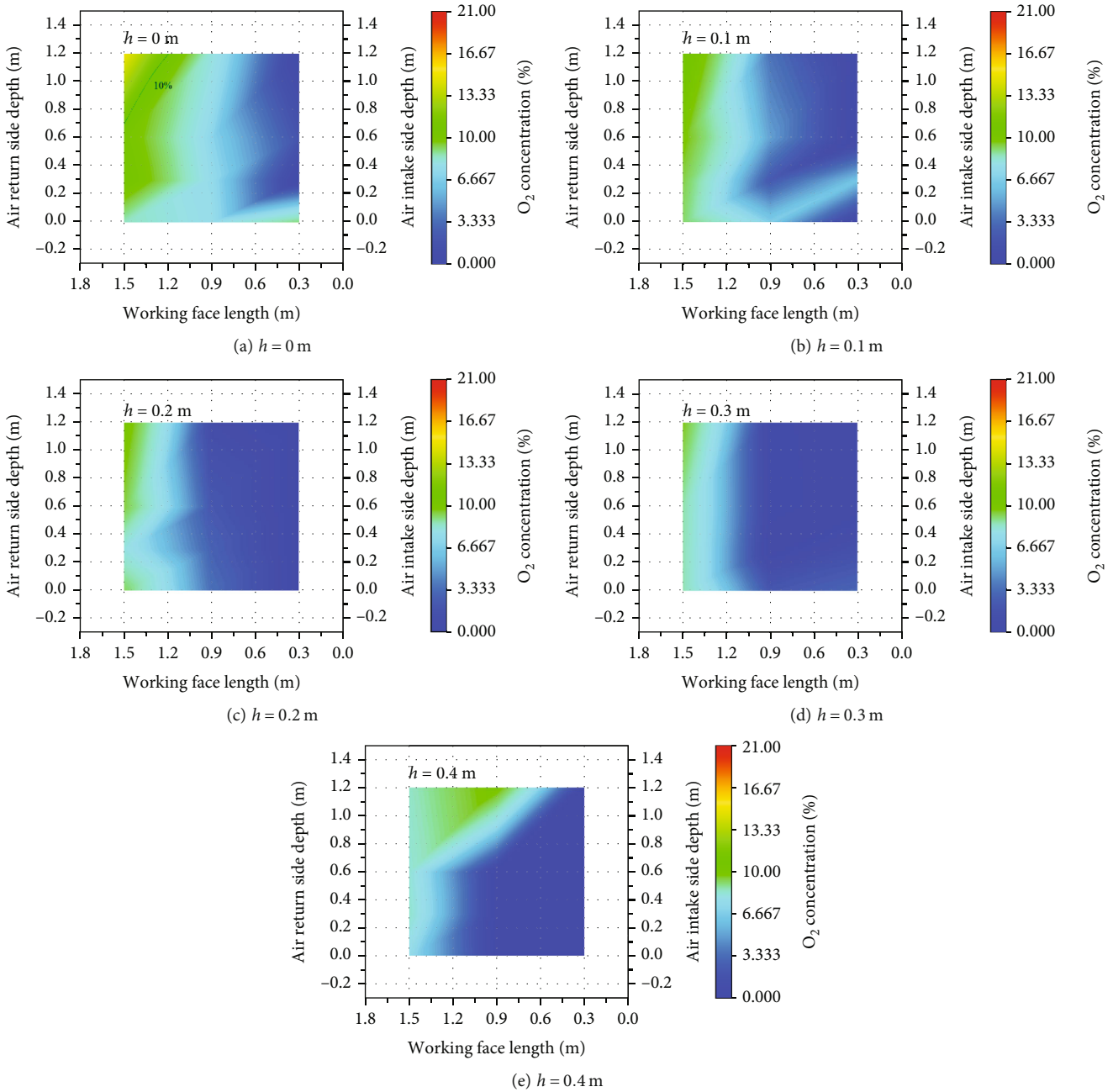

FIGURE 14: Cloud distribution of O_2 concentration at different heights with the N_2 injection rate of 3.4 L/min, 45°.

on the bottom of the box to simulate the residual coal in the goaf.

(2) *The Ventilation System.* The ventilation system is designed to adjust the ventilation parameters of the similarity simulation experiments. It includes a negative pressure vacuum pump and a rotameter. The vacuum pump is connected to the left air return roadway to simulate the extraction downward ventilation mode of the working face. The rotameter is used to measure and help control the air volume of the working face, as shown in Figure 2.

(3) *The Data Collection System.* The data collection system records the monitoring data in real time. Figure 3 shows a detailed layout of the oxygen measurement points. A total of 60 oxygen sensors were arranged in the goaf box to measure the spatial distribution of O_2 in the goaf and indirectly reflect the migration law of N_2/CO_2 in the goaf.

(4) *The Inert Gas Injection System.* The inert gas injection system simulates the inert gas injection into the goaf. The system includes the N_2 or CO_2 gas cylinders, gas pressure reducing valves, gas buffer tanks, air rotor flow meters, and

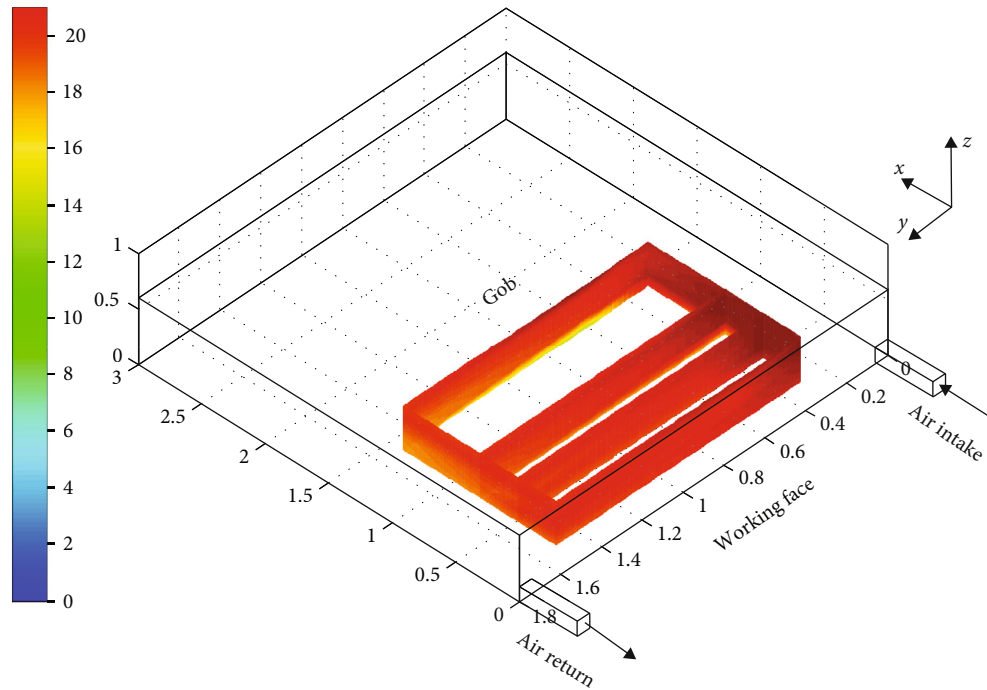

FIGURE 15: O_2 concentrations at $x = 0.2, 0.5, 0.8,$ and 1.4 m and $y = 0.3$ and 1.5 m with the CO_2 injection rate of 1.1 L/min, 45° .

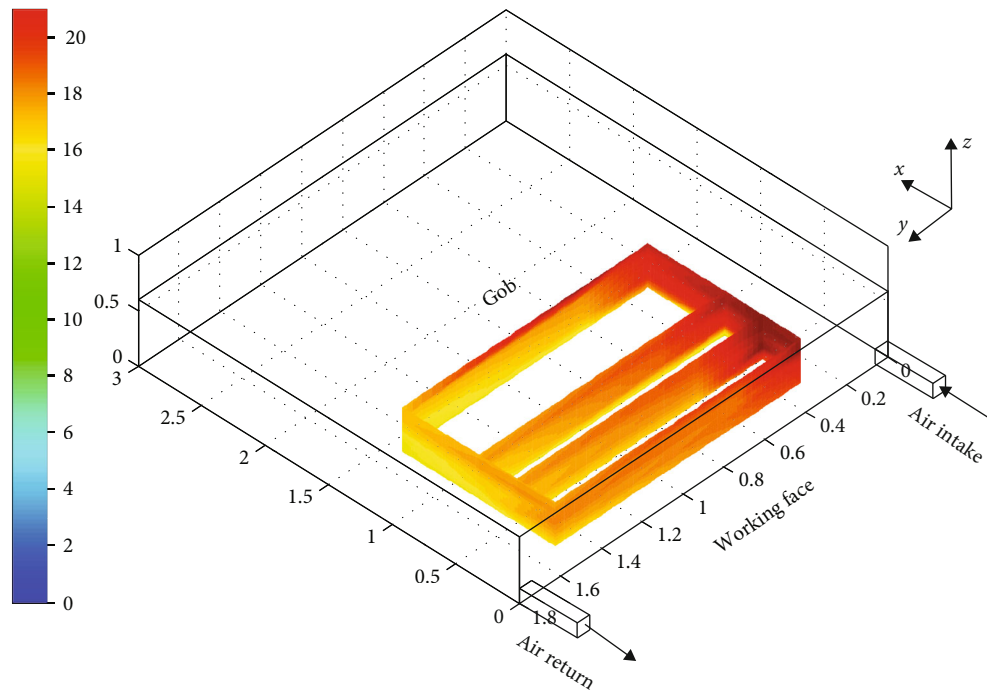

FIGURE 16: O_2 concentrations at $x = 0.2, 0.5, 0.8,$ and 1.4 m and $y = 0.3$ and 1.5 m with the CO_2 injection rate of 2.3 L/min, 45° .

transparent PU pipes with a diameter of 14 mm, as shown in Figure 4. The N_2 or CO_2 cylinders simulate the source of inert gas injected into the goaf. The two cylinders are connected with a three-way joint to ensure a sufficient inert gas source during the experiment. The gas pressure-reducing valve is connected to the gas cylinder to maintain an absolute pressure so that the outflow of inert gas is

smooth and continuous. Gas buffer tanks are used to buffer the airflow and a certain amount of inert gas and ensure the continuity of inert gas injection during the experiment.

2.3. Experimental Methods. The purpose of this experiment is to qualitatively analyze the inert gas migration law in the large inclination goaf under different flow

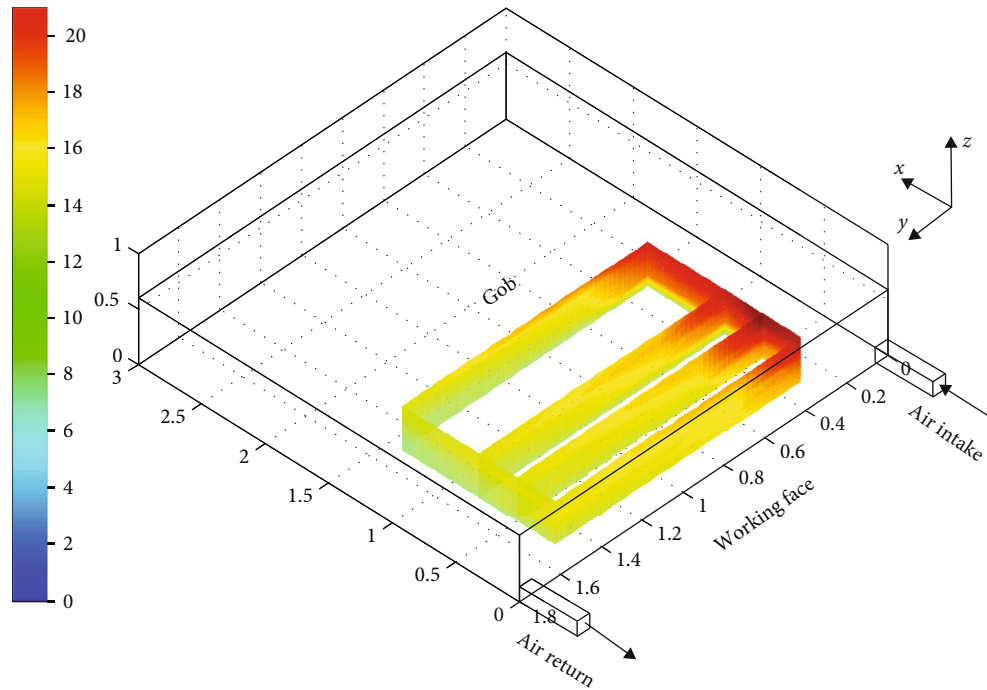

FIGURE 17: O_2 concentrations at $x = 0.2, 0.5, 0.8,$ and 1.4 m and $y = 0.3$ and 1.5 m with the CO_2 injection rate of 3.4 L/min, 45° .

conditions and the change law of the three spontaneous combustion zones in the goaf. Since the experiment indirectly analyzes the migration process of N_2 or CO_2 by monitoring the spatial distribution of O_2 , and the central area of N_2 or CO_2 inerting is the oxidation zone, it is assumed that the gas composition in the goaf is all air at the beginning of the experiment. The experiment includes two parts:

- (1) A simulation experiment with similar migration law of N_2 in the goaf
- (2) A simulation experiment with similar migration law of CO_2 in the goaf

The actual ventilation rate of working face 37121-1 in the Dongxia coal mine is 880 m³/min. According to the similarity criteria, the ventilation rate of the working face in the experiment is set to 5.0 L/min, and the flow rate of N_2 or CO_2 is set to 1.1 L/min, 2.3 L/min, and 3.4 L/min, corresponding to the actual N_2 or CO_2 injection flow rates of 200 m³/min, 400 m³/min, and 600 m³/min. The depth of the N_2 or CO_2 injection pipeline in the experiment is 0.67 m, corresponding to the actual depth of 40 m. Since the maximum inclination angle of working face 37121-1 is 45° , the rotation angle of the platform is set to 45° in the experiment. Table 2 shows the experimental scheme. The ventilation mode of the simulated working face is downward ventilation, and the position of N_2 or CO_2 injection is located in the high-level air intake side.

Before the experiment, the inclination angle of the experiment platform was set to 45° , and the negative pressure vac-

uum pump was connected to the air return side. At the same time, the gas injection pipeline was connected to the N_2/CO_2 perfusion system. The vacuum pump was turned on to pressurize the similarity model for at least 3 h to fill it with air and adjust the readings of the 60 oxygen sensors to 20.95%. After that, the ventilation system was turned on, and the negative pressure and the exhaust airflow were adjusted. The air rotor flowmeter read 5.0 L/min, indicating continuous and stable ventilation. Therefore, the typical ventilation environment of the working face was simulated. The N_2/CO_2 cylinder valve was opened, and the flow rate of N_2/CO_2 was adjusted through the rotameter to continuously and stably pass N_2/CO_2 into the similarity model. The data collection system recorded the data in real time. When the concentration was stable, the readings of each O_2 sensor were saved, and the experiment concluded.

3. Results and Discussions

3.1. Inclination Angle of 0° . To verify the feasibility of studying the dangerous area in the goaf and the inert gas migration law with a similarity model, we conducted N_2 and CO_2 injection experiments at the 0° inclination angle with a flow rate of 3.4 L/min. The oxygen concentration distribution in the six sections at $x = 0.2, x = 0.5, x = 0.8, x = 1.4, y = 0.3,$ and $y = 1.5$ m and the cloud distribution of O_2 concentration at $h = 0, h = 0.1, h = 0.2, h = 0.3,$ and $h = 0.4$ m are shown in the following figures.

As shown in Figures 5 and 6, the N_2 injection exerts inerting effects on the upper side of the goaf but no significant inerting effect on the lower side. The inerting effect of N_2 improves with the increase of the distance from the floor. The N_2 injection can reduce the oxygen concentration to

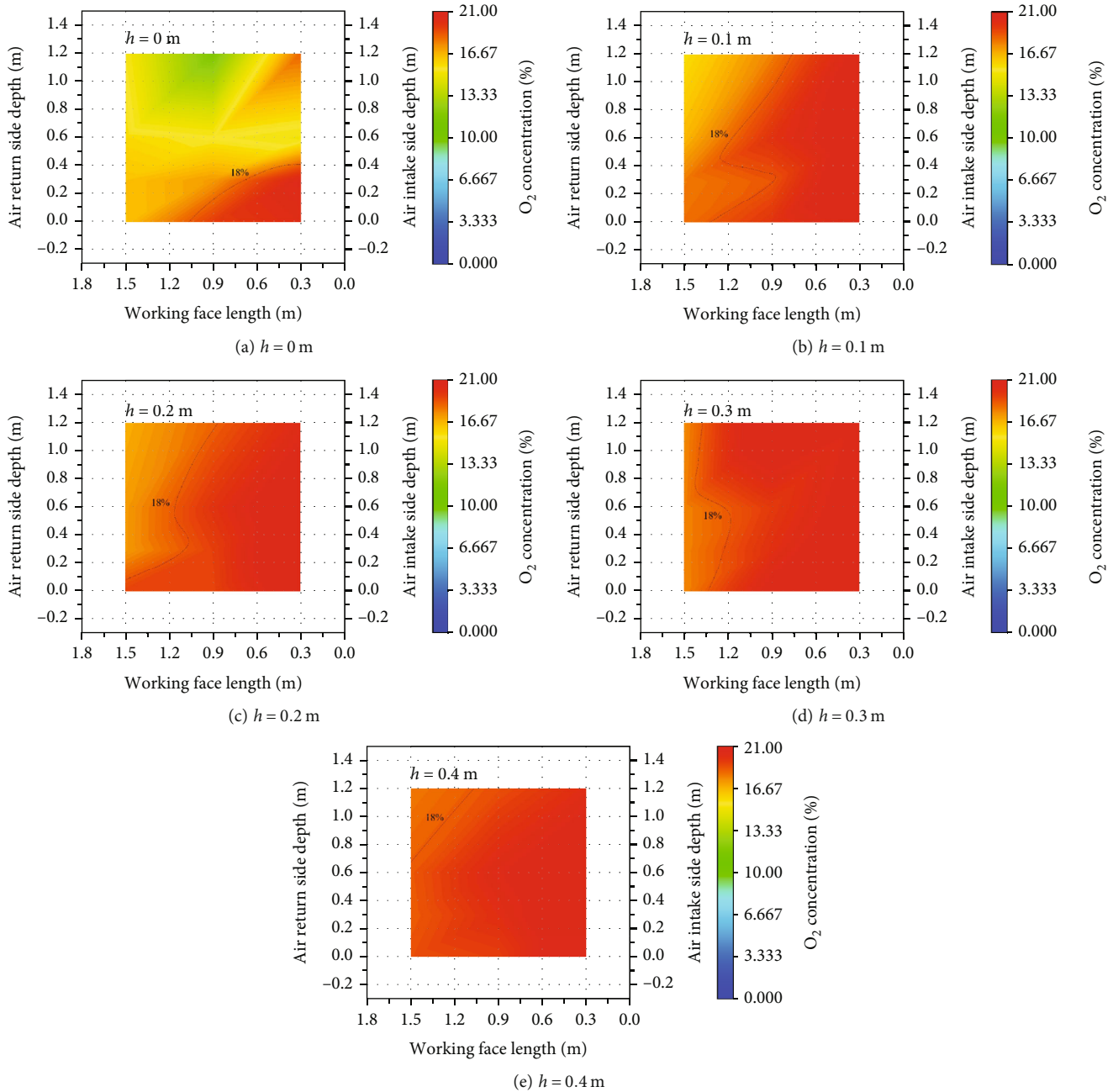

FIGURE 18: Cloud distribution of O_2 concentration at different heights with the CO_2 injection rate of 1.1 L/min, 45° .

below 10% at $h = 0.2$ m, 0.3 m, and 0.4 m and keep the coal entirely within the range of the suffocation zone. As shown in Figures 7 and 8, the CO_2 injection exerts apparent inerting effects on the lower side of the goaf but has poor inerting effects on the upper side. CO_2 only keeps the coal within the range of suffocation zone at $h = 0$ m, while the oxygen concentration at other heights is high, indicating that the CO_2 migration is much worse than that of N_2 .

3.2. Inclination Angle of 45°

3.2.1. N_2 Injection. When the N_2 injection rate is 1.1, 2.3, and 3.4 L/min, the oxygen concentration distributions at $x = 0.2$,

0.5, 0.8, and 1.4 m and $y = 0.3$ and 1.5 m are shown in Figures 9–11, respectively.

The deeper blue color in the high area indicates low oxygen concentration. With the increase of the injection rate, N_2 diffuses to a larger area. When the N_2 flow rate is 1.1 L/min, the areas on the upper side of the goaf have a low N_2 inerting effect, but most areas have no inerting effect and high oxygen concentration. When the N_2 injection rate increases to 2.3 L/min, the N_2 inerting range is larger with decreased oxygen concentration on the lower side of the goaf. When the N_2 injection rate increases to 3.4 L/min, the N_2 inerting effect on the lower side of the goaf is more significant, and the color of other areas is dark blue, indicating decreased

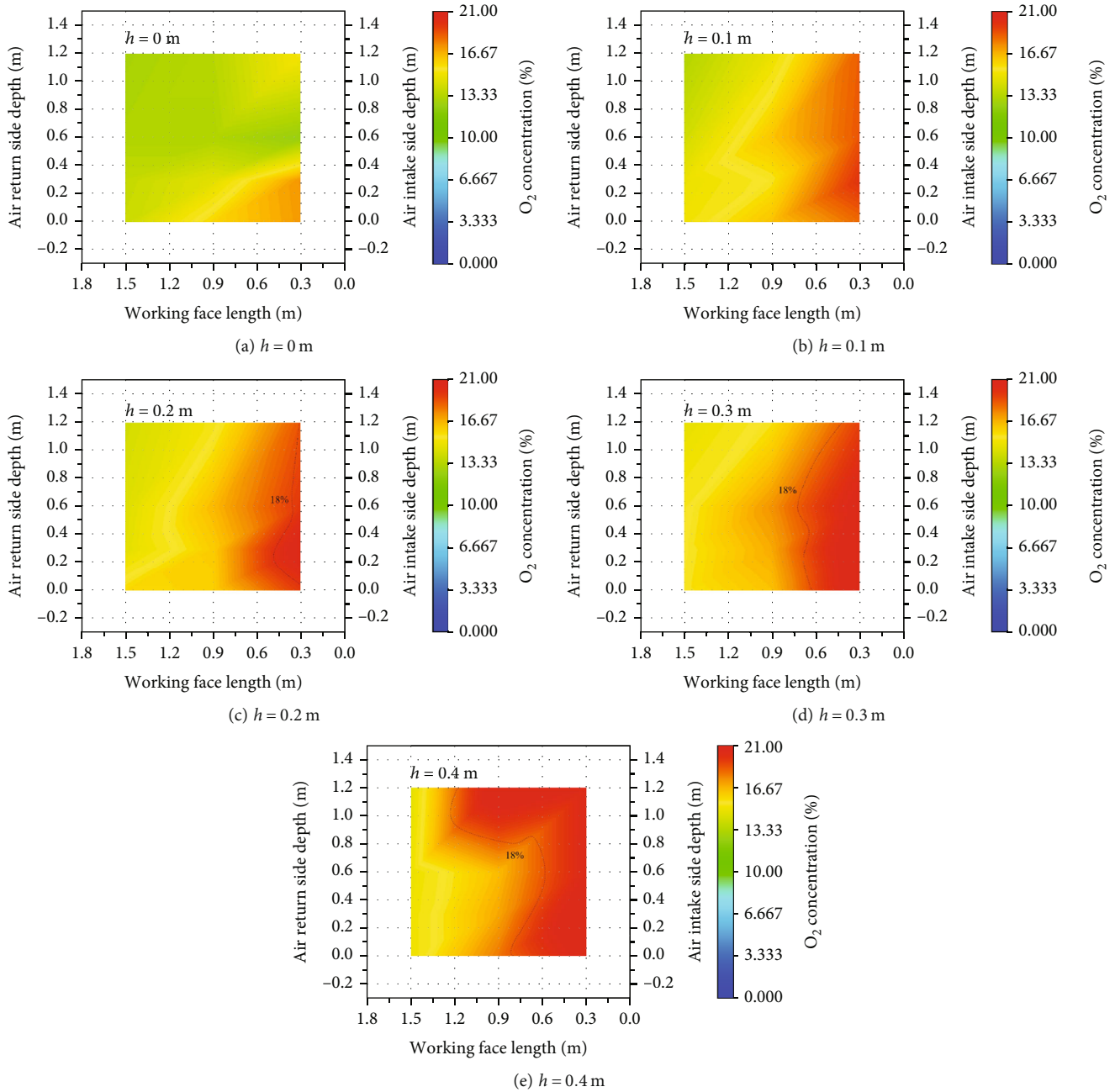

FIGURE 19: Cloud distribution of O₂ concentration at different heights with the CO₂ injection rate of 2.3 L/min, 45°.

oxygen concentration with the increased N₂ injection rate. Thus, a higher N₂ injection rate has a better inerting effect on the large inclined goaf.

As shown in Figures 12–14, the oxygen concentration distribution at different heights of the goaf is basically the same under different N₂ injection rates, and N₂ is mainly distributed at the air inlet side of the goaf. When the N₂ injection rate is 1.1 L/min, the oxygen concentration near the goaf floor is above 10% ($h = 0.1$ m and $h = 0.2$ m), and the oxidation zone of the goaf is large ($10\% < c_{O_2} < 18\%$). At 0.3 m and 0.4 m from the floor, the suffocation zone appears. When the N₂ injection rate is 2.3 L/min, the oxida-

tion zone decreases with the distance from the bottom plate. As the N₂ injection rate increases to 3.4 L/min, the whole goaf is basically within the range of the suffocation zone, and the residual coal in the goaf is not prone to spontaneous combustion.

3.2.2. CO₂ Injection. As shown in Figures 15–17, the inerting area of CO₂ is utterly different from that of N₂. The inerting area is mainly reflected by CO₂ injection. The CO₂ reaches the side of the low-level air return side at first and gradually diffuses from the low-level air return side to the high-level air intake side with the increase of the

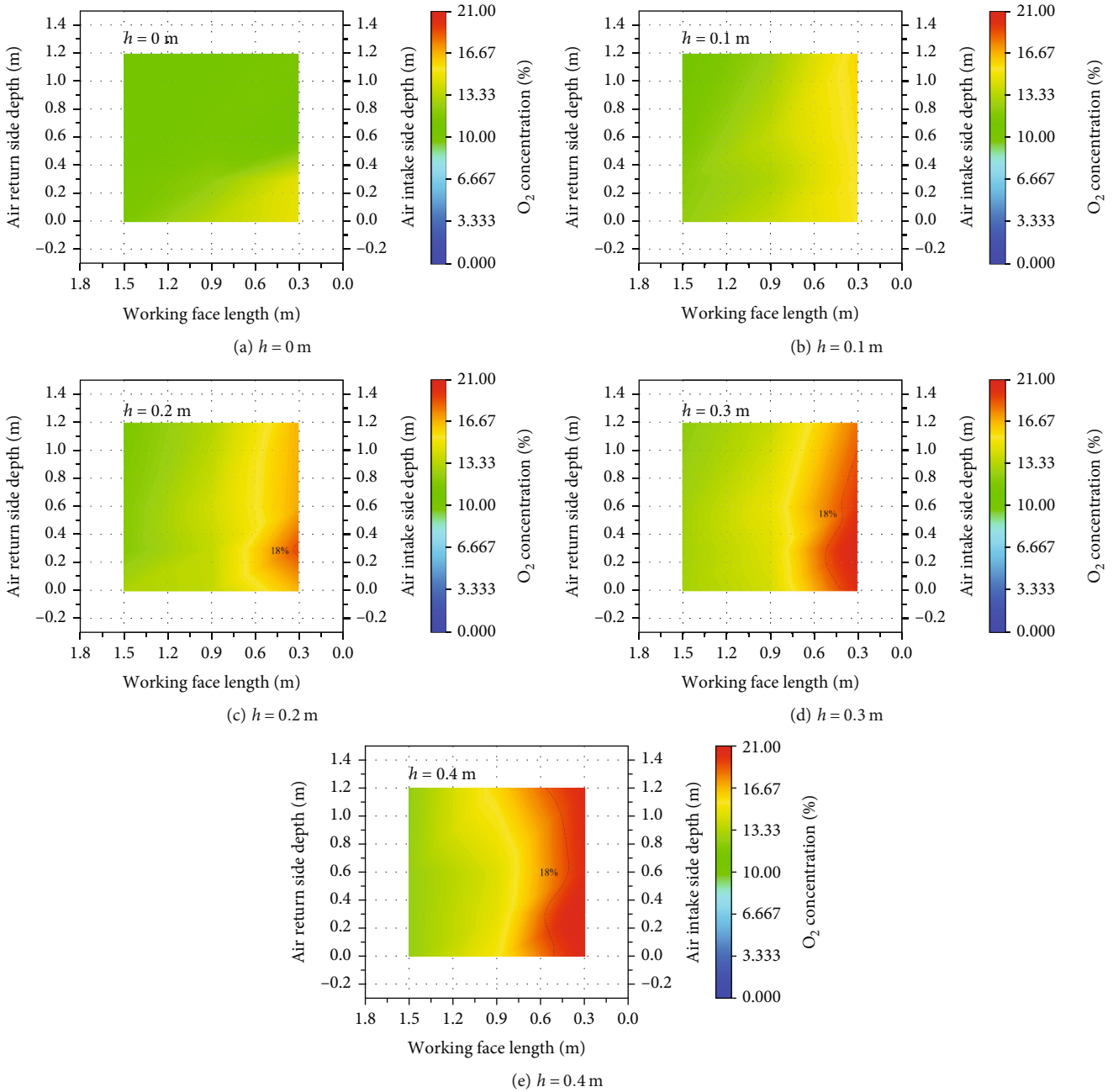

FIGURE 20: Cloud distribution of O_2 concentration at different heights with the CO_2 injection rate of 3.4 L/min, 45° .

CO_2 injection rate. When the CO_2 injection flow is 1.1 L/min, the inerting area is mainly located on the lower side of the goaf. The range of blue area is very limited, indicating that the injection flow is not enough to keep the goaf inert. As the CO_2 injection rate increases to 2.3 L/min, the CO_2 inerting area becomes larger, and the oxygen concentration on the lower side of the goaf decreases significantly. When the CO_2 injection rate increases to 3.4 L/min, the oxygen concentration on the lower side of the goaf decreases further, but that in the goaf cannot be reduced to a lower level.

As shown in Figures 18–20, the oxygen concentration distribution law is basically the same at different heights of the goaf under different CO_2 injection rates. CO_2 is mainly distributed on the return side of the goaf. When the CO_2 injection rate is 1.1 L/min, the oxygen concentration at each height from the goaf floor is above 10%. The oxygen concentration increases with the distance from the goaf floor, and the 18% oxygen concentration line at $h = 0.1, 0.2,$ and 0.3 m presents an S-type distribution. Even with the CO_2 injection rate increasing to 2.3 and 3.4 L/min, the oxygen concentration in the goaf is still high above 10%. Most of

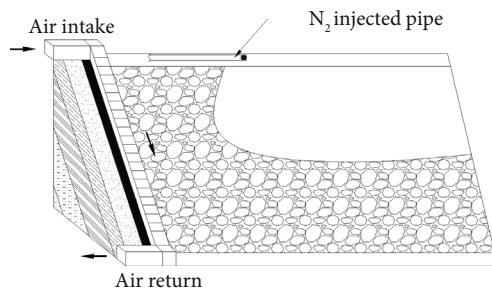

FIGURE 21: Schematic diagram of N_2 migration in large dip goaf.

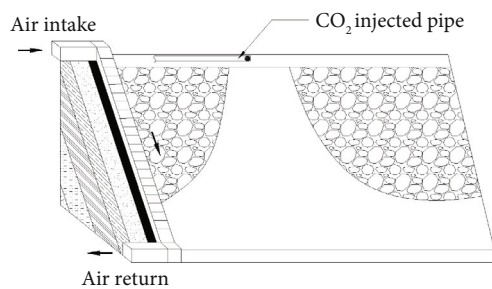

FIGURE 22: Schematic diagram of CO_2 migration in large dip goaf.

the goaf is in the oxidation zone, and the residual coal is prone to spontaneous combustion.

3.3. The N_2 and CO_2 Injection Migration Mechanisms and Laws

3.3.1. The N_2 and CO_2 Injection Migration Mechanisms. When injected into goafs with large inclinations, N_2 accumulates in the upper space of the air intake side due to gravity and then spreads downward and toward the air return side. The N_2 injection flow is crucial to the spontaneous combustion zone distribution in the goaf. With increased N_2 injection, the range and width of the oxidation zone decreased, and the end of the loose zone and oxidation zone moved forward to the working face, where the end of the oxidation zone moved further than that of the loose zone.

When injected into goafs with large inclinations, CO_2 diffuses along the goaf bottom to the side of the low-level air return side due to gravity and then slowly diffuses upward. The inerting effect of CO_2 on the floor area of goafs with large inclinations was less significant than that of horizontal goafs because CO_2 was denser than air. With large inclinations, CO_2 flows along the air intake side to the low-level air return side of the goaf. Part of CO_2 dissipates along with the airflow of the working face, which reduces CO_2 accumulation in the air return side, resulting in poor inerting effects.

3.3.2. The N_2 and CO_2 Injection Migration Laws. The N_2 and CO_2 inerting effects and migration laws in the goaf area with large inclinations are shown in Figures 21 and 22, respectively. When N_2 is injected into the goaf area with large inclinations, N_2 accumulates in the upper area of the lower part of the inlet side since N_2 is lighter than air and gradually dif-

fuses toward the low-level high oxygen area. The migration profile of N_2 approximates an L shape. When injected, CO_2 accumulates to the low-level air return side and gradually diffuses toward the high oxygen area in the deep part of the high-level air intake side since CO_2 is denser than air. There is also a high oxygen area near the working face due to ventilation. The migration profile of CO_2 resembles a trumpet shape, in which the bell mouthing is located in the CO_2 filling port of the air intake side.

4. Conclusion

In this paper, the inerting effects and migration laws of N_2 and CO_2 injections into the goaf with large inclinations were studied with a similarity simulation model. The results showed that with the increase of N_2 and CO_2 injection, the range and width of the oxidation zone decreased, and the end of the loose zone and the oxidation zone moved forward to the working face. When injected at the same flow rate, CO_2 flew to the air return side and dissipated with the airflow of the working face due to its higher density than air, and the inerting effects were far less significant than that of N_2 . The migration profile of N_2 in the goaf approximated an L shape, and that of CO_2 approximated a trumpet shape. Therefore, the inerting effects of N_2 were superior in terms of fire prevention and extinguishment in large inclined goafs.

Data Availability

The data used to support the findings of this study are included within the article.

Additional Points

Coal Mining Terminology. Working face: the first production site of coal, with narrow working space, mechanical equipment, poor visual environment, high temperature characteristics. Goaf: the cavity or cavity left after the underground coal or coal gangue is mined in the process of coal mining. Air intake: the fresh air flow for the working face. Air return: the turbid wind after fresh air passing through the working face and goaf.

Conflicts of Interest

The authors declare that they have no conflicts of interest.

Acknowledgments

This work was supported by the National Natural Science Foundation of China (Grant No. 52074277) and Natural Science Foundation of Jiangsu Province (Grant No. BK20211585).

References

- [1] M. Liu, "Research on fully mechanized mining technology of large inclined working face," *Shanxi Metallurgy*, vol. 42, no. 5, pp. 117-118, 2019.

- [2] L. Ma, X. Song, H. Wen, and X. Meng, "Research on fire prevention and control technology for seam spontaneous combustion in overlong fully mechanized longwall coal mining face," *Coal Engineering*, vol. 3, pp. 58–60, 2006.
- [3] S. Shao, C. Wu, M. Hao et al., "A novel coating technology for fast sealing of air leakage in underground coal mines," *International Journal of Mining Science and Technology*, vol. 31, no. 2, pp. 313–320, 2021.
- [4] B. Hao, X. Lv, and J. Wang, "Mining's choice in inclined thick seam," *Coal Technology*, vol. 27, no. 2, pp. 43–45, 2008.
- [5] L. Tao and Y. Wang, "Overlying strata movement and failure in steeply dipping coal seam," *Journal of China Coal Society*, vol. 6, pp. 23–26, 1996.
- [6] L. Ge, Y. Shao, Y. Wang, G. Zhang, Z. Zhang, and L. Liu, "Experimental research on inerting characteristics of carbon dioxide used for fire extinguishment in a large sealed space," *Process Safety and Environmental Protection*, vol. 142, pp. 174–190, 2020.
- [7] Q. Chen and X. Wang, "Research on the law of spontaneous combustion of coal and nitrogen injection fire-fighting technology in fully mechanized caving face," *Journal of China Coal Society*, vol. 6, pp. 618–623, 1996.
- [8] Y. Zhuang, G. Zhao, Q. Bao et al., "Isolated nitrogen injection fire prevention and extinguishing technology in layered mining of thick coal seam," *Coal Science & Technology*, vol. 11, pp. 31–34, 1998.
- [9] N. Zheng, "Discussion on nitrogen injection fire prevention and extinguishing technology in fully mechanized mining face under complex geological conditions," *Coal Technology*, vol. 12, pp. 49–50, 2003.
- [10] Z. Cao, J. Shi, H. Zhang, X. Chun, and K. Zhao, "Study on influence of nitrogen injection flow rate on nitrogen diffusion radius in goaf," *Mining Safety and Environmental Protection*, vol. 46, no. 5, pp. 12–15, 2019.
- [11] J. Cao, J. Wu, C. Zhou, and Y. Tang, "Division of spontaneous combustion dangerous region and determination of nitrogen injection position in goaf of low level top coal caving mining face," *Coal Science & Technology*, vol. 45, no. 2, pp. 89–94, 2017.
- [12] H. Shao, S. Jiang, Z. Wu, W. Zhang, and K. Wang, "Numerical simulation on fire prevention by infusing carbon dioxide into goaf," *Journal of Mining and Safety Engineering*, vol. 30, no. 1, pp. 154–158, 2013.
- [13] H. Shao, S. Jiang, Z. Wu, W. Zhang, and K. Wang, "Comparative research on the influence of dioxide carbon and nitrogen on performance of coal spontaneous combustion," *Journal of China Coal Society*, vol. 39, no. 11, pp. 2244–2249, 2014.
- [14] G. Wang, J. Deng, X. Zhang, Y. Xiao, and J. Sun, "Determination of parameters of injecting CO₂ to prevent spontaneous combustion in gob of fully mechanized top-coal caving," *Journal of Liaoning Technical University (Natural Science)*, vol. 28, no. 2, pp. 169–172, 2009.
- [15] H. Su, F. Zhou, X. Song, B. Shi, and S. Sun, "Risk analysis of coal self-ignition in longwall gob: a modeling study on three-dimensional hazard zones," *Fire Safety Journal*, vol. 83, pp. 54–65, 2016.
- [16] H. Su, F. Zhou, X. Song, and Z. Qiang, "Risk analysis of spontaneous coal combustion in steeply inclined longwall gobs using a scaled-down experimental set-up," *Process Safety and Environmental Protection*, vol. 111, pp. 1–12, 2017.
- [17] M. Hao, Y. Li, X. Song, J. Kang, H. Su, and F. Zhou, "Hazardous areas determination of coal spontaneous combustion in shallow-buried gobs of coal seam group: a physical simulation experimental study," *Environment and Earth Science*, vol. 78, no. 1, pp. 31–39, 2019.
- [18] M. Hao, Y. Li, X. Song, J. Kang, H. Su, and F. Zhou, *Hazardous Areas Distribution of Coal Spontaneous Combustion in Shallow-Buried Compound Gobs of Coal Seam Group*, vol. 78, no. 1, 2019, China University of mining and technology, Xuzhou, 2019.