

Research Article

Comparative Analysis of Reliable, Feasible, and Low-Cost Photovoltaic Microgrid for a Residential Load in Rwanda

Cyprien Nsengimana , Xin Tong Han , and Ling-ling Li 

State Key Laboratory of Reliability and Intelligence of Electrical Equipment, School of Electrical Engineering, Hebei University of Technology, Tianjin 300130, China

Correspondence should be addressed to Cyprien Nsengimana; cyprienn98@gmail.com

Received 9 September 2020; Revised 23 October 2020; Accepted 30 October 2020; Published 21 November 2020

Academic Editor: Kumarasamy Sudhakar

Copyright © 2020 Cyprien Nsengimana et al. This is an open access article distributed under the Creative Commons Attribution License, which permits unrestricted use, distribution, and reproduction in any medium, provided the original work is properly cited.

Photovoltaic microgrids provide free renewable energy solutions for Rwandans. Although solar technology keeps on its advancement, hydropower remains the principal power source in Rwanda. Other renewable power sources include wind and geothermal energies that are not yet fully exploited. Nonrenewable sources in Rwanda including methane, peat, thermal, and fuels are also used for providing energy solutions for the citizens. Rwanda Energy Group (REG) sets the energy strategic plan since 2015 for achieving the minimum of 512 MW of energy production in 2024/2025 to meet the total energy demand. The plan predicted 52% for grid-connected and 48% for off-grid (standalone) connections. The literature survey and data analysis collected on site were used to evaluate and determine the best cheaper microgrid model from the three comparison case studies for the household in Rwanda. The study focused on the economic power generation model mainly based on solar resources to minimize the electricity cost and provide income for the excess energy produced. Moreover, the study resulted in a low-cost (four times cheaper), reliable, and affordable grid-connected PV and battery microgrid model for a residential home with a minimum daily load of 5.467 kWh. The simulation results based on economic comparison analysis found the levelized cost of energy (LCOE) and net present cost (NPC) for each power-generated model by using Hybrid Optimization Model for Electric Renewable (Homer) pro software. The results show that the LCOE for electricity production by each of the Grid connected-PV-Battery system, Diesel GenSet-PV-Batteries, and PV-Batteries systems was 0.0645 US\$/1 kWh, 1.38 US\$/1 kWh and 1.82 US\$/1 kWh, respectively, compared with 0.2621 US\$/1 kWh, the current residential electricity price (2020) for Rwanda.

1. Introduction

Photovoltaic technology has been an important topic for researchers from the last decade up to date. PV systems are placed into a microgrid as a local electricity distribution system that is operated in a controlled way and include both energy users and renewable energy generation. Other sources of renewable energy are wind, fuel cells, biogas, tidal, and geothermal that can be produced to generate electricity locally [1]. PV microgrid distribution across the globe has been grown while taking advantage of free solar insolation during the day period. However, its variability and uncontrollability are greatly depending on weather conditions. In Rwanda, the minimum global horizontal irradiation is varying from 4.2 up to 5.8 kWh/m² [2]. To avoid the effect of

instant varying solar insolation, a backup energy storage system has been provided by so many authors. For grid-connected systems, the backup will take effect only during the off-peak load hours or during power cut or blackout or any power failure. To evaluate more opportunities, diesel generator has been simulated with photovoltaic system as the other source of energy generating system to find its efficacy. The global studies confirm the continuous increase of the world's total installed photovoltaic capacity up-to-date [3]. In Rwanda, a lot of effort is currently made to sensitize private investors on the implementation of solar energy projects to remove the big gap between electricity demand and power generation capacity [4]. Recently, electrical loads in Rwanda are power supported by diesel generators during heavy peak hours which may rise the fuel electricity cost,

equivalent to 0.2621 US\$/kWh for residential homes consuming above 50 kWh per month [5]. The authors in [6] highlight the drawbacks from diesel generator usage relied on their fuel cost and environment pollution. Three case scenarios were simulated with HOMER software where one is grid-connected and the other two are off-grid systems with and without a diesel generator. The resulting conclusion comes up with a recommended model suitable for enough power production, electrical load capacity, financial costs, and society benefits such as power reliability and affordability and ability to reduce CO₂ emissions. The levelized cost of electricity from PV microgrid supply scheme, LCOE, for each model type has been compared to recent electricity purchase in Rwanda, and the best economic model was chosen. This paper starts by Introduction, Literature Survey, Methodology, Optimization Results and Analysis with Homer Pro Software, Comparison of Different State-of-the-Art Results with the Proposed Study, and finally Conclusion.

2. Literature Survey

Nowadays, some literatures are available for the optimization of renewable energy systems by operating different distribution energy sources [7]. Across the continent, the development of new power sources for fossil fuel replacement, such as renewable energy sources, has given high priority for both economic and environmental advantages. Studies [8, 9] used HOMER to simulate, analyze, and optimize renewable power sources which can substitute conventional energy sources, and the authors confirmed a feasibility solution of a reliable standalone electric power system for people living far from the national grid. For power back-up, different authors use storage systems including battery or inline diesel generator support. [10] used HOMER appliances in the village and show the result of adding renewable generation to the current supply scheme. Sharmin et al. proved that Off-Grid Biogas Power Generation Model for a rural area is feasible by using Homer software tool and confirmed the feasibility of the representation. The authors [11] evaluated both off-grid and grid-connected for a variety of applications and made a cost-benefit study using Homer Pro software tool. However, the study elaborates the analysis of data based on a particular residential home with specific detailed load in Rwanda by using three different alternative PV microgrid models such as a grid-connected system and two standalone systems. The selection choice is based on which model would be reliable, feasible, and affordable for the home with 5.47 kWh load.

3. Methodology

The methodology of the research is based on the economic analysis of three PV microgrid systems based on two principal economic indicators such as total NPC and LCOE for each model design. The first one is a grid-connected photovoltaic system with lithium ion battery. The other two systems are off-grid systems with PV, generator, and battery and are then compared with the purely renewable system with PV and battery only using Homer Pro to find the least

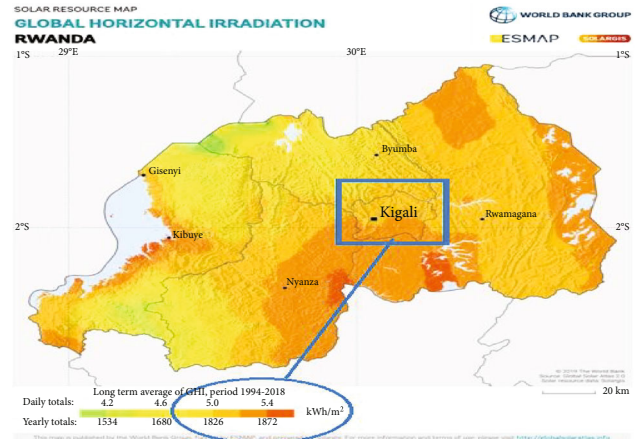

FIGURE 1: Kigali horizontal radiation [2].

LCOE values and minimum net present cost for respective models. Homer Pro software was selected due to its merit to simulate different energy systems, shows system configurations optimized by cost, and finally provides sensitivity analyses on which the authors conclude based on the study purposes.

3.1. Site Profile. The site location is a home located in the city of Kigali, the central capital of, Rwanda, with the geographical coordinates (1°56.6' S, 30°3.7' E) in Kigali city, Africa. Its coordinated universal time (UTC) zone is UTC plus two hours, i.e., [UTC+02]. This is the home location where the data has been taken for model design. Figure 1 indicates the map for the site location with long-term average global horizontal irradiation.

3.2. Load Description. The items and their power rating have been detailed in Table 1. The total load can be split into three different consumption parts. The first part starts from 4:00 AM to 8:00 AM, where both parents and children are staying at home and therefore use some power to prepare morning work. It is their time to use lights, microwave, and iron for preparing the starting of their daily journey. The second part starts from 9:00 AM to 14:00 AM where the load is consumed by watching TV, using a shaver and fridge. The last part comes from 5:00 PM to 21:00 PM where both parents and children come back home from their jobs and they can use high electrical loads such as lights, watching TV, charging phones, and using high-consumption electrical loads like fridge and microwaves as distributed in Figure 2. In this paper, the load profile is considered the energy consumption of the residential home in Kigali city and it is about 5.467 kWh/day as illustrated in Table 1.

The daily distribution of the load is hereby shown in Figure 2. It is clear that a high-power consumption in the morning rises around 7:00 AM and around 13:00 PM and the peak load is observed from 19:00-20:00 PM. The reason of this peak load is justified by the time where the whole family get back home and use much power for their daily needs. It is highly noted that during the peak power period, the sun

TABLE 1: Electrical consumption of equipment and daily energy usage for a home in Kigali city.

Serial number	Item name	Quantity required	Power rating (W)	Hour of use per day	Daily energy usage (Wh)
1	Home lights	8	20	12	1920
2	Computers usage	2	25	6	300
3	TV	1	125	5	625
4	Iron	1	1000	0.5	500
5	Shaver	4	15	0.2	12
6	Mobile phones	4	2.5	5	50
7	Refrigerator	1	150	12	1800
8	Microwave	1	1300	0.2	260
Total daily load profile (watt-hour/day)					5,467

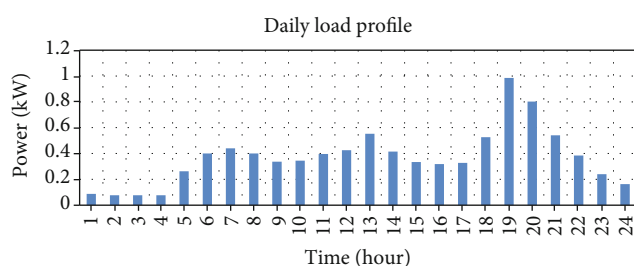

FIGURE 2: Daily electric load distribution for a residential home in Kigali city.

has already been set, which explains the necessity of storage energy resources.

3.3. PV Radiation. The annual average data of the global horizontal radiation (GHI) and clearness index from a residential home obtained with the help of the National Aeronautics and Space Administration (NASA) Surface meteorology database based on the geographical location of KN 4Ave, Kigali, Rwanda, with longitude and altitude here-with shown ($1^{\circ}56.6'S$, $30^{\circ}3.7'E$). At this location, the annual average solar radiation is 5.5 kWh/m^2 and the annual average clearness index is 0.55. As it is shown in Figure 3, the three months with higher solar radiation are February, March, and September with their respective insolation of 5.84, 5.81, and $5.85 \text{ kWh/m}^2/\text{day}$ (2020). During this period, the majority of the sun interchanges with little rain at normal temperature around 25°C . A measurement of atmospheric clearness noted as clearness index is averaged to 0.55 from to its highest possible value of 1.0, which means the study site is mostly clear and sunny.

3.4. Selection of PV System. The following PV specifications were chosen based on its design performance. The 295-Watt CS6K-295MS features efficient Passivated Emitter and Rear Contact (PERC) solar cells to significantly improve the performance of its power in morning, evening, and other low light conditions at a low price per watt. The important parameters of the selected PV panel are available in the data-sheet of the manufacturer's website, and it is summarized in Table 2.

3.4.1. On-Grid PV Microgrid System Design. The grid-connected microgrid topology is given by the Monocrystalline solar PV with 295 Wp (Watts peak), CS6K-295MS with 1 kWh string of lithium-ion, ASM battery model with bidirectional converter, and Leonics model supplying the daily minimum load demand of 5,467 kWh. Furthermore, the respective design models were analyzed economically with Homer Pro based on their respective LCOE and NPC values. As stated in different literatures like Dekker, et al. [12], NPC values should be kept minimum as much as possible. The following schematic diagrams are showing different simulation strategies to be evaluated to find a reliable, feasible, and optimum model for Kigali city citizens. Figure 4 illustrates the on-grid microgrid with PV, battery, and converter to feed the AC load demand.

3.4.2. Off-Grid PV Microgrid System Design. The off-grid PV systems, also called standalone PV systems, are relying on solar power as the main power production unit. The following PV microgrid systems consist of a standalone solar system with (Figure 5) or without diesel (Figure 6) to meet the daily load demand of 5,467 Wh of a residential house in Kigali city, the capital of Rwanda. All those system models use batteries for energy storage during periods of poor weather. The charge controllers are also included here—with the solar PV to control the state of charging and discharging of batteries [13]. When batteries are fully charged, they are disconnected from the PV modules and may also be disconnected from the load to protect the batteries from over-discharging. Figures 5 and 6 are the design layout models of, respectively, the off-grid topology with solar PV, generator, and battery systems to feed the AC load demand through a bidirectional converter, while the last model is done with PV and battery system to supply the same AC load demand through the two-way converter. These three cases give an intuition view of the system operation, and the simulations have been done using Homer Pro software.

3.5. Battery. The three model systems designed for the comparison study require all energy storage elements, which is in this manuscript the lithium-ion battery. The battery belongs to the advanced kinetic storage model (ASM) that includes

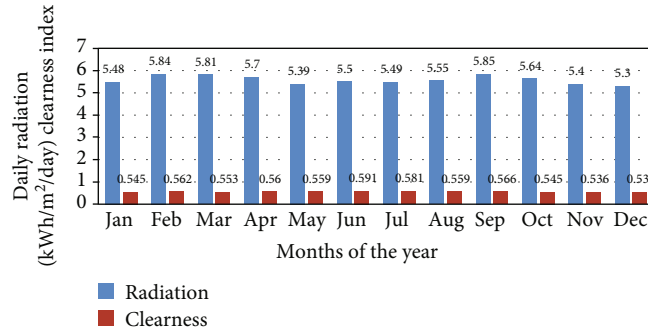

FIGURE 3: Global solar radiation with the corresponding clearness index at Kigali city, Rwanda (data gathered by NASA, Surface Solar Energy database, 2020).

TABLE 2: Parameters of CS6K-295MS PV Module at Standard Test Conditions (STC) and temperature = 25°C and insolation = 1000 W/m².

Solar model	CS6K-295MS
STC rating	295 W
Efficiency	18.02%
Open circuit voltage (V_{oc})	39.5 V
Short circuit current (I_{sc})	9.75A
Optimum operating voltage (V_{mp})	32.3 V
Optimum operating current (I_{mp})	9.14 V

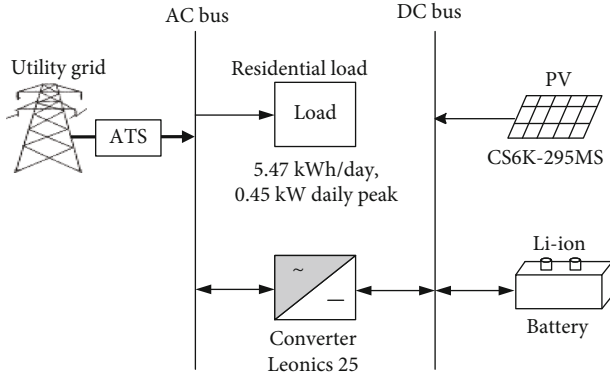

FIGURE 4: Layout diagram for on-grid power system with PV, battery and converter.

rate-dependent losses, temperature dependence on capacity, cycle lifetime estimation using rain flow counting, and temperature effects on calendar life. In the model design, the capacity and configuration of the battery must be evaluated so that it can work with respect to the system requirements. The sizing of the battery for two days of autonomy is herein calculated by using the nominal voltage of 12 V/100 Ah that is mostly used in solar panels. Table 3 indicates the worst scenario of battery and solar sizing in the zone without grid utility for a home load of 5,467 Wh.

3.6. Utility Grid. The national utility for major power production is from hydropower plants (53%), and the current power is 224.6 MW distributed to an estimate of 51% (37% on-grid

and 14% off-grid) of the total of 12.5 million of the population [4]. Rwanda has a plan to increase electricity access in 2024 to a total of 556 MW that will be able to supply power to 100% of inhabitants. Among them, 52% are targeting on-grid while 48% will be off-grid [14].

The cost of electrical energy to be purchased from the national utility grid is annually revised, and it is currently US\$ 0.2621 per each 1 kWh purchased and US\$ 0.15 per each kWh of solar sold back to the grid.

3.7. Economic Cost Optimization of the System. In this paper, the grid-connected system with PV and battery system gives the most promising results for Kigali city inhabitants. The selection of the best model is done based on the economic analysis of the system with the lowest levelized cost of energy (LCOE) and the total net present cost (NPC). The NPC of a component is also called life-cycle cost as it was explained in Homer Pro user manual (2020), which includes the costs of installing and operating the component over the project lifetime, subtracting the present value of all revenues earned over the project lifetime. The system costs here include the capital cost, replacement cost, operation and maintenance costs, fuel costs, emissions penalties, and the cost for power purchase from the grid while the salvage and grids sales are revenues [15]. Despite the low values of LCOE and NPC which are one of the indicators of feasibility study, the availability of natural resources at the investigated location is also considered while deciding on the reliability and feasibility of the power system. There are places which are rich in wind, fuels, and gas energy but which may be poor in solar energy or are having potential in both wind and solar. The decision of the best power system model is therefore done on case basis depending on which energy resource is dominating in the study location. In Homer optimization results, the lower is the LCOE, the lower is the electricity tariff. Similarly, the lower is the NPC imply, the lower is the initial investment required to initiate the energy infrastructure. The NPC is mathematically derived, while the levelized cost of energy (LCOE) value to a certain extent is arbitrary making the NPC more reliable [16, 17].

3.8. Mathematical Analysis Relied on the Power System Cost Minimization System. The optimization of each power system is done using HOMER software for finding the feasibility

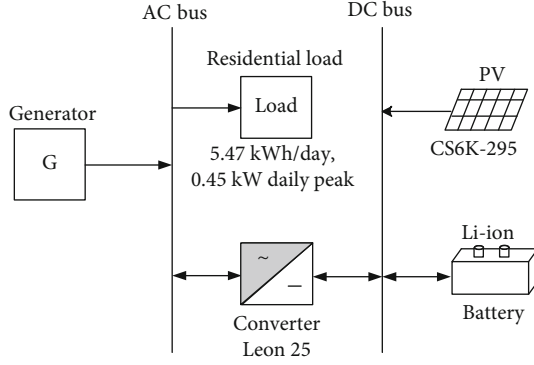

FIGURE 5: Layout diagram for off-grid power system with generator, PV, battery and converter.

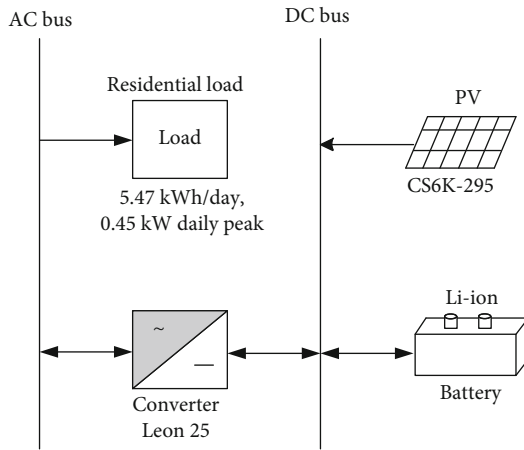

FIGURE 6: Layout diagram for off-grid power system with PV, battery and converter.

cost by referring to the following cost minimization procedure. Each schematic model among the three categories will undergo the minimization steps using the below formula. The following is an example of a photovoltaic grid-connected system with a battery to supply the AC load demand.

Let the function (f) be expressed in the cost of each installed component (x).

$$f(x) = Cc + Rc + Mc + ChBc, \quad (1)$$

where Cc is the capital cost, Rc is the replacement cost, Mc is the maintenance cost, and $ChBc$ is the charging battery cost. Equation (1) can be detailed as follows:

- (i) Capital cost (Cc): capital cost symbolizes the total installed cost of each component (PV panels, battery, charge controller, power converter, and cabling) at the beginning of the project.

$$ChBc = E_{\text{Grid-Bat}} * c_h. \quad (2)$$

Equation (2) represents the amount of money to be spent in order to charge the battery from the main energy source during its availability and $E_{\text{Grid-Bat}}$ is the amount of energy extracted from the grid for the charging process, while c_h defines the cost of kWh imposed by the utility power providers.

It is required to find the value of the annuity based on the interest rate (i_L) and the period ($h \leq n$) of the payment using the term known as capital recovery factor (CRF).

$$\text{CRF}(i_L, h) = \frac{i_L(i_L + 1)^h}{(i_L + 1)^h - 1}. \quad (3)$$

The total capital cost (TCc) is the sum (\sum) of each component as it was derived from [16].

$$\text{TCc} = \sum_{co} Cc_{co} * \text{CRF} * h, \quad (4)$$

where “co” is the installation components and “ Cc_{co} ” is the capital cost of a specific component which depends on the number of installed components.

- (ii) Replacement cost (Rc): the cost related to component changes in the worst scenario. An example may be a battery that may be replaced more than once during the lifetime of the project (R_{Bat}).

$$Rc = n_{\text{Bat}} * R_{\text{Bat}} * \text{SFF} * n, \quad (5)$$

where n is the project lifetime (Yr.) and it is estimated to be 25 years for PV systems; n_{Bat} is the number of installed batteries; R_{Bat} is battery replacement during the lifetime of the project; and SFF are the sinking fund factors. It allows the computation of the real amount of money that can be spent while considering the interest rate of the saving account. It is mostly used when the future payment is forecast.

$$\text{SFF} = \frac{i_L}{(1 + i_L)^n - 1}, \quad (6)$$

where i_L is the interest rate offered by a bank for a saving account. It is also called real discount rate (%).

- (iii) Maintenance cost (Mc): the total maintenance cost (TMc) of each component of the system is generally set to a value of 1% of its capital cost. It depends on the inflation rate (i_r) and the final value of the payment (FVA) over the project's lifetime (n) after adding the inflation rate.

$$\text{FVA} = \frac{(1 + i_r)^n}{i_r + 1} \quad (7)$$

$$\text{TMc} = \sum_{co} Mc_{co} * \text{FVA}.$$

TABLE 3: The sizing of PV, battery, and converter to supply power to AC load. This case can well fit in regions far from the national utility.

Load demand: 5467 Wh	Battery needed Li-ion (ASM) 12 V/100 Ah with DoD 100%	Solar panels needed for off-grid systems with 5.5k Wh/m ² yearly radiation
Load by considering two days of autonomy: 10934 Wh	1200 Wh need to charge this load for one day with 10934/1200 = 9.1 or 10 strings which makes battery size of 10 * 1200 Wh = 12,000 Wh	We consider solar irradiance of 1000 W/m ² with 5.5 hours of solar availability
The site where data was collected manifests clearness index of 0.55 (Figure 3) which is a good indicator for clear and sunny region, so two days of autonomy is a good approximation to minimize the battery cost in this design	The 10 strings of batteries will be connected in parallel to make a battery bank be able to accumulate maximum solar charges. It is noted that the battery is the only component that is mostly expensive, and they need a replacement before the lifetime of solar photovoltaics	Solar panel capacity: 12,000 Wh/5.5 h = 2181.8 W. Using this CS6K-295MS solar, we get minimum of 2182/295 = 7.4 or simply 8 solar panels to meet the daily load demand

The optimization problem is constrained by the technical constraints in Homer Pro optimization tool and by the maintenance of a permanent power supply of the residential house load and thus maintaining a nil loss of power supply probability (LPSP). It can be important to compute the loss of power supply (LPS_h) when the energy produced by the PV panels and the energy stored in batteries are not sufficient to meet the load demand. The PV output is served as input to battery and the battery output to DC/AC inverter which feeds the load through AC bus. Its formula is given by the following expression:

$$LPS_h = E_{Load,h} - (E_{PV,h} + E_{Bat,h-1} - E_{Bat,min}) * \eta_{inv}, \quad (8)$$

where η_{inv} is the inverter efficiency; $E_{Load,h}$ is the amount of energy consumed by the load at step period h ; $E_{PV,h}$ is the amount of energy produced by the PV panels at step period h ; $E_{Bat,h-1}$ is the amount of stored energy in battery bank at the previous period $h-1$; and $E_{Bat,min}$ is the minimum amount of battery energy to maintain its depth of discharge.

$$LPSP = \frac{\sum_h LPS_h}{\sum_h E_{Load,h}}. \quad (9)$$

The optimization problem from of the PV-battery backup system is then summarized as follows:

$$\begin{cases} \text{minimize } f(x) = Cc + Mc + Rc + ChBc \\ x \text{ is subjected to } LPSP = 0 \\ P_{Load,h} \leq P_{max}; \text{ for all } h \end{cases} \quad (10)$$

where $P_{Load,h}$ is the amount of power consumed by the load at step period h and P_{max} is the contracted power limit of the utility grid and it is a fixed preset threshold. To maximize the output of PV microgrid and protect the state of charge of battery within the prescribed limits of charging and discharging, a PV charge controller is used. In Homer software, the charge controller cost is not separated from the PV

panels. The efficiency of charge controller n_{chco} can be computed as follows:

$$n_{chco} = \frac{P_{mpp} * n_{PV}}{i_{chco} * V_{sys}}, \quad (11)$$

where i_{chco} is the rated current of the charge controller, P_{mpp} is the maximum power of PV panels, n_{PV} is the number of PV panels to make PV array, and V_{sys} is the system bus voltage. In Homer software, the charge controller is not separated from the PV panels.

4. Optimization Results and Analysis with Homer Pro Software

With Homer Pro software, three case studies are analyzed for a residential home of 5,467 kWh/day in Kigali city with the following components: The national utility grid price per unit (0.2621 US\$/kWh) [5], Canadian solar superpower CS6K-295MS, Generic 1kWh Li-ion Battery of ASM model, and the System converter with the model Leonics, MTP-413F.

The following are the detailed cost summary results obtained from simulations with Homer Pro for the three respective schematic models.

4.1. Case I: Grid (999,999 kW)-CS6K-295MS (18 kW)-Li-ion (1kWh) and Leonics-MTP-413F (25 kW). In this case, the proposed microgrid was optimized in Homer Pro with components such as solar Canadian model CS6K-295MS (18 kW) for a cost of 37,800 US\$, i.e., 2.1 US\$/1 watt, battery model Li-ion (1 kWh) for a cost of 700 US\$, and utility grid that is highly depending on monthly bills. Through the converter model, Leonics MTP-413F (25 kW) at a cost of 15,000 US\$, a residential load demand of 5.467 kW, was supplied. The total system requires investments of 53,500 US\$. The simulation results are NPC of 22,155 US\$ and LCOE of 0.0645 US\$/kWh. Operating and replacement cost is evaluated to 43,041 US\$, and 13,549 US\$, respectively. The system salvage results in 1,853 US\$ from the converter contribution of 1,797 US\$, and battery's salvage is 55.9 US\$. Figure 7 gives the

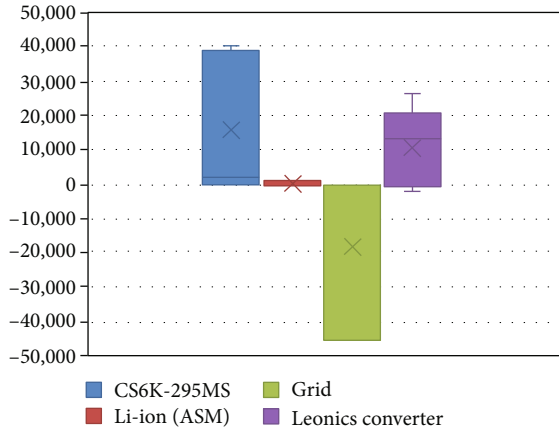

FIGURE 7: Cost summary (US\$) results for PV (CS6K-295MS), battery (Li-ion), grid, and converter system.

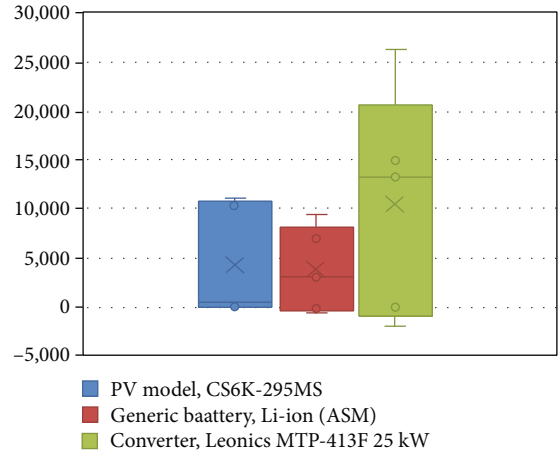

FIGURE 9: Cost summary (US\$) from Homer Pro simulation results for PV, battery, and converter.

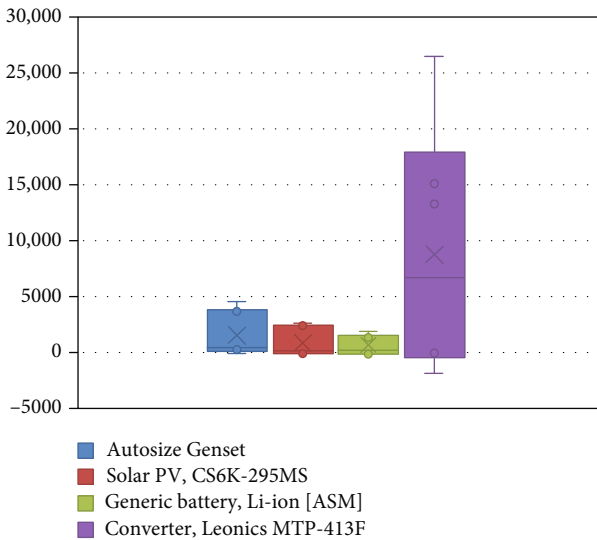

FIGURE 8: Cost summary (US\$) from Homer Pro simulation results for PV, generator, battery, and converter.

details of the cost contribution in US\$ for each component in the system. The roles of PV and converter are mentioned with big contribution in supplying load demand. The outputs of PV and Battery are all DC power which are converted into AC power through the converter model (Leonics MTP-413F, 25kW) to both feed the AC load and producing the excess power to sell back to the grid. The Homer Pro optimization software minimized the low usage of batteries which may be only needed during power back up or peak hour period. The PV and converter manifest high cost contribution in the system. The system is designed to minimize the grid cost and therefore put much focus to renewable energies usages by regulating the automatic transfer switch (ATS). The battery contribution is low in order to minimize the system cost. Figure 7 illustrates the cost summary (US\$) of PV (CS6K-295 MS), battery (Li-ion), grid connected, and converter system.

The installed capacity that is explored in Case I resulted in electrical energy production of 27,647 kWh/year of which

the solar PV (CS6K-295MS) produce 26,973 kWh/year, i.e., 97.6% with Grid purchases equivalent to 673 kWh/year, i.e., 2.43%. Among the total energy produced, only 1,995 kWh/year, i.e., 7.51% is dedicated to AC load demand while the remaining 24,815 kWh/year, i.e., 92.6% has been sold to the grid. This justify why the solar PV for the grid connected PV system is highly rated (up to 18kW) with its corresponding converter (25kW) while in the case of the other two off-grid systems, their power ratings are exactly matching the load requirement. The energy purchased from the grid is much lower than the energy sold to the Grid. This motivate the PV microgrid owner to stack on solar PV energy production in the country where the energy sells and buy policy is well structured.

4.2. Case II: Generator (1.3 kW)-CS6K-295MS (1.69 kW)-Li-ion Battery (5 kWh)-Leonics-MTP-413F (25 kW). Case II proposes PV microgrid with their components such as diesel generator (0.5 kW) for the cost of 4,650 US\$, solar PV model CS6K-295MS (1.16 kW) for a cost of 2,597 US\$, battery model Li-ion (2 kWh) for a cost of 1,903 US\$, and the converter model, Leonics MTP-413F (25 kW) for a cost of 26,455 US\$ which are all designed to supply the residential load demand of 5.467 kW/day. The total system requires investments of NPC of 35,605 US\$ to raise the LCOE of 1.38 US\$/kWh. To meet the AC load demand while minimizing the high fuel cost of generator, the converter contribution is more enormous than other components due to its high task to invert the DC power output from both PV and battery into their equivalent AC power. Although the initial capital is relatively small with 19,096 US\$, there is an additional great cost mainly related to generator component, battery, and converter replacement equivalent to 361.97 US\$, 603.82 US\$, and 13,252 US\$, respectively. The operation, salvage, and resources are, respectively, given by 577.78 US\$, 1,917 US\$, and 3,631 US\$ for an estimated lifetime of more than 25 years. It is noted that the salvage is the value remaining in a component of power system at the end of the project lifetime. Figure 8 shows the cost contribution for each component.

TABLE 4: Comparison of different state-of-the-art results based on economic analysis and the proposed approach.

Reference	Study location & irradiation (kWh/m ² /d)	Model architecture with power ratings	Principal economic indicators (cost units)			Electrical production and/or power consumption.	
			Initial capital cost	Operating cost (\$/Yr.)	NPC		LCOE
[18]	Baru Sahib in India & [7.57]	PV: 6 kW DG: 3 kW Converter: 1 kW Case A: hybrid (PV-FC) PV: 2 kW FC: 0.1 kW Electrolyzer: 0.5 kW BT: 8 Converter: 1 kW Case B: Hybrid (WT-FC) WT: 10 kW FC: 0.1 kW Electrolyzer: 1.5 kW BT: 24 Converter: 0.5 kW	11,530\$	5,067	76,307\$	1.211\$/kWh	Consumption (kWh/Yr.) AC load demand: 13kWh/day with 2.5 kWp Production (kWh/Yr.) PV: 2416, i.e., 98% FC: 52, i.e., 2% Consumption (kWh/Yr.) AC load: 1095, i.e., 57% Electrolyzer load: 822, i.e., 43% Production (kWh/Yr.) WT: 5,111, i.e., 98% FC: 92, i.e., 2% Consumption (kWh/Yr.) AC load: 1,095 i.e.43% Electrolyzer load: 1,442, i.e., 57%.
[19]	Residential load of Sunderbans in India & [4.978]	Case C Hybrid (PV-WT-FC) PV: 0.5 kW WT: 10 kW FC: 0.1 kW Electrolyzer: 1 kW BT: 8 Converter: 0.5 kW	31,450\$	1,512\$	50,785\$	3.628\$/kWh	Production (kWh/Yr.) PV: 604, i.e., 10% WT: 5,111 i.e.88% FC: 106, i.e., 2% Consumption (kWh/Yr.) AC load: 1,090, i.e., 39% Electrolyzer load: 1,714, i.e., 61%
[20]	Technical (Matlab) and economic (Homer Pro) Papua in Indonesia & [4.74]	Pure PV BT: 12 V/100 Ah Pure DG Hyd: 10 kW WT: 100 kW PV: 10 kW Hyd (1Turbine): 10 kW PV: 1.09 kW Converter: 10 kW Hyd: 10 kW WT: 100 kW WT: 100 kW PV: 10 kW	C _{BT} : 186.19\$ 0.54\$/l L	— —	203,271\$ 320,661\$	0.64\$/kWh 1.17 \$/kWh (1\$ =14,877.22Rp)	Load consumption (kWh/day) AC load: 45.6
[21]	Off-grid rural electrification in Rwanda & [5.4]		C _{WT} : 80,000\$ C _{Hyd} : 20,000\$ C _{PV} : 16,000\$ C _{BT} (1 kWh each): 2,400\$; C _{Converter} : 30,000\$	1,495.49\$	41,210.80\$	0.0560\$/kWh	Production (kWh/Yr.) Hyd: 122,716, i.e., 98.7% PV: 1,620, i.e., 1.3% Consumption (kWh/day) AC load: 158.1 Peak: 18 kW

TABLE 4: Continued.

Reference	Study location & irradiation (kWh/m ² /d)	Model architecture with power ratings	Initial capital cost	Operating cost (\$/Yr.)	NPC	LCOE	Electrical production and/or power consumption.
[22]	Rural area in the southern city of Bangladesh	Hybrid (Grid-PV-WT) Grid: 999,999 kW PV: 150 kW WT (3 WGs) Converter: 180 kW Off-grid (WT-PV)	600,000\$	-4,977\$	535,661\$	0.0995\$/kWh	Production (kWh/Yr.) WT: 124,625, i.e., 28.57% PV: 198,814, i.e., 45.58% Grid purchases: 112,747, i.e., 25.85% Consumption (kWh/Yr.) AC load: 238,976, i.e., 57.4% Grid sales: 177,328, i.e., 42.6% Production (MWh/Yr.) PV: 1052.68, i.e., 52% FC: 980.32, i.e., 48% Consumption (MWh/Yr.) AC load: 238,976, i.e., 80.7% Electrolyzer load: 286.37, i.e., 14.08% Excess power: 37.53, i.e., 1.8% Losses in power conversion: 68.37, i.e., 3.3%
[23]	The hybrid (PV-FC) power system residential community in Sharjah (150houses)	PV: 517 kW FC: 750 kW H ₂ tank: 900 kg Inverter: 738 kW	—	—	3.07 million\$	145\$/MWh	Upington city results RF: 0.75 Lowest diesel used: 1,267 [L/year] at (0.7\$/1 L) & 1,275 [L/year] at (0.9\$/1 L) Lowest emission of CO ₂ 3,336 [tons/year] for diesel 1 price (0.7\$/1 L) 3,359 [tons/year] for diesel 2 price (0.9\$/1 L) Existing LCOE: 0.5352\$/kWh The improvement: 0.2332\$/kWh Load consumption: 6,632.86kWh/day with 476.23 kWp The improvement: 0.2234\$/kWh Load consumption: 3,830.07kWh/day with 417.55 kWp
[12]	HPSS for typical residential loads for the rural community in South Africa.	PV: 5 kW BT (30): 720 Ah Regulator: 12/24 V, 5A DG: 5.5 kW, 50 Hz @ 3,000 rpm Converter: 6 kW	C _{PV} : 4,250\$ C _{BT} : 269\$ C _{Fuel} : 15,398\$ (0.7\$/L) C _{Fuel2} : 32,990\$ (0.9\$/L) C _{DG} : 313\$ C _{Converter} : 3,731\$	—	62,402\$ for (0.7\$/L) 65,833\$ for (0.9\$/L)	—	
[16]	Solar radiation averaging [4.8–6.1]	Optimized Hybrid 1PV/(G1-G5) Diesels/Battery system (42.38% RE)	—	536,081\$	9,345,510\$	0.302\$/kWh	
	Solar radiation averaging [4.8–6.1]	Optimized Hybrid 1PV/(G1-G3) Diesels/Battery system (39.89% RE)	—	302,203\$	5,571,168\$	0.312\$/kWh	

First site location: Pulau Banggi in Malaysia

Second site location: Tanjung Labian in Malaysia

TABLE 4: Continued.

Reference	Study location & irradiation (kWh/m ² /d)	Model architecture with power ratings	Initial capital cost	Operating cost (\$/Yr.)	NPC	LCOE	Electrical production and/or power consumption.
[24]	Khorramabad in Iran (data of 2012) Solar radiation averaging [5.15]	C_{PV} : 6,900\$ C_{FC} : 2,500\$ C_{H2Tank} : 1,200\$ $C_{Electrolyzer}$: 1,500\$-3,000\$ C_{WT} (1.24 kW): 3,900\$ PV: 6,900\$ WT(1.24 kW): 3,900\$ DG (0.25\$/L): 3,500\$ Bat:6 V/1.156 ah: 1,200\$; converter (efficiency:90%): 800\$ Optimal design: Puerto Estrella	215,500\$	3,910\$	234,843\$	7.367\$/kWh	Scheme A is not economical due to low efficiency of fuel cells Residential load consumption: 19 kWh/day with 2.6 kWp Scheme B: Economical and recommended by the authors. Residential load consumption 19 kWh/day with 2.6 kWp
	Off-grid with PV, WT, DG	PV: 160 kW WT: 10 kW DG: 25 kW BT: 250 Converter: 80 kW	521,078\$	24,652	836,210\$	0.473\$/kWh	Energy production (kWh/Yr.) PV: 180,475 DG: 2,789 WT: 2,988 CO ₂ emission: 3,169 kg/Yr. RF: 0.99
[25]	Off-grid with PV, DG	PV: 100 kW DG: 25 kW BT: 100 Converter: 30 kW Optimal design for Unguia	227,350\$	11,373	372,736\$	0.444\$/kWh	Electricity consumption: 379 kWh/day with 88 kWp Energy production (kWh/Yr.) PV: 180,475 DG: 4,553 CO ₂ emission: 5,120 kg/Yr. RF: 0.98
	Off-grid with PV, DG.	PV: 150 kW DG: 25 kW BT: 100 Converter: 40 kW Optimal design: Jerico	268,100\$	12,855	445,207\$	0.488 \$/kWh	Electricity consumption: 180 kWh/day with 38 kWp Energy production (kWh/Yr.) PV: 267,345 DG: 5,250 CO ₂ emission:5923 kg/Yr. RF:0.98
[26]	Taleghan in Iran	PV: 0.8 kW WT (×2): 0.4 kW each Inverter: 2.5 kW BT (12 V/200 Ah): 8	22,998\$	218	24,625\$	1.655\$/kWh	Electricity consumption 213 kWh/day with 41 kWp Energy production (kWh/Yr.) PV: 1,234 (41%) WT: 1,794 (59%) Energy consumption (kWh/Yr.) AC primary load: 1992, i.e., 100%

TABLE 4: Continued.

Reference	Study location & irradiation (kWh/m ² /d)	Model architecture with power ratings	Principal economic indicators (cost units)			Electrical production and/or power consumption.
			Initial capital cost	Operating cost (\$/Yr.)	NPC	
Irradiation: [4.8]						
Off-grid connection hybrid system						
[27]	Case A	DG: 10 kW BG: 15 kW	C_{BG} : 1,600\$/1 kW	123,668\$	0.145- 0.119\$/kWh	RF: 0.93 Load consumption: 117- 186 kWh/day with 19 kWp
	Case B	PV: 5 kW BT: 20 kW Converter: 15 kW	C_{PV} : 2,800\$/1 kW	172,003\$	0.129\$/kWh	RF: 1, i.e., 100% Load consumption: 152- 242 kWh/day with 25 kWp
	Case C	DG: 10 kW BG: 15 kW PV: 5 kW BT: 20 kW Converter: 10 kW BG: 35 kW	C_{DG} : 370\$/1 kWh C_{BT} : 1,295\$ $C_{Converter}$: 1,000\$/1 kWh	217,551\$	0.12\$/kWh	RF: 1, i.e., 100% Load consumption: 248- 392 kWh/day with 41 kWp
Grid-connected hybrid system						
[28]	Case A	Grid: 100 kW BG: 15 kW	—	82,822\$	0.064\$/kWh	Energy production Grid purchase: 9% Grid sales: 23% RF: 0.91
	Case B	Grid: 100 kW BG: 15 kW	—	79,538\$	0.064\$/kWh	Load consumption: 178 kWh/day with 19 kWp Energy production Grid purchase: 10% Grid sales: 28% RF: 0.90
	Case C	Grid: 100 kW BG: 30 kW	—	134,270\$	0.064\$/kWh	Load consumption: 182 kWh/day with 25 kWp Energy production Grid purchase: 11% Grid sales: 5% RF: 0.89
Agricultural village in Pakistan & Irradiation: [5.18-6.95]						
[28]		PV: 10 kW BT: 32 × 1 kWh Converter: 12 kW BG: 08 kW	16,057.31\$, i.e., 2.64 M (Rs) 1\$ = 164.41 Rs (2020)	864.32, i.e., 142,103 (Rs) 4.48 M (Rs)	0.034\$/kWh or 5.51 Rs/kWh	Load consumption: 86 kWh/day with 41 kWp Electricity production (kWh/Yr.) PV: 16,872, i.e., 24.6% BG: 57,721, i.e., 75.4% Consumption (kWh/Yr.) AC primary load: 65,372, i.e., 100%

TABLE 4: Continued.

Reference	Study location & irradiation (kWh/m ² /d)	Model architecture with power ratings	Principal economic indicators (cost units)			Electrical production and/or power consumption.
			Initial capital cost	Operating cost (\$/Yr.)	NPC	
The proposed study	Residential home in Rwanda & Irradiation: [5.5]	Case I PV: 18 kW BT: 1 × 1 kWh Converter: 25 kW Grid: 999,999 kW	53,500\$	-2,397*	22,155\$	0.0645\$/kWh
		Case II DG: 0.5 kW PV: 1.16 kW BT (1 kWh): 2 Converter Leonics model: 25 kW	19,096\$	1,277	35,605\$	1.38\$/kWh
		Case III PV: 5 kW BT (1 kWh): 10 Converter Leonics model: 25 kW	32,500\$	1,123	7,012\$	1.82\$/kWh
		Case I: on-grid PV microgrid system design				Electricity production (kWh/Yr.) PV: 26,973, i.e., 97.6% Grid purchase: 673, i.e., 2.4% EIRR: 2.47% Payback period: 18.1 Yrs. Consumption (kWh/Yr.) AC primary load: 1,995, i.e., 7.5% Grid sales: 24,572, i.e., 92.5%
		Case II and Case III: off-grid PV microgrid system design				Electricity production (kWh/Yr.) Excess electricity: 537 PV: 1,746, i.e., 65.8% & DG: 906, i.e., 34.2% Consumption (kWh/Yr.) AC primary load: 1,995, i.e., 100% Fuel used: 275 L/0.3 L/kWh. Electricity production (kWh/Yr.) Excess electricity: 5,349 PV: 7,493, i.e., 100% Unmet electric load: 1.33 Consumption (kWh/Yr.) AC primary load: 1,994, i.e., 100%

PV: photovoltaic array; Hyd: hydropower; WT/G: wind turbine/generator; FC: fuel cell; DG: diesel generator; BG: biomass generator; BT: battery; RF: renewable fraction; C_{op} : operational cost (*i.e., $C_{op} = C_{Annual, total} - C_{Annual, capital}$); EIRR: economic internal rate of return. Annual costs are less than revenues.

The electrical and production summary from the Case II analysis are herewith explained in details:

The excess electricity produced was 537 kWh/year. There was no capacity shortage or unmet electric load. The solar PV (CS6K-295MS) produces 1,746 kWh/year, i.e., 65.8%, while the generator produces 906 kWh/year, i.e., 34.2%. The total annual power production of 2,652 kWh has been able to meet the load requirement by 100%. No energy excess or overproduction was observed. However, for a land locked country, like Rwanda, this system is not advisable since its NPC and LCOE are higher than Case I.

4.3. Case III: PV Power CS6K-295MS (5 kW)-Li-ion (1 kWh) for 10 Strings and Leonics MTP-413F (25 kW). The last case is the PV microgrid with all parts are renewable. The system has been optimized in Homer Pro with components such as Solar Canadian model CS6K-295MS (5 kW) for a cost of 11,146 US\$, Battery model Li-ion (1 kWh) for a cost of 10 strings equivalent to 9,411 US\$, and the converter model, Leonics-MTP-413F (25 kW) for a cost of 26,455 US\$ and thus supplies the residential AC load demand of 5.467 kWh/day. The total system requires investments of NPC of 47,012 US\$ to get LCOE of 1.82 US\$/kWh. The converter cost contribution is similarly high as in Case II, which is followed by the solar PV array cost of 5 kW and 1 kWh battery for 10 string cost.

The operating and replacement costs are 646.38 US\$ and 16,221 US\$ of which 82% are due to converter and 18% are dedicated to battery cost replacements. The salvage was equal to 2,356 US\$ with no resources. Figure 9 gives the result details.

The electrical and production summary from the Case III analysis is herewith detailed below:

The system produced the excess electricity of 5,349 kWh/year with 1.33 kWh/year of capacity shortage and 1.95 kWh/year of unmet electric load. The solar PV (CS6K-295MS) produces 7,493 kWh/year, i.e., 100% to meet the yearly load consumption of 1994. Although this is 100% renewable energy system, the economic indicators obtained do not permit it to be advisable in the proposed study when compared to Case I. The manual calculation in Table 3 met the simulation results on the required number of batteries needed for the model design for the total off-grid systems.

5. Comparison of Different State-of-the-Art Results with the Proposed Study

Table 4 shows the state of art of different studies using the various renewable energy resources and their results have been compared with the proposed study while focusing on two principal economic indicators. Two fundamental economic parameters such as net present cost (NPC) and leveled cost of energy (LCOE) have been set as the economic indicator for deciding the feasibility studies of the respective models' design. Other important parameters such as initial capital cost and operating cost have been reviewed. Those concluding parameters should be optimally minimized as much as possible in order to lower the cost of

energy while providing reliable and feasible energy solutions to the citizens.

6. Conclusion

This study demonstrated the comparison analysis of three designed schematic models. One model is the grid-connected system with PV and battery (Figure 4) and the other two models are the off-grid system with PV-battery-diesel (Figure 5) and PV-battery only (Figure 6). With Homer Pro optimization results, it was possible to decide which layout is reliable, feasible, and benefiting the residential home in the city of Kigali based on the lowest fundamental and economic indicators. The results show the grid connected system in Figure 4 is able to meet the load demand on the lowest LCOE of 0.0645 US\$/kWh and the NPC of 22,155 US\$. The electricity price is four times cheaper than the current national electricity tariff. The system model provides more benefits such as the excess of PV microgrid energy produced at rate of 97.6% and the grid sales equivalent to 92.5%. This system has very low energy purchase of 2.4% from the grid, and it is meeting the load requirement of 7.5%. The more additional benefit from Figure 4 model is its excellent impact on the environmental weather due to the high rate of PV microgrid usage to supply the load demand. It has better economic impact due to its possibility to sell the excess power produced during the sunny period and the low peak hours. Therefore, it is highly recommended for this study. The other results from Figures 5 and 6 are, respectively, the LCOE of 1.38 US\$/kWh and NPC of 35,605 US\$ and LCOE of 1.82 US\$/kWh with NPC of 32,500 US\$. The contribution results of Figure 5 are 65.8% and 34.2% of solar PV and Diesel Generator's electrical energy production to supply the daily load demand of 5.47 kWh. The model produces 537 kWh/year of the excess electricity, but due to the geographical location of Rwanda which make it a land locked country with the unavailability of fuel to maintain the normal operation of diesel generator, it is not the best choice. The remaining contribution results are from the Figure 6 model where the system is 100% solar PV usage with a string of ten batteries for energy backup during the period of solar power failure to meet the designed load. The Figure 6 model has an annual of 1.33 kWh of unmet electric load with 5,349 kWh of the excess of electricity production. Although the model is excellently renewable, it may not be easy for a low or a middle-income population to handle its higher electricity tariff. Therefore, it is not recommended in this study.

Data Availability

The data used to support the study was given in supplementary files as Case 1, Case 2 and Case 3.

Conflicts of Interest

The authors declare that they have no conflicts of interest.

Acknowledgments

This work was supported by the key project of Tianjin Natural Science Foundation (Project No. 19JCZDJC32100) and the Natural Science Foundation of Hebei Province of China (Project No. E2018202282).

References

- [1] B. Safari, "A review of energy in Rwanda," *Renewable and Sustainable Energy Reviews*, vol. 14, no. 1, pp. 524–529, 2010.
- [2] Solargis, "The World Bank," 2019, <https://solargis.com/maps-and-gis-data/download/rwanda>.
- [3] J. Dong, M. M. Olama, T. Kuruganti et al., "Novel stochastic methods to predict short-term solar radiation and photovoltaic power," *Renewable Energy*, vol. 145, pp. 333–346, 2020.
- [4] J. D. Dieu Niyonteze, F. Zou, G. N. Osarumwense Asemota, and S. Bimenyimana, "Solar-powered mini-grids and smart metering systems, the solution to Rwanda energy crisis," *Journal of Physics: Conference Series*, vol. 1311, no. 1, article 012002, 2019.
- [5] Rura, "Electricity tariffs in Rwanda," January 2020, https://rura.rw/fileadmin/publication/Press_release_for_Electricity_Tariffs.pdf.
- [6] K. Kusakana and H. J. Vermaak, "Hybrid renewable power systems for mobile telephony base stations in developing countries," *Renewable Energy*, vol. 51, pp. 419–425, 2013.
- [7] M. Fadaee and M. A. M. Radzi, "Multi-objective optimization of a stand-alone hybrid renewable energy system by using evolutionary algorithms: a review," *Renewable and Sustainable Energy Reviews*, vol. 16, no. 5, pp. 3364–3369, 2012.
- [8] A. R. Gautam, K. Gourav, J. M. Guerrero, and D. M. Fulwani, "Ripple mitigation with improved line-load transients response in a two-stage DC-DC-AC converter: adaptive SMC approach," *IEEE Transactions on Industrial Electronics*, vol. 65, no. 4, pp. 3125–3135, 2018.
- [9] D. K. Lal, B. B. Dash, and A. K. Akella, "Optimization of PV/wind/micro-hydro/diesel hybrid power system in HOMER for the study area," *International Journal on Electrical Engineering and Informatics*, vol. 3, no. 3, pp. 307–325, 2011.
- [10] V. B. Mary, I. W. Christopher, and G. Themozhi, "RHES-economic analysis and power management for a technical institution using homer," in *5th International Conference on Electrical Energy Systems, ICEES*, Chennai, India, 2019.
- [11] K. Ajao, O. Oladosu, and O. Popoola, "Summary for Policy-makers," *International Journal of Research and Reviews in Applied Sciences*, vol. 7, no. 1, pp. 96–102, 2014.
- [12] J. Dekker, M. Nthontho, S. Chowdhury, and S. P. Chowdhury, "Economic analysis of PV/diesel hybrid power systems in different climatic zones of South Africa," *International Journal of Electrical Power & Energy Systems*, vol. 40, no. 1, pp. 104–112, 2012.
- [13] Y. Li, M. Vilathgamuwa, S. S. Choi et al., "Design of minimum cost degradation-conscious lithium-ion battery energy storage system to achieve renewable power dispatchability," *Applied Energy*, vol. 260, article 114282, 2020.
- [14] USAID/Power Africa/Rwanda2020. <https://www.usaid.gov/powerafrica/rwanda>.
- [15] Homer Pro, "Homer Pro 3.14 user manual," 2020, <https://www.homerenergy.com/products/pro/docs/latest/index.html>.
- [16] L. M. Halabi and S. Mekhilef, "Flexible hybrid renewable energy system design for a typical remote village located in tropical climate," *Journal of Cleaner Production*, vol. 177, pp. 908–924, 2018.
- [17] N. Pawar and P. Nema, "Techno-economic performance analysis of grid connected PV solar power generation system using HOMER software," in *2018 IEEE International Conference on Computational Intelligence and Computing Research, ICCIC*, Madurai, India, 2018.
- [18] H. Singh, D. Kaur, and P. S. Cheema, "Optimal design of photovoltaic power system for a residential load," in *Proceedings of the International Conference on Inventive Systems and Control, ICISC*, pp. 9–12, Coimbatore, India, 2017.
- [19] S. Dey, R. Dash, and S. C. Swain, "Optimal design and feasibility study of renewable hybrid energy systems," in *1st International Conference on Emerging Trends in Engineering, Technology and Science, ICETETS*, Pudukkottai, India, 2016.
- [20] A. I. Malakani, D. Handoko Arthanto, B. G. Dwi Wicaksono, and A. Purwadi, "Study and design of off-grid PV power system in Piriien, Asmat Regency, Papua Province using MATLAB/SIMULINK," *Proceedings of the 2nd International Conference on High Voltage Engineering and Power Systems: Towards Sustainable and Reliable Power Delivery, ICHVEPS*, 2019, pp. 339–343, Denpasar, Bali, Indonesia, 2019.
- [21] J. D. D. Niyonteze, F. Zou, G. Norensa Osarumwense Asemota, S. Bimenyimana, and G. Shyirambere, "Key technology development needs and applicability analysis of renewable energy hybrid technologies in off-grid areas for the Rwanda power sector," *Heliyon*, vol. 6, no. 1, article e03300, 2020.
- [22] M. Nurunnabi and N. K. Roy, "Grid connected hybrid power system design using HOMER," in *Proceedings of 2015 3rd International Conference on Advances in Electrical Engineering, ICAEE*, pp. 18–21, Dhaka, Bangladesh, 2015.
- [23] C. Ghenai, T. Salameh, and A. Merabet, "Technico-economic analysis of off grid solar PV/fuel cell energy system for residential community in desert region," *International Journal of Hydrogen Energy*, vol. 45, no. 20, pp. 11460–11470, 2020.
- [24] M. Jahangiri, O. Nematollahi, A. Sedaghat, and M. Saghafian, "Techno-economical assessment of renewable energies integrated with fuel cell for off grid electrification: a case study for developing countries," *Journal of Renewable and Sustainable Energy*, vol. 7, no. 2, 2015.
- [25] A. Haghghat Mamaghani, S. A. Avella Escandon, B. Najafi, A. Shirazi, and F. Rinaldi, "Techno-economic feasibility of photovoltaic, wind, diesel and hybrid electrification systems for off-grid rural electrification in Colombia," *Renewable Energy*, vol. 97, pp. 293–305, 2016.
- [26] A. Shiroudi, R. Rashidi, G. B. Gharehpetian, S. A. Mousavifar, and A. Akbari Foroud, "Case study: simulation and optimization of photovoltaic-wind-battery hybrid energy system in Taleghan-Iran usinghomersoftware," *Journal of Renewable and Sustainable Energy*, vol. 4, no. 5, 2012.
- [27] R. Rajbongshi, D. Borgohain, and S. Mahapatra, "Optimization of PV-biomass-diesel and grid base hybrid energy systems for rural electrification by using HOMER," *Energy*, vol. 126, pp. 461–474, 2017.
- [28] M. K. Shahzad, A. Zahid, T. ur Rashid, M. A. Rehan, M. Ali, and M. Ahmad, "Techno-economic feasibility analysis of a solar-biomass off grid system for the electrification of remote rural areas in Pakistan using HOMER software," *Renewable Energy*, vol. 106, pp. 264–273, 2017.