

## Research Article

# Studies on Exhaust Emissions from Copper-Coated Gasohol Run Spark Ignition Engine with Catalytic Converter

**S. Narasimha Kumar,<sup>1</sup> K. Kishor,<sup>1</sup> M. V. S. Murali Krishna,<sup>1</sup> and P. V. K. Murthy<sup>2</sup>**

<sup>1</sup>Department of Mechanical Engineering, Chaitanya Bharathi Institute of Technology, Gandipet, Hyderabad 500 075, India

<sup>2</sup>Vivekananda Institute of Science and Information Technology, Shadnagar, Mahabubnagar 509216, India

Correspondence should be addressed to M. V. S. Murali Krishna, maddalivs@gmail.com

Received 16 January 2011; Accepted 14 March 2011

Academic Editor: K. Ismail

Copyright © 2011 S. Narasimha Kumar et al. This is an open access article distributed under the Creative Commons Attribution License, which permits unrestricted use, distribution, and reproduction in any medium, provided the original work is properly cited.

The major pollutants emitted from spark ignition engine are carbon monoxide (CO) and unburnt hydrocarbons (UHC). These are hazardous and cause health problems to human beings, and hence control of these pollutants calls for immediate attention. Copper of thickness 300 microns is coated over piston crown and inside portion of the cylinder head of the spark ignition engine. Investigations have been carried out for reducing pollutants from a variable compression ratio, copper-coated spark ignition engine fitted with catalytic converter containing sponge iron catalyst run with gasohol (blend of 20% ethanol and 80% gasoline by volume). The influence of parameters such as void ratio, airflow rate, temperature of injected air, speed, compression ratio, and load of the engine on these emissions are studied. A microprocessor-based analyzer is used for the measurement of CO/UHC in the exhaust of the engine. The speed, load, compression ratio and the injection of air into the catalytic converter are found to show strong influence on reduction of the pollutants in the exhaust. Copper-coated spark ignition engine with gasohol operation reduced the exhaust emissions considerably when compared to conventional engine with pure gasoline operation.

## 1. Introduction

Carbon monoxide is major pollutant contributed by the automobile exhaust, particularly spark ignition engine, breathing of which causes many health disorders, like reduction of hemoglobin content in the blood, dizziness, breathing and respiratory problems, eye irritation, and loss of appetite [1, 2]. It also causes detrimental effects on other animal and plant life besides environmental disorders [3]. This pollutant is considerably high during idling and peak load operation of the engine. Further, the CO emissions in the exhaust of 2- and 4-stroke engines increase with the age of the vehicle [4]. Hence, globally, stringent regulations are made for permissible CO levels in the exhaust of 2 and 4-stroke spark ignition engines. The formation of unburnt hydrocarbon is due to incomplete combustion. The two important reasons for incomplete combustion of the fuel are cool metal surfaces of the combustion chamber and imperfect mixture ratio. Of many methods available for reduction of CO/UBHC emissions, the one employing

a catalytic converter [5] is more effective. The use of platinum group metals as catalysts is quite expensive and hence efforts are on for search of cheaper catalysts [5–7]. Further modification of engine design [8–10] and fuel composition [11, 12] are also found to be advantageous in controlling the pollutants in the exhaust of the engine. The use of catalysts to promote combustion is an old concept. More recently, copper is coated over piston crown and inside of cylinder head wall [8–10] and it is reported that the catalyst improves the fuel economy and increased combustion stabilization. In the context of depletion of fossil fuels due to increase of fuel consumption, the search for alternate and renewable fuels has also become pertinent. Ethanol is found to be a better alternate fuel for spark ignition engine compared to methanol as its calorific value is higher than methanol. And also the properties of ethanol are very close to those of gasoline [13]. Alcohol-gasoline blends have been tried [11, 12] to use in conventional spark ignition engine by many researchers. In addition, no major modification in the engine is required if low quantities of ethanol are blended

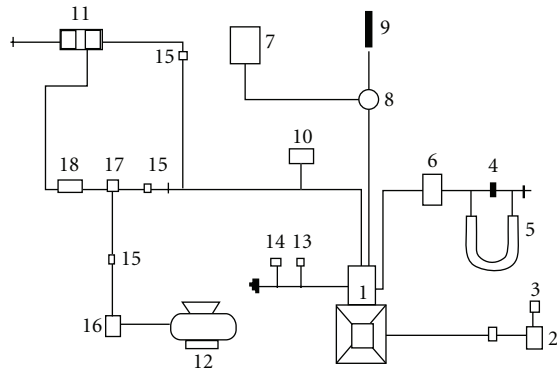

1. Engine
2. Eddy current dynamometer
3. Loading arrangement
4. Orifice meter
5. U-tube water manometer
6. Air box
7. Fuel tank
8. Three-way valve
9. Burette
10. Exhaust gas temperature indicator
11. CO analyzer
12. Air compressor
13. Outlet jacket water temperature indicator
14. Outlet-jacket water flow meter
15. Directional valve
16. Rotometer
17. Air chamber
18. Catalyst chamber

FIGURE 1: Experimental setup.

with gasoline in spark ignition engine. In the present study, the effect of various engine parameters on the control of CO/UHC is reported with different versions of the engine such as conventional engine and copper coated engine with catalytic converter with sponge iron as catalyst and gasohol (ethanol blended gasoline, 20% V/V) as fuel.

## 2. Materials and Methods

The experimental setup employed in the present study is shown in Figure 1. A four-stroke, single-cylinder, water-cooled, spark ignition engine of brake power 2.2 kW at rated speed of 3000 rpm is used. The engine is coupled to an eddy current dynamometer for measuring its brake power. The compression ratio of the engine is varied from 3 to 9 with the change of the clearance volume by adjustment of cylinder head, threaded to the cylinder of the engine. The engine speeds are varied from 2200 to 3000 rpm. In the present investigations, in reducing CO/UHC emissions, the piston crown and inside surface of the cylinder head are coated [7] with copper by plasma spraying. A bond coating of Ni-Co-Cr alloy is applied for a thickness of about 100 microns using a 80 kW METCO plasma spray gun. Over the bond coating copper 89.5%, aluminium 9.5% and iron 1.0% is coated for 300 microns thickness. The coating had very high bond strength and does not wear off

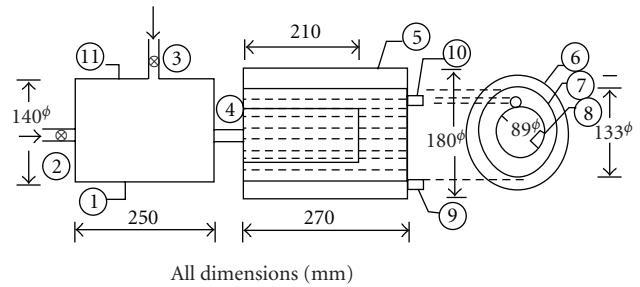

1. Air chamber
2. Inlet for air chamber from the engine
3. Inlet for air chamber from the compressor
4. Outlet for air chamber
5. Catalytic chamber
6. Outer cylinder
7. Intermediate-cylinder
8. Inner-cylinder
9. Outlet for exhaust gases
10. Provision to deposit the catalyst
11. Insulation

FIGURE 2: Details of catalytic converter.

even after 50 hrs of operation. A catalytic converter shown in Figure 2 is fitted to the exhaust pipe of the engine. Provision is made to inject a definite quantity of air into the catalytic converter. The converter is filled with sponge iron catalyst with varying void ratios (where void ratio is the ratio between the volume occupied by the catalyst to the volume of the catalytic chamber) ranging from 0.1 to 1. CO/UHC emissions in the exhaust of the engine are measured with Netel Chromatograph analyzer. Various sets of the exhaust gases are drawn at three different locations: (1) immediately after the exhaust valve of the engine, (2) after the catalytic converter, and (3) at the outlet after air injection into the catalytic converter. The quantity of air drawn from the compressor and injected into the converter is kept constant so that the backpressure does not increase and reverse flow not created in the converter. Experiments are carried out on different configurations of the engine like conventional engine and copper-coated engine with different test fuels like pure gasoline and gasohol under different sets like set-A-without catalytic converter and without air injection, set-B-with catalytic converter and without air injection and set-C with catalytic converter and with air injection.

## 3. Results

The variation of CO emissions in the exhaust of the engine at the peak load operation of the engine at a speed of 3000 rpm with a compression ratio of 9:1 with varying void ratio of the catalyst for different configurations of the engine with different test fuels is shown in Figure 3.

The variation of CO emissions with amount of injected air at peak load operation for gasohol and gasoline at a speed of 3000 rpm with different versions of the engine at a compression ratio of 9:1 is shown in Figure 4.

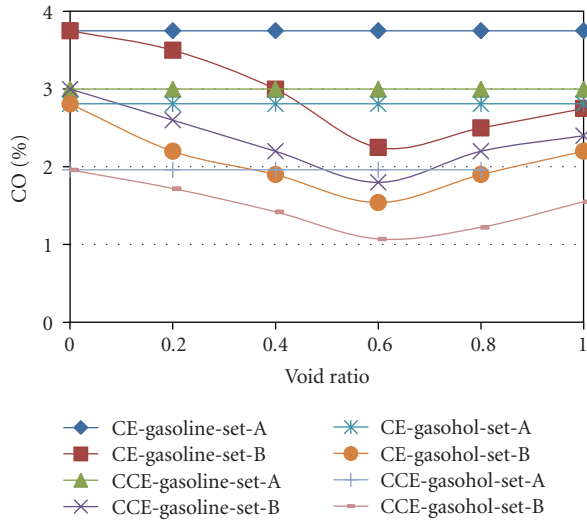

CE-conventional engine, CCE-copper coated engine, load-peak load, speed-3000 rpm, compression ratio-9 : 1, set-A-without catalytic converter and without air injection, set-B-with catalytic converter and without air injection

FIGURE 3: Variation of CO emissions with void ratio of the catalyst for different configurations of the engine with different test fuels.

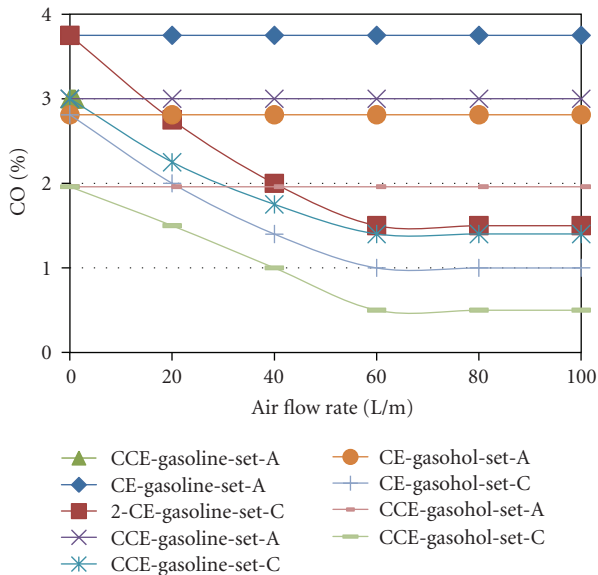

CE-conventional engine, CCE-copper coated engine, set-A-without catalytic converter and without air injection, set-C-with catalytic converter and with air injection, load-peak load, speed- 3000 rpm, Compression ratio-9 : 1, void ratio-0.7 : 1

FIGURE 4: Variation of CO with amount of injected air for different configurations of the engine with different test fuels.

Figure 5 shows the variation of CO emissions with temperature of injected air at peak load at compression ratio of 9:1 and speed of 3000 rpm for different test fuels of gasoline, gasohol with different versions of the engine at different operating conditions of the catalytic converter.

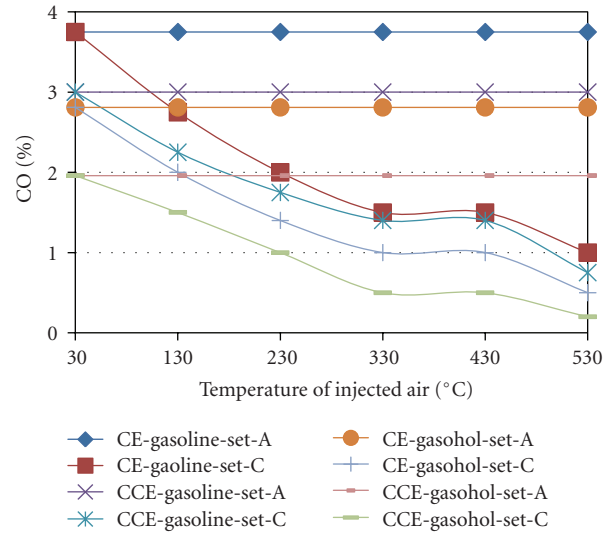

CE-conventional engine, CCE-copper coated engine, set-A-without catalytic converter and without air injection, set-C-with catalytic converter and with air injection, load-peak load, speed- 3000 rpm, compression ratio-9 : 1, void ratio-0.7 : 1

FIGURE 5: Variation of CO with temperature of injected air for different configurations of the engine with different test fuels.

Figure 6 shows the variation of CO emissions in the exhaust with speed of the engine at peak load operation with a compression ratio of 9:1 and at a void ratio of 0.7 for different configurations of the engine with different test fuels.

Figure 7 shows the variation of CO emissions in the exhaust with brake mean effective pressure of the engine at a speed of 3000 rpm with compression ratio of 9:1 and at a void ratio of 0.7 with different test fuels with different versions of the engine under different operating conditions.

Figure 8 shows the bar charts showing the variation of CO emissions at peak load at different compression ratios.

The data of UHC emissions at peak load for different test fuels at different compression ratios and speeds with different versions of the engine is shown in Table 1.

#### 4. Discussion

From Figure 3, it can be observed that the CO emissions reduced considerably with increasing void ratio for both sets. However, beyond the void ratio of 0.7, CO reduction is less due to decrease of surface/volume ratio and increase of backpressure on the engine. At the void ratio 0.7, CO emissions are lower with gasohol when compared to pure gasoline operation, as fuel-cracking reactions are eliminated with ethanol. The combustion of alcohol produces more water vapor than free carbon atoms as ethanol has lower C/H ratio of 0.33 (where C and H represent the number of carbon and hydrogen atoms, resp., in the composition of the fuel) against 0.44 of gasoline. Ethanol has oxygen in its structure, and hence its blends have lower stoichiometric air requirements compared to gasoline. Therefore, more

TABLE 1: Data of unburnt hydro carbon emissions (UHC) in ppm at peak load at various speeds and compression ratios with different test fuels.

Fuels →		Gasoline				Gasohol			
Engine version →		CE		CCE		CE		CCE	
Speed rpm →		2800	3000	2800	3000	2800	3000	2800	3000
Set-A	8 : 1	510	450	375	325	325	300	195	178
	9 : 1	560	500	420	375	375	350	245	228
Set-B	8 : 1	300	250	215	155	170	125	105	90
	9 : 1	350	300	265	206	210	165	145	130
Set-C	8 : 1	200	150	165	80	120	102	80	60
	9 : 1	250	200	152	105	140	122	100	80

Set-A-without catalytic converter and without air injection; Set-B-with catalytic converter and without air injection; Set-C-with catalytic converter and with air injection; C.R: compression ratio; CE: conventional engine, CCE: copper coated engine, Gasohol: 20% of ethanol blended with gasoline by volume.

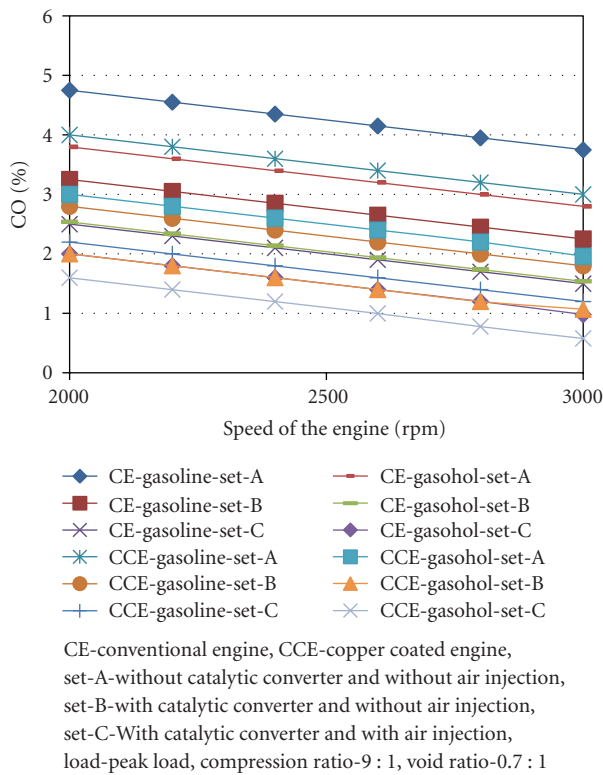

FIGURE 6: Variation of CO with speed of the engine for the different configurations of the engine with different test fuels under different operating conditions of the catalytic converter.

oxygen is available for combustion with the gasohol, which leads to reduction of CO emissions. Ethanol dissociates in the combustion chamber of the engine forming hydrogen, which helps the fuel-air mixture to burn quickly and thus increases combustion velocity, which brings about complete combustion of carbon present in the fuel to carbon dioxide and also carbon monoxide to carbon dioxide and thus makes leaner mixture more combustible, causing reduction of CO emissions.

From Figure 4, it can be observed that percentage of CO emissions is found to be lower when injected air quantity is 60 L/min for conventional engine and copper-coated

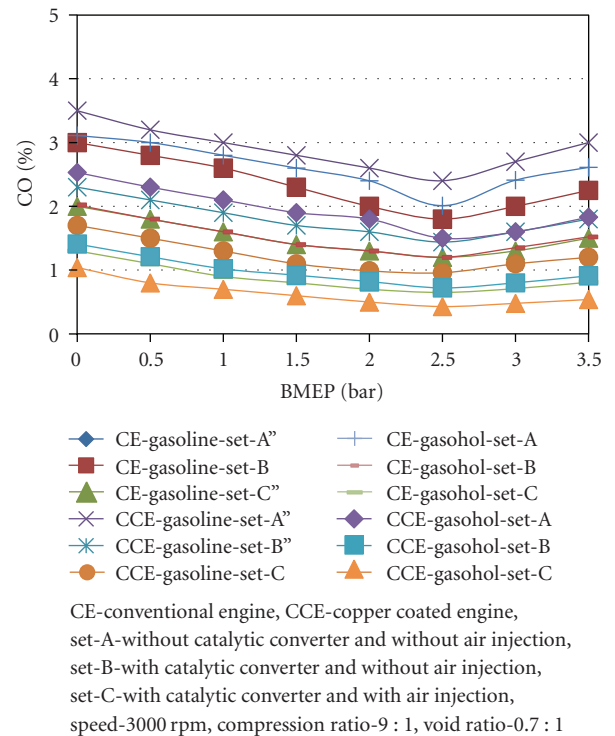

FIGURE 7: Variation of CO emissions with brake mean effective pressure for different configurations of the engine with different test fuels under different operating conditions of the catalytic converter.

engine with gasoline while it is 40 L/min for copper-coated engine with gasohol operation. Excessive airflow rate has low residence time, while lower airflow rate is not sufficient for oxidation reaction to convert CO to carbon dioxide. Thus gasohol requires lower quantity of air in copper-coated engine when compared to pure gasoline operation on conventional engine.

From Figure 5, it can be observed that as temperature of injected air increased, CO emissions are observed to be low for both test fuels with different configurations of the engine. When temperature of the injected air is 310°C, CO emissions are recorded at lower levels with gasoline operation

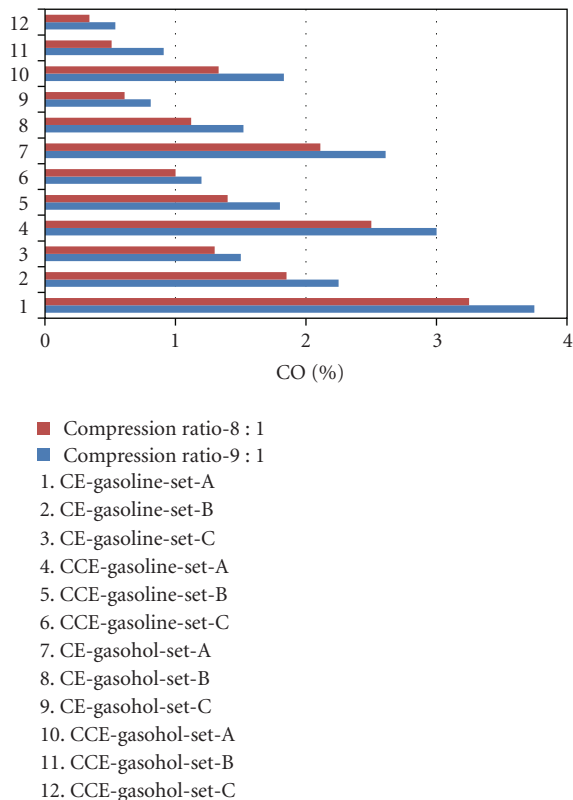

FIGURE 8: Bar chart showing the variation of CO emissions at peak load at different compression ratios at speed of 3000 rpm and void ratio of 0.7: 1.

on conventional engine, while it is 330°C with gasoline operation on catalytic coated engine. This is due to lower exhaust gas temperature with copper-coated engine, with which temperature needed to promote oxidation reaction is higher when compared to conventional engine. Gasohol operation needed injected air at 360°C with both versions of the engine, as gasohol operation decreased exhaust gas temperatures considerably.

From Figure 6, it can be observed that reduction in CO emissions is found to increase with the speed of the engine for all configurations with different test fuels. Improved combustion with the increase of turbulence reduced CO emissions. It is observed that at each speed, the CO content in the exhaust decreased considerably with the use of catalyst, which is more pronounced with the air injection into the converter. Gasohol decreased CO emissions considerably when compared to pure gasoline. Copper-coated engine reduced CO emissions when compared to conventional engine. Catalytic activity increases with temperature as combustion temperature increases with the increase of the speed of the engine. Hence, there is reduction of CO emissions with copper-coated engine when compared to conventional engine.

From Figure 7, it is noticed that CO emissions are observed to increase at part load and full load but decrease at middle load for all sets, as observed by others [9] with both test fuels. At the same time, sufficiently large reduction

of CO has been achieved with the use of catalytic converter. An air injection into the catalytic converter has further decreased the CO emissions in the exhaust at all loads with all the sets. Gasohol reduced CO emissions considerably when compared to pure gasoline operation. Copper-coated engine reduced CO emissions at all loads when compared to other situations.

From Figure 8, it can be noticed that as compression ratio decreased from 9:1 to 8:1, CO emissions decreased with different test fuels with both versions of the engine. This is due [13] to increase of exhaust gas temperature with the decrease of compression ratio leading to oxidation of CO in the exhaust manifold with different versions of the engine.

The trend exhibited by unburnt hydrocarbon emissions (UHC) is similar to that of CO emissions. From the Table 1, it can be noticed that as speed decreased from 3000 rpm to 2800 rpm, the turbulence of combustion decreased, and hence speed of the flame decreases. The gas layer is entrapped between the piston and combustion chamber walls leading to increase in quench area. The presence of quench area inhibits the spreading of the flame, thereby increasing the hydrocarbon emissions.

## 5. Conclusions

A void ratio of 0.7 is found to be the optimum for different test fuels with different versions of the engine. CO/UHC emissions at peak load decreased by 20%–45% with the change of the engine configuration from conventional version to catalytic-coated engine with test fuels. Pollutants decreased by 25–45% with the change of fuel from gasoline to gasohol in both versions of the engine under different operating conditions of the catalytic converter. Pollutants increased by 10%–13% with the change of compression ratio from 8:1 to 9:1 while they decreased by 3%–12% with the change of speed from 2800 rpm to 3000 rpm with different test fuels in both configurations of the engine under different operating conditions of the catalytic converter. Air injection decreased the emissions by 60% with different test fuels with different configurations of the engine.

## Acknowledgements

The authors are thankful to the authorities of Chaitanya Bharathi Institute of Technology, Hyderabad for the facilities provided. The financial assistance provided by Andhra Pradesh Council of Science and Technology (APCOST) for this project is greatly acknowledged.

## References

- [1] S. M. Khopkar, *Environmental Pollution Analysis*, New Age International, New Delhi, INDIA, 2011.
- [2] M. H. Fulekar, "Chemical pollution—a threat to human life," *Indian Journal of Environmental Protection*, vol. 1, no. 3, pp. 353–359, 1999.
- [3] B. K. Sharma, *Engineering Chemistry*, Pragathi Prakashan, Meerut, India, 2008.
- [4] T. Usha Madhuri, T. Srinivas, and K. Ramakrishna, "A study on automobile exhaust pollution with regard to carbon

- monoxide emissions,” *Nature Environment and Pollution Technology*, vol. 2, no. 4, pp. 473–474, 2004.
- [5] K. Kishor, M. V. S. Murali Krishna, A. V. S. S. K. S. Gupta, S. Narasimha Kumar, and D. N. Reddy, “Emissions from copper coated spark ignition engine with methanol blended gasoline with catalytic converter,” *Indian Journal of Environmental Protection*, vol. 30, no. 3, pp. 177–183, 2010.
- [6] M. F. Luo, X. M. Zheng, and Y. J. Zhong, “CO oxidation activity and TPR characterization of  $CeO_2$ -supported manganese oxide catalysts,” *Indian Journal of Chemistry*, vol. 38, no. 7, pp. 703–707, 1999.
- [7] M. V. S. Murali Krishna, C. M. Vara Prasad, and C. h. Venkata Ramana Reddy, “Studies on control of carbonmonoxide emission in spark ignition engine using catalytic converter,” *Ecology, Environment and Conservation*, vol. 6, no. 4, pp. 377–380, 2000.
- [8] R. Manivel and S. Dhandapani, “Experimental investigation of catalytically activated two-stroke spark ignited engine combustion chamber,” in *Proceedings of the 16th National Conference on I.C.Engines and Combustion*, pp. 224–229, January 2000.
- [9] N. Nedunchezian and S. Dhandapani, “Experimental investigation of cyclic variation of combustion parameters in a catalytically activated two-stroke SI engine combustion chamber,” *Engineering Today*, vol. 2, pp. 11–18, 2000.
- [10] M. V. S. Murali Krishna and K. Kishor, “Investigations on catalytic coated spark ignition engine with methanol blended gasoline with catalytic converter,” *Indian Journal (CSIR) of Scientific and Industrial Research*, vol. 67, pp. 543–548, 2008.
- [11] M. V. S. Murali Krishna, K. Kishor, A. V. S. S. K. S. Gupta, D. N. Reddy, and S. Narasimha Kumar, “Emission characteristics of high speed spark ignition engine with catalytic converter,” *Journal of Ultra Scientist of Physical Sciences*, vol. 23, no. 3, pp. 607–612, 2009.
- [12] M. V. S. Murali Krishna, K. Kishor, A. V. S. S. K. S. Gupta, S. N. Kumar, and D. N. Reddy, “Control of pollutants from copper coated spark ignition engine with gasohol,” *Pollution Research*, vol. 29, no. 3, pp. 391–395, 2010.
- [13] A. V. Domkundwar, *A course in Internal Combustion Engines*, Dhanapat Rai & Co, New Delhi, India, 2010.



**Hindawi**

Submit your manuscripts at  
<http://www.hindawi.com>

