

Research Article

Study on Double-Layer Stereo Ecological Cultivation Technology of Greenhouse Gardening Fruit Trees

Gang Chen ¹ and Rajasekhar Boddu ²

¹*Agronomy College of Jilin Agricultural Science and Technology University, Jilin 132101, China*

²*Department of Software Engineering, College of Computing and Informatics, Haramaya University, Dire Dawa, Ethiopia*

Correspondence should be addressed to Gang Chen; chengang2999@126.com and Rajasekhar Boddu; rajsekhar.boddu@haramaya.edu.et

Received 20 January 2022; Revised 12 February 2022; Accepted 23 February 2022; Published 22 March 2022

Academic Editor: Rana Muhammad Aadil

Copyright © 2022 Gang Chen and Rajasekhar Boddu. This is an open access article distributed under the Creative Commons Attribution License, which permits unrestricted use, distribution, and reproduction in any medium, provided the original work is properly cited.

Global food demand can be met by agricultural technology. But the increase in demand also needs effective planting and sufficient illumination in order for crops to grow. In order to solve the problems of low planting efficiency and insufficient illumination in traditional greenhouse horticultural fruit tree planting, we propose a three-dimensional double-layer ecological cultivation technology for greenhouse horticultural fruit trees. The design is a double-layered three-dimensional cultivation model. After the growth rate of horticultural fruit trees is determined, the optimal distance between the two-dimensional cultivation layers is determined by weighted Euclidean distance, and the double-layer three-dimensional ecological cultivation mode of greenhouse horticultural fruit trees is designed. Through the analysis of the irradiance of the double bed planting mode, the design of the light environment in horticultural fruit tree planting is completed. A principal component analysis was used to determine the amount of soil components in double-layer three-dimensional ecological cultivation of greenhouse horticultural fruit trees, and the technology of double-layer three-dimensional ecological cultivation was developed. The results show that the planting efficiency of horticultural fruit trees planted by the technology is always higher than 90%, and the illumination in the planting environment is sufficient.

1. Introduction

The increasing contradiction between man and land, the decrease of arable land, pollution, destruction of land resources, the serious shortage of water resources, the low efficiency of water production, and the low utilization rate of fertilizer have become the important factors restricting the sustainable development of agriculture in China. As a result, the planting area of fruit trees is decreasing, and facility cultivation has become a key method for growing fruit trees in recent years [1]. It is for this reason that facility cultivation is one of the important signs of agricultural modernization in seasons or areas that are not conducive to growing fruit trees and other crops [2, 3]. It is done by artificially designing and controlling the facilities and environment in order to meet the needs of fruit trees and to produce products of high

quality for the people [4, 5]. Application of water and fertilizer integration in fruit tree cultivation is more conducive to controlling temperature and humidity in facilities, optimizing water fertilization, controlling diseases and insect pests, improving the soil microbial environment, improving work efficiency, and resulting in high quality and yielding fruit trees [6, 7]. In recent years, with the increase of facility cultivation in China, the obstacles associated with soil continuous cropping, as well as soil salinization, have intensified due to excessive emphasis on high yields, multiple species, flood irrigation, and excessive fertilization [8–10]. Therefore, designing a new ecological cultivation technology for fruit trees has become a hot topic in current research [11, 12].

In reference [2], a new type of steel-structured solar greenhouse suitable for off-season cultivation of fruit trees

was proposed. Planting fruit trees in this environment can improve the survival efficiency and quality of fruit trees. Based on the new greenhouse structure of “two coverings and three films” and “one covering and two films,” this method is innovated. After three years of research, the steel structure solar greenhouse is summarized. The greenhouse has a high ridge, a large span, increased internal space, and is more suitable for off-season cultivation of fruit trees. At the same time, the greenhouse has strong resistance to natural disasters such as strong wind, snow pressure, and long life. The results showed that the peach in the greenhouse grew well, and the fruit coloring stage and ripening stage were basically the same or earlier than those in the greenhouse structure of “two coverings and three films.” The quality of fruit trees cultivated in this environment is good, and the designed greenhouse environment is suitable for the growth of fruit trees. Nevertheless, planting horticultural fruit trees in this environment has not been successful, and there are still many shortcomings in the quality, quantity, and shape of fruit trees.

The paper [4] puts forward a new facility for strawberry stereoscopic cultivation mode. In order to improve the land-use efficiency of facility strawberries, a new three-dimensional cultivation mode of facility strawberries was designed. A Hongyan strawberry was used as the experimental material. The light conditions, plant nutrition growth, fruit yield and quality, economic benefits, and other indicators of new H-type and traditional cultivation modes were analyzed and compared. Also, the actual production performance of the new H-type three-dimensional cultivation mode was comprehensively evaluated. The results showed that the number of plants, input, yield, total income, and net profit of the new H-type three-dimensional cultivation mode increased by 20%, 44.455%, 20.240%, 35.269%, and 25.876%, respectively. It was preliminarily confirmed that the overall performance of the new H-type three-dimensional cultivation mode was better than that of the traditional cultivation mode. It improves the efficiency of land use. Similar methods have been applied to horticultural fruit tree planting, which can also improve the planting efficiency of fruit trees, but there are still better techniques to be explored [13, 14].

The effect of microridge mulching on soil moisture in the root zone of dwarf horticultural fruit trees was analyzed in literature [15]. This method is mainly used to study the effect of root zone soil on the growth length of dwarf horticultural fruit trees. In this method, three treatments (microridge mulching, straw mulching, and clear tillage) were set up to analyze the changes in soil water storage, orchard water consumption, fruit yield, and water use efficiency of apple trees under different precipitation years. The average soil water storage of 0–300 cm of soil layer in horticultural fields with micro ridges increased by 6.88%, 8.02%, 1.64%, and 2.92%, respectively compared to clear tillage and straw mulching treatment. This significantly improved the soil water storage and water supply capacity of the main root distribution layer of fruit trees and improved the regulation and storage of deep soil water. The effect of microridge mulching on deep soil water storage is better than straw

mulching, and its effect on the balance of soil water storage is closely related to the precipitation in the middle and later stages of fruit tree growth and development. Furthermore, compared with clear tillage, fruit tree transpiration water consumption increased by 16.57% and 12.09%, and evaporation and transpiration did not differ significantly from straw. A microridge mulching system increased yield and water use efficiency significantly in an underwater year and a normal water year, respectively, but there was no difference in fruit yield and water use efficiency when compared to straw. Microridge mulching in horticultural fields can be used as an effective water storage and moisture conservation technology in dwarf apple cultivation systems in Weibei dryland. This technology improves the growth quality of horticultural fruit trees, but the planting area is limited, which leads to some restrictions on the yield of horticultural fruit trees.

The paper [16] describes a system that is based on Arduino and automatically monitors the physical conditions of a greenhouse and controls or regulates them as needed. The system measures the humidity, temperature, soil moisture, etc., of the greenhouse and controls or regulates them accordingly. The greenhouse gardening industry is rapidly expanding, so the use of this automatic control system could be very useful for farmers. This will result in improved productivity and quality of crops. In paper [6], authors have proposed a new feature selection technique called modified recursive feature elimination (MRFE) for selecting appropriate features from a data set for crop prediction. By using a ranking method, the proposed MRFE technique selects and ranks salient features. The results demonstrate that the MRFE method selects the best features while the bagging technique helps determine an accurate crop prediction. The proposed work [17] describes an autonomous style of gardening, which operates autonomously with the assistance of autonomous robots. The robots use sensors to monitor the plants and maintain a database of such information. In this study [18], using artificial neural networks, sensitivity analysis is applied to predict greenhouse tomato yield and determine the most influencing factors for tomato production. Data was collected using a face-to-face survey of 25 greenhouse tomato farms in Biskra Province, Algeria. Despite the high energy inputs, the energy ratio of 1.055 indicates low energy efficiency. As cities grow denser [19], urban planners understand the importance of encouraging and promoting climate and environment-friendly urban areas. Ensuring adequate and easily accessible green public spaces can help shape a healthy urban environment. This study examines how heritage combined with urban gardening can serve to revitalize areas that need it the most. In areas in need of regeneration, heritage combined with urban agriculture is an effective method.

On the basis of the above planting technology, this paper proposes to design a double-layer three-dimensional ecological cultivation technology for greenhouse horticultural fruit trees. As part of the development of a double-layer three-dimensional ecological cultivation model for greenhouse horticultural fruit trees, this paper proposes a bed-type double-layer three-dimensional cultivation model. First

of all, the double-layer three-dimensional cultivation mode of greenhouse horticultural fruit trees was designed. After determining the growth rate of horticultural fruit trees, the optimal distance between layers of the double-layer three-dimensional cultivation mode of greenhouse horticultural fruit trees was determined by weighted Euclidean distance. Then, by analyzing the irradiance of the double bed planting mode, the light environment design of horticultural fruit tree planting was completed. To determine the soil component content in greenhouse horticultural fruit tree double-layer three-dimensional ecological cultivation, principal component analysis methods are used. In this study on greenhouse horticultural fruit tree double-layer three-dimensional ecological cultivation, we have used an optical fiber tracking algorithm to assume that the surface elements of a double-layer plantation and maintenance structure for greenhouse horticultural fruit trees are smooth and transparent.

The organization of this paper is as follows:

After determining the growth rate of horticultural fruit trees, the optimal distance between two layers was determined by weighted Euclidean distance, and the double-layer ecological cultivation mode of horticultural fruit trees in a greenhouse was designed. By analyzing the irradiance of the double bed planting mode, the light environment design of horticultural fruit tree planting was completed. With the help of the principal component analysis method to determine the content of soil components in greenhouse horticultural fruit tree double-layer three-dimensional ecological cultivation, the research on greenhouse horticultural fruit tree double-layer three-dimensional ecological cultivation technology was completed. In the last section, experimental analysis and conclusion are added.

2. Proposed Method

2.1. Design of Double-Dimensional Ecological Cultivation Pattern of Greenhouse Horticulture Fruit Tree. In the design of the three-dimensional ecological cultivation mode of fruit tree gardening, spatial three-D cultivation expands the cultivation area and saves certain land. This planting model makes full use of space and provides planting per area. The general principle of the planting mode is that the height of the double-layer stereo ecological cultivation mode bed is determined according to the height of the planting fruit tree, with the middle and upper trees having less light in the lower layer. The planting pattern extends the planting length north and south. The basic model is shown in Figure 1.

In the greenhouse horticultural fruit tree double-layer ecological cultivation mode, horticultural fruit trees were planted in both the upper and lower layers. Since the growth cycle of each fruit tree is different, the growth rate is also different. Therefore, the height of fruit tree growth should be taken into account in double-layer stereoscopic ecological cultivation, and its growth rate can be expressed as follows:

$$H = L \times w \sum p. \quad (1)$$

In the above formula, H represents the height of horticultural fruit trees, L represents the initial height of the horticultural fruit trees, and w represents the growth factor.

After assuming the growth rate of horticultural fruit trees, the optimal space between the lower layer and the upper layer should be considered in the double-layer stereoscopic ecological cultivation model, and the distance between them determines the quality of horticultural fruit tree growth. The Euclidean distance [10] is used to determine the optimal distance between them.

In Euclidean distance calculation, the distance between the upper and lower vectors is expressed in the following equation:

$$\text{dis}(x, y) = \sqrt{\sum_{i=1}^n (x_i - y_i)^2}. \quad (2)$$

In the above formula, $\text{dis}(x, y)$ represents the Euclidean distance, n represents the dimensions, x_i represents the components of a vector in i dimensions, and y_i represents the component of the vector on the i dimension.

In formula (2), it is only the traditional European distance between double layers, and it is impossible to determine whether this distance is the optimal distance between double bed plantings. On this basis, this paper weighted it to obtain the optimal distance [11] in the stereo ecological cultivation mode of greenhouse gardening fruit trees as expressed in the following equation:

$$\text{dis}'(x, y) = \sqrt{\sum_{i=1}^n \left(\frac{T'}{T} k (x_i - y_i)^2 \right)}. \quad (3)$$

In the above formula, (T'/T) represents the weights, k represents the regulator between the bilayers, and value range of [1].

In the design of the double-layer three-dimensional ecological cultivation model of greenhouse horticultural fruit trees, this paper designs a bed-type double-layer three-dimensional cultivation model. After determining the growth rate of horticultural fruit trees, the optimal distance between bed-type double-layer three-dimensional cultivation layers were determined by weighted European distance. The design of the double-layer ecological cultivation model of greenhouse horticultural fruit trees was completed.

2.2. Light Environment Design of Double-Dimensional Ecological Cultivation Pattern of Greenhouse Horticulture Fruit Tree. According to the above design of double-layer three-dimensional ecological planting mode, in order to achieve the realization of this research technology, the temperature environment of fruit trees in the greenhouse is designed. In this design, the planting temperature and humidity in the greenhouse are controlled by the Internet of Things technology and adjusted according to its needs. Due to the horticultural fruit trees's growth process, light demand is very critical [11]. Therefore, in the study of greenhouse environmental temperature, the problem of light in the greenhouse is mainly analyzed. In the greenhouse environment, the greenhouse ground and the inner surface of the envelope exhibit different brightnesses. This is due to the interaction of solar radiation, indoor supplementary

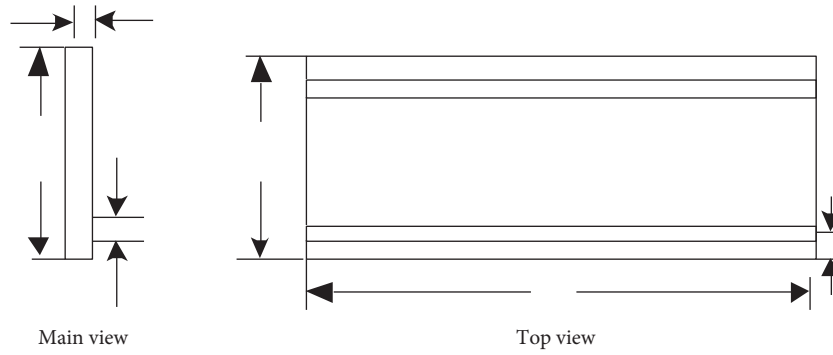

FIGURE 1: Double-dimensional ecological cultivation pattern of greenhouse horticulture fruit trees.

lighting, and the surface of the enclosure. The problem to be solved by the light environment model is how to use the mathematical model to calculate the light radiation energy received at any point in the greenhouse. The brightness of the object surface radiated in a given direction in space can be calculated by the light environment model [12]. In terms of the light energy composition received by the research site, the solar radiation energy can be the light energy transmitted and reflected by the inner surface of the greenhouse envelope (the light supplement lamps directly provide the light energy for the indoor surface). Transmitted light can be divided into direct transmission light and indirect transmission light [13]. Surface reflected light can also be divided into direct and indirect reflected light, which is produced by solar radiation directly incident on a certain surface or repeatedly reflected by other surfaces. Therefore, the greenhouse light environment model can be simply divided into the local light environment model and the overall light environment model. The local light environment model does not consider the mutual reflection and transmission between the surfaces. The overall light environment model reflects the distribution of light energy more completely, and the calculation of the model is much larger than that of the local model. In greenhouse horticulture, fruit tree planting, light is very important [14]. In this study, the light in the greenhouse is regarded as light energy flow, and the angle of light is analyzed according to a certain law of physical conservation so as to determine the angle and duration of light for fruit trees.

It is assumed that the angle of greenhouse horticultural fruit trees exposed to light is a solid cone angle as expressed in the following equation (4):

$$z = \frac{aS}{b^2}. \quad (4)$$

In the above formula, aS represents the light-illuminated corner heart of greenhouse gardening trees and b represents the cross-sectional area on the cone-angle sphere.

The light exposure angle of greenhouse horticultural fruit trees is shown in Figure 2.

According to the angle analysis of the light illumination, the luminous intensity of the greenhouse gardening fruit tree surface in one direction is defined as the light flux in the unit stereo angle in that direction as expressed in the following equation (5):

$$E = \frac{dF}{as}. \quad (5)$$

In the above formula, dF represents luminous flux.

A major problem to be solved in greenhouse gardening and fruit tree planting is the solar radiation intensity acceptable to fruit trees on the greenhouse cultivation bed or on the canopy.

If the vS represents the luminous surface that contributes light energy to the sun, h represents the brightness of the radiation, the incident and stereo angles of the greenhouse horticultural trees are represented as β and ϑ , respectively, and the light flux x of solar radiation can be expressed as in the following equation:

$$dF = h \cos \beta vS \cos \vartheta. \quad (6)$$

Through the calculation of luminous flux, we can clearly understand the radiation illumination that greenhouse horticultural fruit trees can receive. In this paper, the optical fiber tracking algorithm is used to assume that the surface elements of the double-layer planting and maintenance structure of greenhouse horticultural fruit trees are smooth and transparent, and the irradiance distribution of the sun can be expressed as in the following equation:

$$G_m = \begin{cases} \frac{1}{dc_i} & V = R. \\ 0 & \text{others} \end{cases} \quad (7)$$

In the above formula, R represents the solar irradiation light reflection vector. At this point, the ideal rule projection light energy distribution function can be expressed as the following equation:

$$G_t = \begin{cases} \frac{1}{dg_i} & V = R. \\ 0 & \text{others} \end{cases} \quad (8)$$

By analyzing the light irradiance of double bed planting mode, the light environment design of horticultural fruit trees is completed, which lays a foundation for subsequent planting.

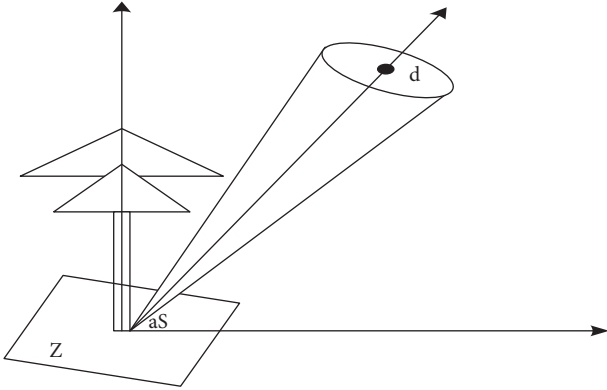

FIGURE 2: Angle of greenhouse gardening fruit trees.

2.3. Design of Three-Dimensional Ecological Cultivation Soil Environment. Soil is an important support for the growth of horticultural fruit trees in double-layer ecological cultivation of greenhouse horticultural fruit trees. This paper examines the soil environment for double-layer ecological cultivation of greenhouse horticultural fruit trees. Firstly, the comprehensive scores of soil nutrients in the upper and lower layers were calculated by principal component analysis. In this process, the soil nutrient data should be standardized to avoid the analysis of different nutrient levels affecting the soil environment of fruit tree planting. The conversion of soil nutrients to standard data is given by the following equation:

$$Y_i = \frac{y_a - y_b}{y} \quad (9)$$

In the above formula, Y_i represents the standardized values for greenhouse gardening, y_a represents the initial soil nutrient index for the cultivation of greenhouse horticultural fruit trees y_b , on behalf of the greenhouse horticultural fruit tree planting soil nutrient initial index average, and y represents the initial standard deviation.

In the design of the double-layer ecological cultivation soil environment of greenhouse horticultural fruit trees, the higher the comprehensive score, the higher the nutrient content, and the higher the soil fertility degree [10, 18]. Therefore, according to the eigenvalue and eigenvector of the relationship matrix calculated by the standard deviation matrix of the double-layer ecological cultivation soil of greenhouse horticultural fruit trees, the fertility of the soil is determined by the following equation:

$$f_m^2 = \frac{1}{n-1} \sum_{i=1}^n (y_a - y_b)^2 \quad (10)$$

In the above formula, f_m^2 represents the fertility of the soil.

The results of the above calculation are shown in Table 1.

In the principal component analysis of chemical components in the soil environment of double-layer ecological cultivation of greenhouse horticultural fruit trees, the eigenvalue of each principal component can represent the amount of original information of the corresponding components described as shown in Figure 3.

In Figure 3, the cumulative contribution rate of the first two principal components is high, so the extraction of the first two principal components can generalize most of the information. That is, the first two principal components can be used as a summary of soil nutrient characteristics. The soil organic matter, total nitrogen, and available phosphorus in the soil held a high load on the first principal component; that is, the correlation with the first principal component was strong. Also, organic matter had a significant correlation with total nitrogen and available phosphorus, indicating that organic matter is a major carrier of total nitrogen and available phosphorus in soil.

3. Results and Analysis

3.1. Experimental Scheme Design. In order to verify the effectiveness of the proposed technology, an experimental analysis was carried out. According to this method, the two-layer planting pattern of horticultural planting is designed to plant low horticultural fruit trees to watch apple trees and ornamental orange trees. The growth period of the fruit tree is 3 months, and the height is about 50 cm. In this space, 50 low apple trees and 50 ornamental orange trees are planted in the upper layer. It was observed for 3 months and the final experimental results were analyzed. The same way is planted with literature [2] methods and literature [15], and then the effectiveness of the three methods is compared.

3.2. Experimental Index Design. To verify the effectiveness of this method, we compared [2] and [15] techniques. The results of the planting efficiency of the gardening trees and the illumination of plantings are described in this section.

3.3. Analysis of Experimental Results

3.3.1. Analysis of Planting Efficiency of Horticultural Fruit Trees with Different Methods. To verify the effectiveness of the proposed technique, the experimental analysis is compared with the literature [2] technique and the literature [15] technique. The purpose of this comparative study is to analyze the efficiency of sample horticultural fruit tree plantings. In this experiment, the planting efficiency is compared with the survival rate of horticultural fruit trees after planting. The results are shown in Table 2.

It is estimated that more than 90% of plants will have survived after planting technology, about 85% of plants will survive after planting technology, and about 86% of plants will survive after planting technology. In contrast, the survival rate of trees planted by the [15] technique is higher, which is due to the composition of the double planting environment and soil environment, which improves the survival rate of horticultural fruit trees.

In order to demonstrate the high efficiency of horticultural fruit trees, in this paper, the plot area used for the cultivation of sample fruit trees by three methods is analyzed experimentally to ensure the survival rate. The results are shown in Table 3.

TABLE 1: Specific environment of greenhouse gardening fruit trees.

	Organic matter (g kg ⁻¹)	Total nitrogen (g kg ⁻¹)	Rapidly available phosphorus (mg kg ⁻¹)	Available potassium (mg kg ⁻¹)
Organic matter/g kg ⁻¹	1.000	0.906	0.606	0.126
Total nitrogen/g kg ⁻¹		1.000	0.541	0.167
Rapidly available phosphorus/mg kg ⁻¹				-0.019
Available potassium/mg kg ⁻¹				1.000

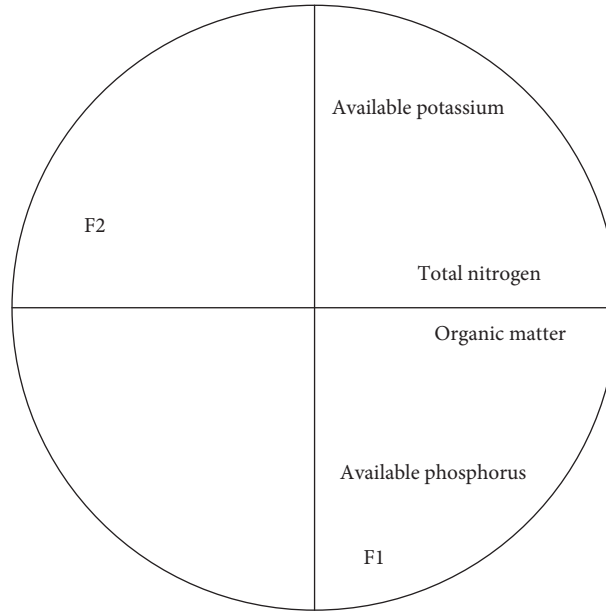

FIGURE 3: Analysis of the main chemical composition of the cultivated soil environment.

TABLE 2: Analysis of fruit yield of sample trees under different planting techniques (%).

Number of planted trees	Methods of this paper	Protemics [2]	Hort technology [15]
10	90	80	80
20	95	80	70
30	96	85	86
40	94	84	70
50	95	82	85

TABLE 3: Analysis of planting area of sample fruit trees under different techniques (m²).

Number of planted trees	Methods of this paper	Hort technology [15]	Protemics [2]
10	5	10	11
20	5	20	22
30	10	30	33
40	10	40	44
50	15	50	55

The data in Table 3 show that with the change of the number of fruit trees planted in the sample, there are some differences in the planting area of fruit trees cultivated by three techniques. Among them, the proposed technology planting area is always lower than the other two existing techniques. This is because the planting method designed in this paper is based on double-layer planting, which saves the land area and verifies the effectiveness of this method.

3.3.2. Analysis of Illumination in Sample Gardening Fruit Trees. The key factors affecting the growth of horticultural fruit trees are illumination. Therefore, the light intensity of plants in the process of planting is analyzed in the experiment. By comparing the ideal temperature change with the actual temperature, the effectiveness of this method is verified. The experimental results are shown in Figure 4.

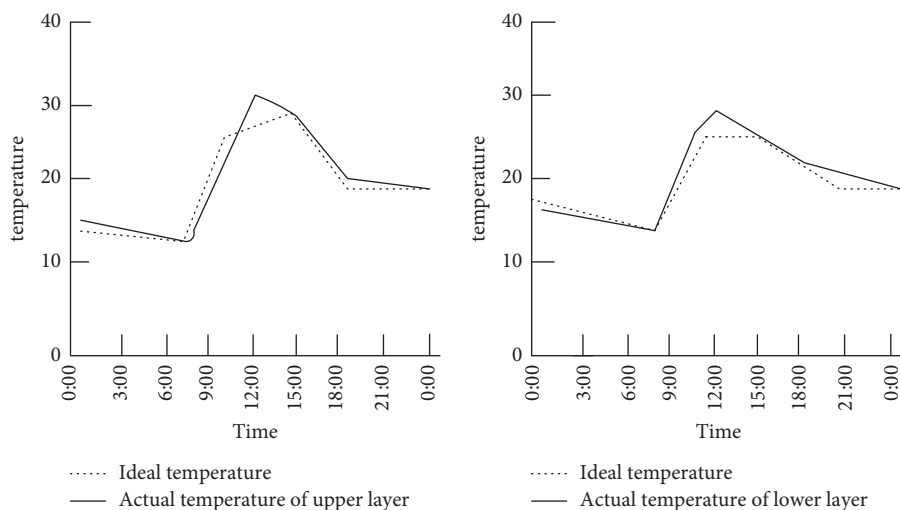

FIGURE 4: Results of light illumination in the planting of horticultural fruit trees.

The experimental results in Figure 4 show that the illumination of horticultural fruit trees varies under different time periods. Among them, the double-layer planting temperature and the ideal temperature are more consistent. When the light is most intense between 9:00 am and 12:00 pm in the upper layer, the temperature increases, but it is also within the tolerance of horticultural plants. However, the change curve is close to the ideal temperature, which verifies the effectiveness of this technique.

4. Conclusion

In order to maximize the efficiency of greenhouse gardening and save planting land, this paper proposes a double-layer ecological cultivation technique for greenhouse horticultural fruit trees. By using weighted European distances, we determined the optimal interlayer distance of double-layer stereoscopic cultivation of greenhouse horticultural fruit trees. We then developed an ecological cultivation model for double layer stereoscopic ecological cultivation of greenhouse horticultural fruit trees. When we compare the proposed method with the traditional method, it was observed that the planting efficiency of horticultural fruit trees planted by the proposed technology is always higher than 90%, and the planting land area is less. Along with that, the horticultural fruit trees planted with the proposed technology have sufficient illumination and are suitable for horticultural fruit trees. In the future, we can increase the layers in the ecological cultivation technique to increase the amount of healthy fruit growth.

Data Availability

All the data used in this article is included within the article itself.

Conflicts of Interest

The authors declare that there are no conflicts of interest regarding the publication of this paper.

Acknowledgments

The authors are thankful to the Jilin higher education association (2017) for carrying out this research work under “Research on the construction of horticultural training base” in applied undergraduate colleges.

References

- [1] L. Yang, F. Gong, E. Xiong, and W. Wang, “Proteomics: a promising tool for research on sex-related differences in dioecious plants,” *Frontiers of Plant Science*, vol. 6, p. 954, 2015.
- [2] L.-H. Gao, M. Qu, H.-Z. Ren, X.-L. Sui, Q.-Y. Chen, and Z.-X. Zhang, “Structure, function, application, and ecological benefit of a single-slope, energy-efficient solar greenhouse in China,” *Hort Technology*, vol. 20, no. 3, pp. 626–631, 2010.
- [3] Y. Y. Huang, S. W. Liu, Y. K. Chen, X. Liu, H. Y. Zheng, and T. Wang, “Construction of water and fertilizer integrated fertilization system for greenhouse substrate cultivation,” *Jiangsu Agricultural Sciences*, vol. 47, no. 12, pp. 278–281, 2019.
- [4] P. Liao, P. Liu, Y. Wang et al., “Stereoscopic cultivation of *Panax notoginseng*: a new approach to overcome the continuous cropping obstacle,” *Industrial Crops and Products*, vol. 126, pp. 38–47, 2018.
- [5] B. Mareschal, M. Kaur, V. Kharat, and S. Sakhare, “Convergence of smart technologies for digital transformation,” *Tehnički Glasnik - Technical Journal*, vol. 15, p. 1, 2021, <https://doi.org/10.31803/tg-20210225102651>.
- [6] G. Mariammal, A. Suruliandi, S. P. Raja, and E. Poongothai, “Prediction of land suitability for crop cultivation based on soil and environmental characteristics using modified recursive feature elimination technique with various classifiers,” *IEEE Transactions on Computational Social Systems*, vol. 8, no. 5, pp. 1132–1142, 2021.
- [7] M. Kaur and S. Kadam, “Bio-inspired workflow scheduling on HPC platforms,” *Tehnički glasnik*, vol. 15, no. 1, pp. 60–68, 2021, <https://doi.org/10.31803/tg-20210204183323>.
- [8] E. Rodríguez-Caballero, Y. Cantón, S. Chamizo, R. Lázaro, and A. Escudero, “Soil loss and runoff in semiarid ecosystems: a complex interaction between biological soil crusts, micro-

- topography, and hydrological drivers,” *Ecosystems*, vol. 16, no. 4, pp. 529–546, 2013.
- [9] P. Sun, R. X. Lin, H. Bao, and J. S. Shen, “Ecological high value stereoscopic cultivation techniques of grape strawberry dendrobium officinale,” *Northern Horticulture*, vol. 14, no. 10, pp. 200–203, 2018.
- [10] P. Y. Wang, P. G. Tian, W. G. Wu, T. T. Cao, and F. Y. Shen, “Study on cultivation techniques of Pitaya in greenhouse in North China,” *Agriculture & Technology*, vol. 41, no. 2, pp. 103–105, 2021.
- [11] V. Jagota, M. Luthra, J. Bholra, A. Sharma, and M. Shabaz, “A secure energy-aware game theory (SEGaT) mechanism for coordination in WSAWs,” *International Journal of Swarm Intelligence Research*, vol. 13, no. 2, pp. 1–16, 2022, <https://doi.org/10.4018/ijisir.287549>.
- [12] K. Y. Yeung and W. L. Ruzzo, “Principal component analysis for clustering gene expression data,” *Bioinformatics*, vol. 17, no. 9, pp. 763–774, 2019.
- [13] H. F. Zhang and H. Zhang, “The extraordinary mode in the three-dimensional magnetized plasma photonic crystals with layer-by-layer lattices containing the function dielectric,” *The European Physical Journal*, vol. D73, no. 7, pp. 1424–1428, 2019.
- [14] Z. Y. Zhang, H. Zhu, Q. Cheng et al., “Low polarization-dependent-loss double-layer grating coupler for three-dimensional photonic integration,” *Optics Communications*, vol. 445, no. 12, pp. 1414–1421, 2019.
- [15] P. Zhou, J. Qian, W. Yuan et al., “Effects of interval flooding stress on physiological characteristics of apple leaves,” *Horticulturae*, vol. 7, no. 10, p. 331, 2021.
- [16] P. Kumar, S. Saroj, S. Kumar, and C. Azad, “Automated monitoring and regulation of user-friendly greenhouse using Arduino,” in *Proceedings of the Fourth International Conference on Microelectronics, Computing and Communication Systems*, pp. 43–59, Singapore, June 2021.
- [17] D. Ruth Anita Shirley, K. Ranjani, G. Arunachalam, and D. A. Janeera, “Automatic distributed gardening system using object recognition and visual servoing,” in *Inventive Communication and Computational Technologies* Springer, Singapore, 2021.
- [18] S. Mikhailova, L. Mikhailov, G. Ismailova, N. Kenes, R. Yersaiyn, and R. Mahmutov, “Solar-powered smart window design with aerosol trap and greenhouse gardening,” *Materials Today Proceedings*, vol. 49, pp. 2527–2531, 2022.
- [19] G. Swensen, V. E. Stafsg, and V. K. Simon Nielsen, “Visionscapes: combining heritage and urban gardening to enhance areas requiring regeneration,” *International Journal of Heritage Studies*, vol. 27, pp. 1–27, 2022.