

Research Article

Development of Detection Equipment for a Polymerase Chain Reaction with a Loop-Mediated Isothermal Amplification Reaction

Wei-Chien Weng  and Yu-Cheng Lin 

Department of Engineering Science, National Cheng Kung University, Tainan, Taiwan

Correspondence should be addressed to Yu-Cheng Lin; yuclin@mail.ncku.edu.tw

Received 6 January 2021; Revised 3 March 2021; Accepted 17 March 2021; Published 30 March 2021

Academic Editor: Sheng-Joue Young

Copyright © 2021 Wei-Chien Weng and Yu-Cheng Lin. This is an open access article distributed under the Creative Commons Attribution License, which permits unrestricted use, distribution, and reproduction in any medium, provided the original work is properly cited.

In this research, low-cost detection equipment intended to carry out a polymerase chain reaction (PCR) through a loop-mediated isothermal amplification (LAMP) reaction is presented. We designed the internal structure with SolidWorks and AutoCAD. The equipment comprised a Raspberry Pi development board, a temperature control module, and a fluorescent optical detection module. The main program, temperature control, fluorescent signal processing, signal analysis, and screen display were programmed with Java. We applied the digital temperature controller module to obtain precise temperature control of the equipment. The experimental results showed that the heating rate of the testing equipment could reach 65°C within 4 minutes and could be accurately controlled to within 1°C. The duration of the LAMP PCR experiment was found to be significantly shorter than that of the conventional PCR. The results also revealed that with LAMP PCR, the temperature could be accurately controlled within a specific range, and the designed heating tasks could be completed within 15 minutes to one hour, depending on the specimen. The equipment could also correctly read both the positive and negative reactions with fluorescent signals. Thus, the proposed LAMP PCR detection equipment is more sensitive, more stable, and more cost-effective than other conventional alternatives and can be used in numerous clinical applications.

1. Introduction

The detection of many infectious diseases including tuberculosis, AIDS, bacterial and viral infections, genetic diseases, foodborne diseases, SARS, MERS, and COVID-19 mostly depends on a specific detection technique—a polymerase chain reaction (PCR). A PCR is a relatively simple, inexpensive tool that can be used to focus on a DNA segment in order to duplicate the specified segment many times [1–4]. Loop-mediated isothermal amplification (LAMP) PCR is a nucleic acid amplification technology developed by Japanese scientist Notomi and his team in 2000 [5, 6]. This DNA amplification method can react at a constant temperature and form a circular loop. Different from the conventional PCR, LAMP PCR does not require multistage temperature control. It only requires a constant temperature environment within a range

of 60–65°C, which can be provided by a water bath or a drying hot plate environment.

Because there are as many as three pairs of primers employed in LAMP PCR, its specificity and sensitivity are higher than ordinary PCRs. Furthermore, the number of molecules can be increased to 1E10 after LAMP PCR is completed and that quantity is even 1E4 times more than the quantity of 1E6 molecules generated by conventional PCR. Moreover, in the amplification process, the enzyme used in LAMP PCR will generate pyrophosphoric acid, which will then combine with magnesium ions and generate a large amount of white precipitate visible to the naked eye. Thus, there is no need to employ agarose gel electrophoresis and UV light to detect and interpret the analyte.

After pure DNA is extracted from an organism, the most common analytical method used to separate and

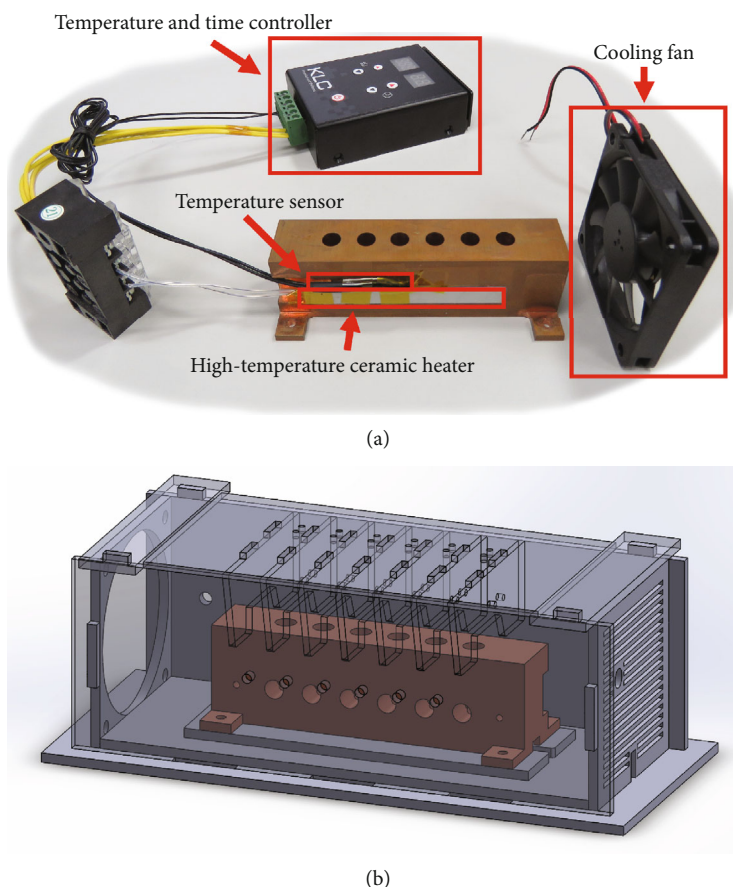

FIGURE 1: Temperature control: (a) exploded photo of the components of the temperature control system and (b) perspective of the combination of the optical detection subsystem, the copper block, and the optical detection dark box.

analyze macromolecules and their fragments based on their size and charge is a gel electrophoresis analysis. There are two types of gel electrophoresis commonly used to analyze DNA: agarose gel electrophoresis (AGE) and polyacrylamide gel electrophoresis (PAGE) [7].

PCR can also be used in many other ways, including for diagnosing diseases, identifying bacteria and viruses [8–12], and matching criminals with crime scenes. However, most PCR detection operations are time consuming, so developing more effective and faster LAMP PCR detection equipment is, thus, essential.

This research is aimed at developing LAMP PCR detection equipment intended to establish the proper temperature conditions for the reaction of detected specimens and to use a precise temperature control technology to shorten the reaction time for conventional PCR. After the reaction is completed, photoresistors are used to detect the fluorescent signals and the results are shown on a screen.

In 2000, Yasuda et al. applied infrared laser beams and noncontact heating methods to the PCR thermal cycle and successfully detected the results of PCR with fluorescence detection [13]. In 2009, Sappat et al. used a light-dependent resistor (LDR) to detect the white precipitate from magnesium pyrophosphate ($Mg_2P_2O_7$) produced by

the reverse transcription loop-mediated isothermal amplification (RT-LAMP) method for the detection of the Taura syndrome virus (TSV) in Thai shrimp [14]. In 2015, Zhou et al. used LAMP PCR for 15 different strains and then used three detection methods to verify them, including SYBR Green I fluorescence detection, colloidal electrophoresis analysis, and turbidity detection. Finally, it was verified that LAMP PCR is simpler, faster, and more sensitive than conventional PCR [15].

In March 2020, due to the SARS-CoV-2 (COVID-19) pandemic, Kashir and Yaqinuddin used LAMP PCR to reduce the cost of coronavirus detection. The results showed the sensitivity using LAMP assay to be 100-fold higher than that of conventional RT-PCR methods [16]. Furthermore, Rödel et al. used reverse transcription-LAMP (RT-LAMP) for rapid diagnosis of the severe acute respiratory syndrome Coronavirus-2 (SARS-CoV-2) because of the ease of operation and the option to bypass RNA extraction. Combining the RT-PCR and RT-LAMP increased the diagnostic sensitivity to 92–100% [17].

2. Materials and Methods

The LAMP PCR detection equipment developed in this work consisted of a Raspberry Pi small single-board

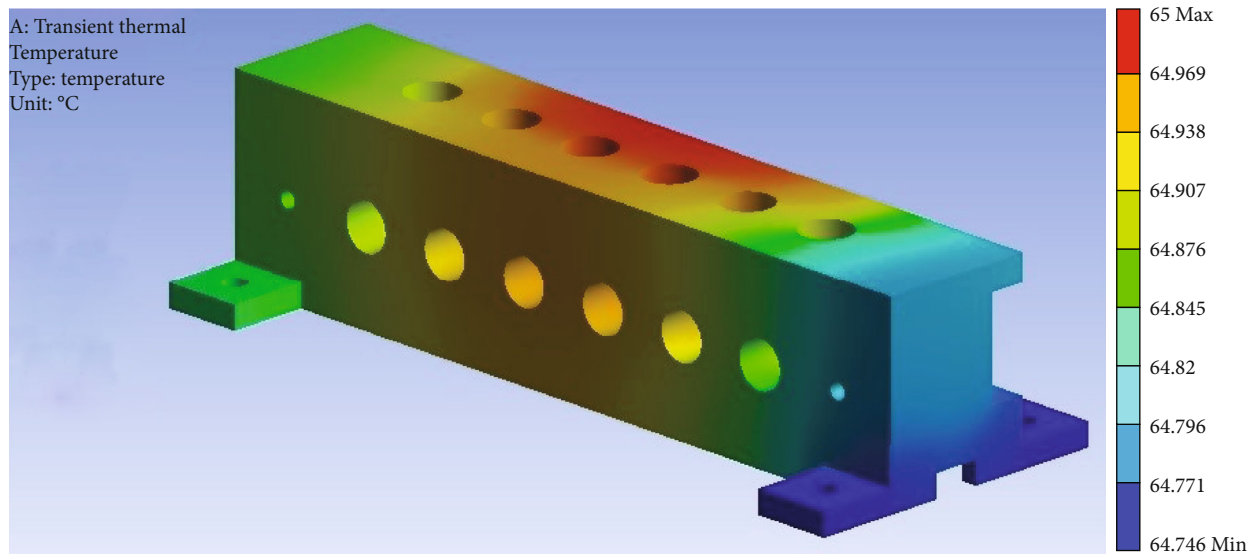

(a)

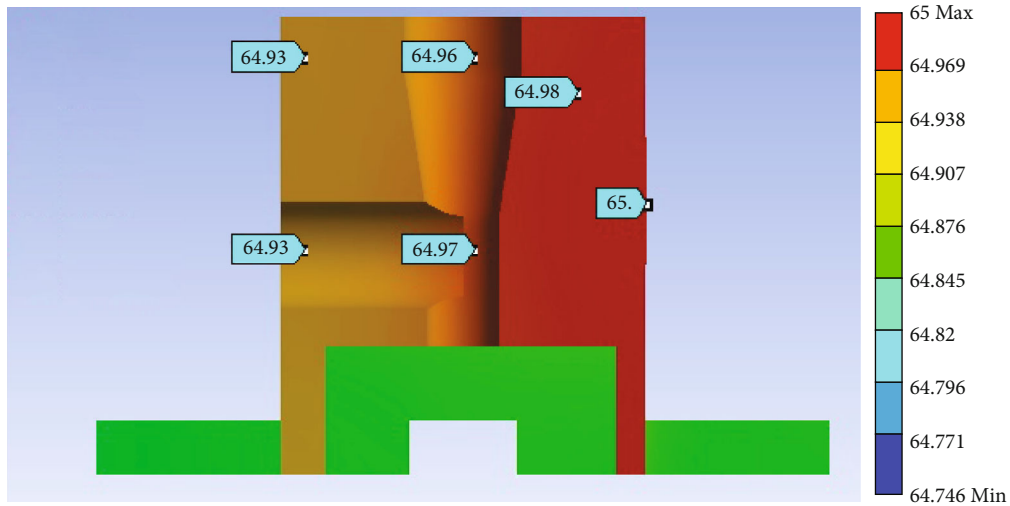

(b)

FIGURE 2: Simulation of the temperature distribution of the metal heating block: (a) overall temperature distribution and (b) a cross-sectional view of the temperature distribution.

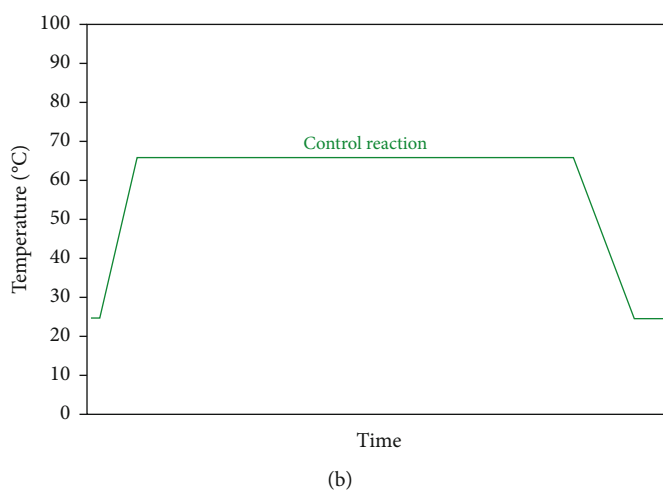
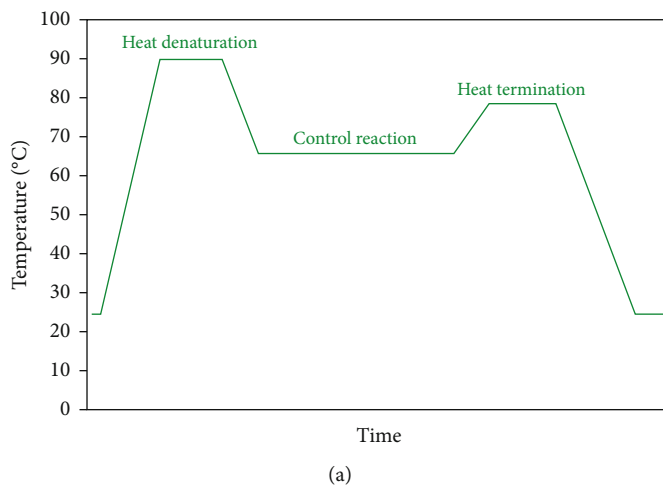

FIGURE 3: Illustration of the differences in heating control between LAMP PCR and traditional PCR, (a) Traditional PCR requires shifting between three temperatures and as many as 25 repeated temperature shift operations. (b) LAMP PCR simply requires fixing at one temperature.

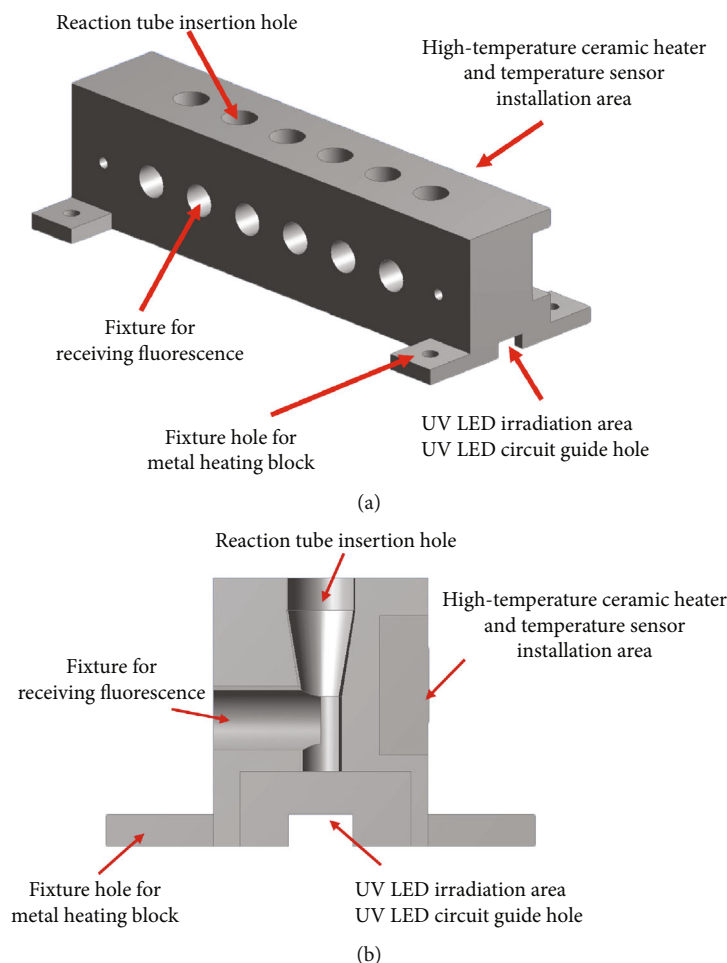

FIGURE 4: Design of the metal heating block: (a) external view of the metal heating block and its compartments and (b) a cross-sectional view of the metal heating block and its compartments.

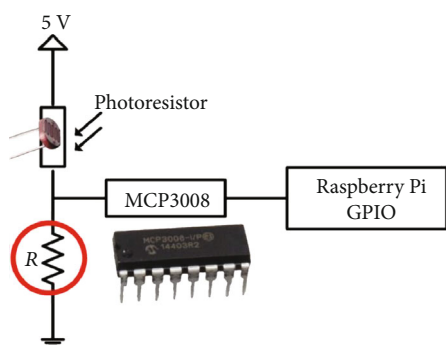

FIGURE 5: The detection circuit with a photoresistor.

computer, a power supply, a temperature controller, and a fluorescent signal detector. The equipment case was designed with SolidWorks and AutoCAD. The total size of the unit, including the temperature control system, the fluorescent signal detecting system, and a copper block, was $18.6\text{ cm} \times 8.0\text{ cm} \times 6.6\text{ cm}$. The temperature control system comprised a thin high-temperature ceramic heater, a temperature sensor, a digital temperature time controller, and a cooling fan, as shown in Figure 1(a). We used a

GCC C180II laser engraver to cut the PMMA plates and then combined the assembled optical detection dark box with the copper block and the temperature control system. The combination is shown in Figure 1(b).

The Raspberry Pi was the core piece of hardware, which was used for the output calculation of the temperature controller to operate the heating, control the photoresistors used to capture the fluorescent signals, analyze the fluorescent signals, and store the results, which were displayed on the screen.

The software used in the LAMP PCR detection equipment, including the main program, the stable temperature control, and the fluorescent signal detection, was programmed with Java. For the LAMP PCR heating system, we used the time and temperature controller to shorten the experimental time and improve the heating efficiency and stability. To enhance the heating efficiency, a high-temperature ceramic heater was used. With the help of a heating device, the copper block could rapidly increase the temperature to the target temperature and keep it constant. The temperature distribution of the metal block was simulated using ANSYS software. Figure 2(a) shows that the overall temperature difference was less than 0.3°C .

TABLE 1: Relationship between the resistance value of resistor R and the voltage of the photoresistor when the photoresistor was not illuminated with UV light.

Resistor R (Ω)	Voltage of the photoresistor (V)			Average (V)	STDEV	CV
	1st	2nd	3rd			
10 k	0.18	0.22	0.23	0.210	0.02160	10.287%
30 k	0.57	0.58	0.69	0.613	0.05437	8.864%
50 k	0.58	0.55	0.67	0.600	0.05099	8.498%
100 k	0.91	0.99	0.93	0.943	0.03399	3.604%
150 k	1.19	1.21	1.27	1.223	0.03399	2.779%
200 k	1.53	1.62	1.49	1.547	0.05437	3.515%
250 k	2.48	2.2	2.25	2.310	0.12193	5.278%
300 k	2.49	2.41	2.55	2.483	0.05735	2.309%

TABLE 2: Relationship between the resistance value of resistor R and the voltage of the photoresistor when the photoresistor was illuminated with UV light.

Resistor R (Ω)	Voltage of the photoresistor (V)			Average (V)	STDEV	CV
	1st	2nd	3rd			
10 k	1.27	1.25	1.24	1.253	0.01247	0.995%
30 k	2.49	2.5	2.54	2.510	0.02160	0.861%
50 k	3.31	3.33	3.35	3.330	0.01633	0.490%
100 k	4.04	4.04	4.05	4.043	0.00471	0.117%
150 k	4.33	4.34	4.34	4.337	0.00471	0.109%
200 k	4.48	4.49	4.49	4.487	0.00471	0.105%
250 k	4.59	4.57	4.59	4.583	0.00943	0.206%
300 k	4.66	4.67	4.67	4.667	0.00471	0.101%

TABLE 3: Results for LAMP PCR heating and the optical detection experiment.

Time (min)	Positive (V)	Negative (V)
0	2.702	3.499
5	2.778	3.570
10	2.755	3.627
15	2.718	3.582
20	2.729	3.550
25	2.843	3.476
30	2.787	3.467
35	2.864	3.432
40	2.882	3.591
45	3.013	3.585
50	3.043	3.529
55	3.015	3.554
60	3.153	3.540

The cross-sectional temperature distribution in Figure 2(b) also shows that the temperature difference between the reaction tube placement area and the high-temperature

ceramic heater was within 0.1°C . Since the temperature in the chamber during LAMP PCR only had to be kept between 60 and 65°C , it was much easier to control the temperature with LAMP PCR than with conventional PCR, which requires adjusting the thermal cycling control more than 25 times to shift between three different temperatures. Therefore, LAMP PCR can greatly reduce the costs of hardware development and production. The differences in the LAMP PCR and conventional PCR heating processes are shown in Figure 3.

For the experiment, we used three chemicals produced by Eiken Chemical Co., Ltd., Japan: a DNA amplification kit, a fluorescent detection reagent, and the DNA control set. In terms of fluorescent signals, we first used 365 nm ultraviolet light-emitting diodes to excite the specimens. The specimens then emitted fluorescent signals. All of these signals could be detected with photoresistors, for which the detection process is illustrated in Figure 4. MCP3008 IC is an 8-channel, 10-bit analog-to-digital converter (ADC), as shown in Figure 5. The analog signals are transformed into digital signals and transmitted to the Raspberry Pi for the detection data analysis. The detection circuit with a photoresistor is illustrated in Figure 5.

This LAMP PCR detection equipment employs photoresistors to read the fluorescent signals emitted from an amplified DNA sample excited with a 365 nm UV light. When the fluorescent signal is brighter, the voltage value of the photoresistor will be higher. A photoresistor has to be in series with a fixed resistor R , highlighted as a red circle in Figure 5, to be able to measure the voltage variances across the photoresistor. However, the resistance value of resistor R will affect the photoresistor voltage variances. Therefore, we had to obtain the optimal resistance value of the connected resistor R . The relationship between the photoresistor and resistor R was measured before and after the photoresistor was excited with UV light, for which the recorded data are shown in Tables 1 and 2, respectively. Both tables indicate that a $150\text{ k}\Omega$ resistor resistance in series exhibits good stability based on the data performance before and after the photoresistor was excited with UV light.

3. Results and Discussion

After completing the entire 60-minute heating reaction, we used UV LEDs to excite the specimens in order to produce fluorescent signals. Then, the positive and negative control specimens were detected using photoresistors to detect the emitted fluorescent signals. The data are shown in Table 3 and Figure 6.

As shown in Figure 6, the emitted fluorescent signals for the positive control specimen after amplification were brighter than that of the unamplified original sample, and the photoresistor voltage signal of the amplified one was 0.145 V higher than the unamplified original sample after a reaction time of 25 minutes, which means that amplified DNA successfully began to bond with fluorescent detection reagent and produced a clone. Furthermore, after reacting for 60 minutes, the brightness of the signal

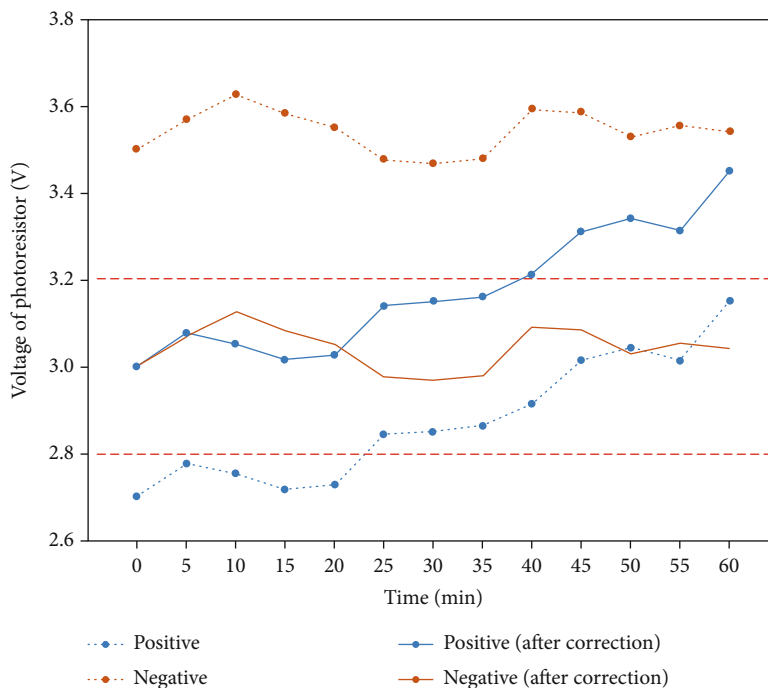

FIGURE 6: Optical detection graph of the LAMP PCR heating process.

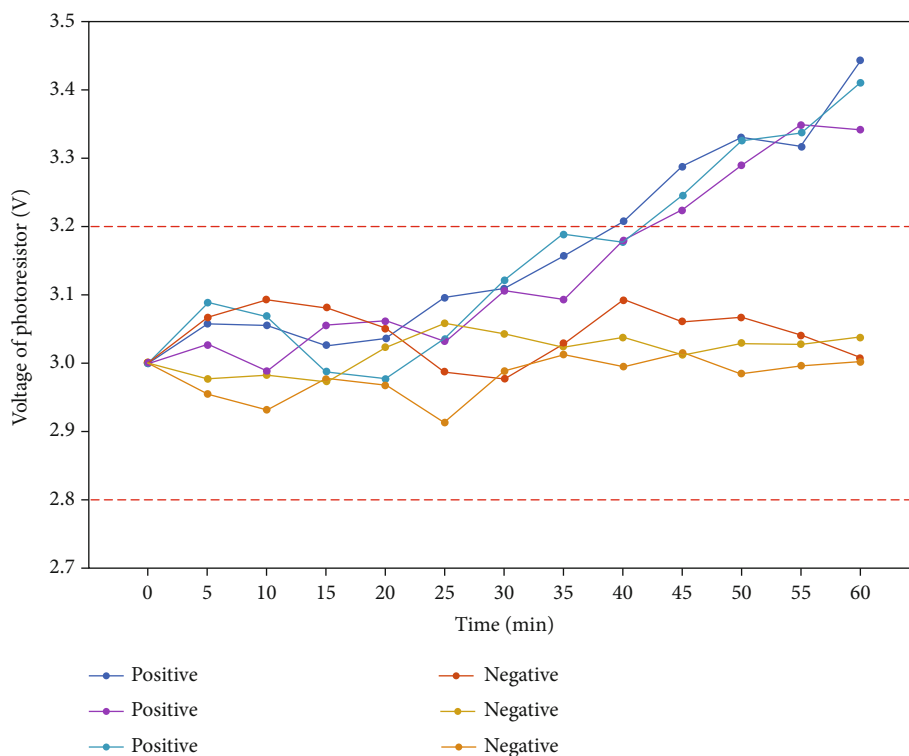

FIGURE 7: Data performance for multiple tubes of samples testing negative/positive simultaneously during LAMP PCR.

for the positive control specimen was obviously brighter than that of the negative control specimen. And the voltage signal detection value of the photoresistor of the positive control specimen was higher than negative control specimen by 0.41 V. We conducted a test by randomly

inserting three tubes of positive samples and three tubes of negative samples in the insertion holes of the reaction tube. The data in Figure 7 clearly show that the detection system could clearly distinguish between the positive and negative samples.

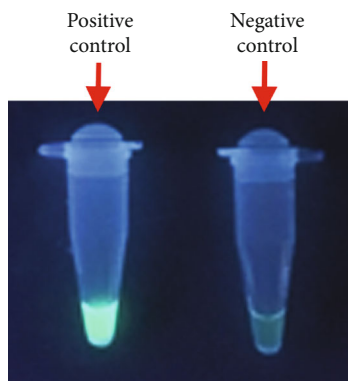

FIGURE 8: The fluorescence of the positive control is brighter than that of the negative control after the successful amplification.

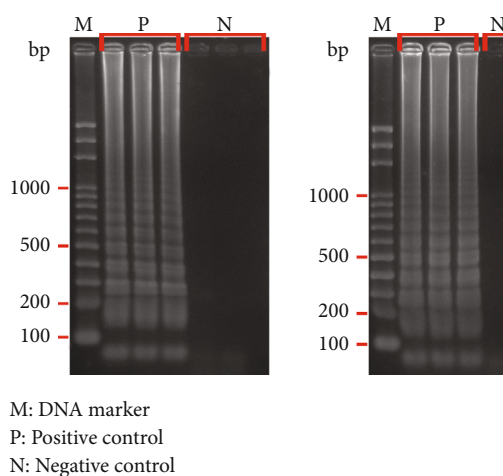

FIGURE 9: LAMP PCR results using an electrophoresis technology analysis.

By the end of the experiment, both the positive and the negative control specimens were directly excited by the 365 nm UV LED wavelengths. From the image shown in Figure 8, it can be observed that after amplification, the positive control specimen produced a very bright fluorescent signal with a wavelength of 515 nm. This result indicates the developed LAMP PCR can amplify the DNA successfully.

In this experiment, a gel electrophoresis analysis was conducted to verify whether the developed LAMP PCR equipment and the LAMP PCR designed specimens would have actual reactions. A gel electrophoresis analysis is a process of separating large molecules from their fragments in order to correctly analyze them. The negatively charged nucleic acid molecules pass through the gel grid influenced by an electric field. This separates the nucleic acid molecules [18]. After the LAMP PCR, the amplified DNA from the positive control specimen produced several different DNA fragments, whereas the negative control specimen did not, as shown in Figure 9.

4. Conclusion

This paper presents LAMP PCR detection equipment. The hardware included a metal heating block designed with SolidWorks and manufactured by a computer numerical

control machine and a fluorescent light detection system based on an optical detection dark box designed with AutoCAD and processed with a laser engraver. The software included an internal control and testing programs written in Java, including the main program and programs used to stabilize the temperature and detect fluorescent signals. After the integration of the detection equipment with the programs, the equipment activated the heating system of the polymerase chain reaction in a period ranging from 15 minutes to one hour. The signals from the fluorescent sample were detected accurately in the optical detection subsystem, where the brightness signals of the positive and negative samples had a difference of 0.41 V. Therefore, compared with current commercial detection products, the developed equipment costs less and works more efficiently. Furthermore, it has more applications. The detection equipment can be used in clinical testing in the future to improve the efficiency of disease screening. Hence, patients with infections can receive proper treatment rapidly, thereby greatly reducing mortality rates.

Data Availability

The data used to support the findings of this study are available from the corresponding author upon request.

Conflicts of Interest

The authors declare no conflict of interest.

Acknowledgments

This research was supported by the Southern Taiwan Science Park Bureau, Taiwan under grant AY-12-03-20-109.

References

- [1] H. A. Erlich, "Polymerase chain reaction," *Journal of Clinical Immunology*, vol. 9, no. 6, pp. 437–447, 1989.
- [2] Y.-C. Lin, M.-Y. Huang, K.-C. Young, T.-T. Chang, and C.-Y. Wu, "A rapid micro-polymerase chain reaction system for hepatitis C virus amplification," *Sensors and Actuators B: Chemical*, vol. 71, no. 1–2, pp. 2–8, 2000.
- [3] M. Li, "Enhancing the efficiency of a PCR using gold nanoparticles," *Nucleic Acids Research*, vol. 33, no. 21, p. e184, 2005.
- [4] Q. Zhao, "Design and numerical analysis of a joule-heating-induced continuous-flow polymerase chain reaction microchip," *Journal of Micro/ Nanolithography, MEMS, and MOEMS*, vol. 8, no. 2, p. 021102, 2009.
- [5] T. Notomi, "Loop-mediated isothermal amplification of DNA," *Nucleic Acids Research*, vol. 28, no. 12, pp. 63e–663, 2000.
- [6] T. Kono, R. Savan, M. Sakai, and T. Itami, "Detection of white spot syndrome virus in shrimp by loop-mediated isothermal amplification," *Journal of Virological Methods*, vol. 115, no. 1, pp. 59–65, 2004.
- [7] S. H. Zarkesh-Esfahani, M. T. Kardi, and M. Edalati, "Hepatitis C virus genotype frequency in Isfahan province of Iran: a descriptive cross-sectional study," *Virology Journal*, vol. 7, no. 1, 2010.
- [8] S. Fukuta, T. Iida, Y. Mizukami et al., "Detection of Japanese yam mosaic virus by RT-LAMP," *Archives of Virology*, vol. 148, no. 9, pp. 1713–1720, 2003.
- [9] S. Fukuta, S. Kato, K. Yoshida et al., "Detection of tomato yellow leaf curl virus by loop-mediated isothermal amplification reaction," *Journal of Virological Methods*, vol. 112, no. 1–2, pp. 35–40, 2003.
- [10] M. Ihira, T. Yoshikawa, Y. Enomoto et al., "Rapid diagnosis of human herpesvirus 6 infection by a novel DNA amplification method, loop-mediated isothermal amplification," *Journal of Clinical Microbiology*, vol. 42, no. 1, pp. 140–145, 2004.
- [11] C. H. Wang, K. Y. Lien, J. J. Wu, and G. B. Lee, "A magnetic bead-based assay for the rapid detection of methicillin-resistant *Staphylococcus aureus* by using a microfluidic system with integrated loop-mediated isothermal amplification," *Lab on a Chip*, vol. 11, no. 8, pp. 1521–1531, 2011.
- [12] L. L. M. Poon, C. S. W. Leung, M. Tashiro et al., "Rapid detection of the severe acute respiratory syndrome (SARS) coronavirus by a loop-mediated isothermal amplification assay," *Clinical Chemistry*, vol. 50, no. 6, pp. 1050–1052, 2004.
- [13] K. Yasuda, K. Okano, and S. Ishiwata, "Focal extraction of surface-bound DNA from a microchip using photo-thermal denaturation," *BioTechniques*, vol. 28, no. 5, pp. 1006–1011, 2000.
- [14] A. Sappat, S. Mongpraneet, T. Lomas, and A. Tuantranont, "Multi-channel turbidity detection of shrimp virus by loop-mediated isothermal amplification reaction," in *IEEE SENSORS 2009 Conference*, New Zealand, 2009.
- [15] J. Zhou, Y. Liao, H. Li et al., "Development of a loop-mediated isothermal amplification assay for rapid detection of *Trichosporon asahii* in experimental and clinical samples," *BioMed Research International*, vol. 2015, Article ID 732573, 9 pages, 2015.
- [16] J. Kashir and A. Yaqinuddin, "Loop mediated isothermal amplification (LAMP) assays as a rapid diagnostic for COVID-19," *Medical Hypotheses*, vol. 141, no. 109786, p. 109786, 2020.
- [17] J. Rödel, R. Egerer, A. Suleyman et al., "Use of the variplex™ SARS-CoV-2 RT-LAMP as a rapid molecular assay to complement RT-PCR for COVID-19 diagnosis," *Journal of Clinical Virology*, vol. 132, no. 104616, p. 104616, 2020.
- [18] C. Aaij and P. Borst, "The gel electrophoresis of DNA," *Biochimica et Biophysica Acta (BBA)-Nucleic Acids and Protein Synthesis*, vol. 269, no. 2, pp. 192–200, 1972.