

Research Article

Glass Fibre Reinforced Epoxy Composites Modified with Graphene Nanofillers: Electrical Characterization

Lokasani Bhanuprakash ^{1,2}, Soney Varghese ² and Sitesh Kumar Singh ³

¹Department of Mechanical Engineering, MLR Institute of Technology, Hyderabad 500043, India

²Nanomaterials and Devices Research Laboratory, School of Nano Science and Technology, National Institute of Technology Calicut, Kerala 673601, India

³College of Engineering and Technology, Wollega University, Nekemte, Ethiopia

Correspondence should be addressed to Lokasani Bhanuprakash; lokasanibhanu@gmail.com and Sitesh Kumar Singh; sitesh@wollegauniversity.edu.et

Received 5 August 2022; Revised 24 August 2022; Accepted 1 September 2022; Published 20 September 2022

Academic Editor: Senthilkumar N

Copyright © 2022 Lokasani Bhanuprakash et al. This is an open access article distributed under the Creative Commons Attribution License, which permits unrestricted use, distribution, and reproduction in any medium, provided the original work is properly cited.

Composites with improved electrical properties created new pathways in electrical engineering industries. In this work, electrical studies conducted on continuous unidirectional E-glass fibre-reinforced epoxy composites modified with three different graphite oxide fillers are discussed. The three different fillers are (i) graphite oxide (GO), (ii) exfoliated graphite oxide (EGO), and (iii) reduced exfoliated graphite oxide (rEGO). Incorporation of GO fillers exhibited significant improvement in the dielectric characteristics of the composites, where it showed 42% enhancement in breakdown strength values. Dielectric constant measurements of GO-filled composites have also demonstrated considerable enhancement in the values where the fillers promoted interfacial and dipolar polarization phenomena in the material. On the other hand, in the case of EGO and rEGO fillers, conducting nature induced from graphitic structure had significantly reduced the dielectric properties of their composites.

1. Introduction

Due to their versatile properties, glass fibre-reinforced epoxy composites are found extensively used in many engineering sectors such as aerospace, automobile, and civil. In the last two decades, composites with improved electrical properties have created new pathways in electrical engineering industries. For example, a joint venture undertaken by ABB Plast and ABB Components have developed glass fibre-reinforced composites with improved dielectric and mechanical properties for meeting the design specifications of a cylinder used in transformer tap changers [1]. Other potential applications for these composites are high-voltage switchgear, composite cylinders as an alternative to porcelain insulators, electrical insulation for superconducting magnets or magnetic components, etc. [2–5]. Recently, Volvo Car Corporation partnering with researchers from Imperial College London have developed a multifunctional structural composite material by combining carbon fibres, fibreglass, and a polymer resin

for primarily using it as a car body structure and secondarily as a battery [6, 7]. Aerospace industries are obviously more interested in employing such composites to gain the extra mileage by increasing fuel efficiency and for storing the electrical energies. In general, these industries often demand for materials which are highly reliable and highly durable (damage-tolerant) in nature. When an electrical equipment is in operation, the insulating materials (mostly epoxy resin) used in the equipment often subject to varieties of electrical discharges. The constant bombardment of electrons and ions generated by discharges produces heat and deteriorates the properties of insulating materials, in turn causing degradation of the material. Thus, the durability of insulating materials is dependent on trapped electrical charges [8], and hence, it is recommended that the insulating materials which are employed in the electrical environments should possess significantly high electrical breakdown strength values.

Glass fibre-reinforced epoxy composites are used for making radar domes (radomes), which is a protective

dielectric housing for a microwave antenna that transmits selective electromagnetic waves [9]. One of the attractive characteristics of these composites is that it possess high damage tolerances because of their ability to resist micro-damage development events such as matrix cracking, delamination, and fibre cracking. Thus, glass fibre-reinforced composites have found a place in the electrical industry as an important class of low dielectric material since they are good electrical insulators possessing low dielectric loss and excellent mechanical properties [10].

The role of fibre-matrix interface and fibre orientation on the dielectric properties of glass fibre-reinforced epoxy composites were studied by Kechaou et al. using the scanning electron microscope mirror effect (SEMME) technique [11]. The SEMME method can be applied to any insulating material, and their ability to trap or diffuse electric charges can be known. In general, epoxy matrix being an insulating material can trap a high amount of charges and long fibres can allow the diffusion of trapped charges along the interface [12]; however, Kchaou and their team's studies on the role of the fibre-matrix interface demonstrated that the interfacial zone is also playing a considerable role in trapping the charges. Hence, a high interface strength medium which can diffuse the trapped charges and is linked to localized polarization energies is recommended for obtaining high dielectric properties to the materials. Dielectric properties of woven glass fibre-reinforced polymer composites were studied in the THz frequency by Kimiyoshi et al., where they identified that the real part of the complex dielectric constant was frequency independent in the 0.2 to 1 THz range and the imaginary part of the dielectric constant was linearly increasing with increasing frequencies in the range of 0.1 to 0.33 THz [10]. Investigations on the dielectric properties of high-performance bishphthalonitrile/polyarylene ether nitrile/glass fibre composite laminates had shown little dependence on frequency [13]. Glass fibre/epoxy composites loaded with plasma-synthesized aluminium nitride powder (10 wt.%) showed enhanced dielectric breakdown strength of 30.26 kV/mm [14]. The addition of three additives, i.e., thiokol, epoxidized natural rubber, and epoxidized linseed oil to the glass fibre-reinforced epoxy composites, had found no significant effect on the dielectric properties [15].

Studies on the dielectric properties of composite materials were often used for evaluating the damage phenomenon occurring in the composites [6]. Fazzino and his group have used electrochemical impedance spectroscopy to characterize the damage initiation and progression in woven glass fibre-reinforced epoxy composites [16]. In measuring the damage developed, they obtained larger, more consistent, and clearer distinctions compared to common methods which work based on physical properties or visual assessments. The effect of electric stress on glass fibre-reinforced epoxy composites under a wet environment has been examined by Gao et al., where they studied morphological changes in the composite surfaces and development trend of current for assessing the degradation process of composites [3].

In recent years, interest on natural fibre-reinforced polymer composites has been growing wider, which is mainly

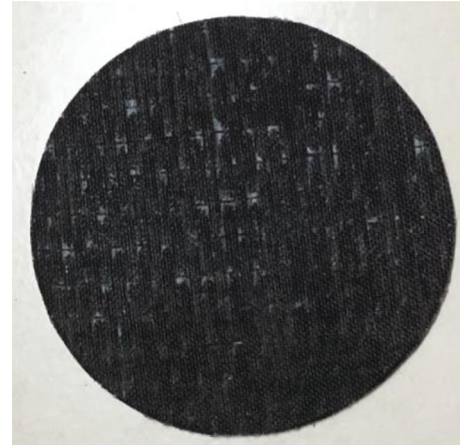

FIGURE 1: Photograph of composite test specimen (circular disc) for electrical characterization.

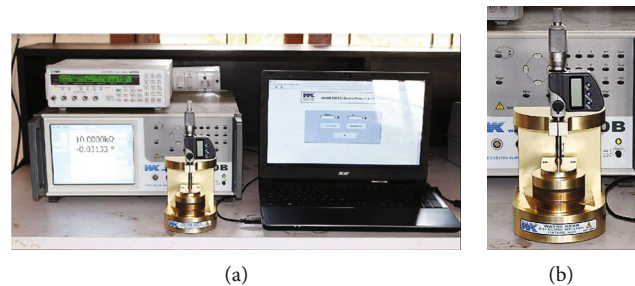

FIGURE 2: Photographs of the Impedance analyser test setup (a) for dielectric characterization of samples; sample holder (b).

due to the features of natural fibres, i.e., low cost, low density, ease in its processing, and being renewable and biodegradable in nature [17–20]. Elammaran and coworkers have conducted a comparative study on the dielectric properties of synthetic (glass) and natural (bamboo) fibre-reinforced epoxy composites [19]. They noticed all the composites showing improved dielectric properties compared to pure epoxy resin in which only instantaneous atomic and ionic polarizations are possible. With the concentration of fibres increasing in the matrix, the dielectric properties of composites were also improved; however, at higher concentrations (20 wt.%), the amount of free charges accumulating at the interface was found to be increased, leading to higher interfacial polarization resulting in lower dielectric properties. Incorporating glass fibres in chopped form in the epoxy composites demonstrated higher dielectric properties compared to bamboo fibres. In general, natural fibres show lower modulus, lower strength, and higher moisture absorption; to overcome these limitations, natural fibres are combined with synthetic fibres at an optimized ratio in fabricating their hybrid composites [20]. Dielectric properties of *Roystonea regia* fibres combined with glass fibres/epoxy composites were studied by Goud and Rao, where they identified an increase in glass fibre content in the hybrid composites which resulted in a decrease in dielectric constant values at all the frequencies [20]. The addition of more

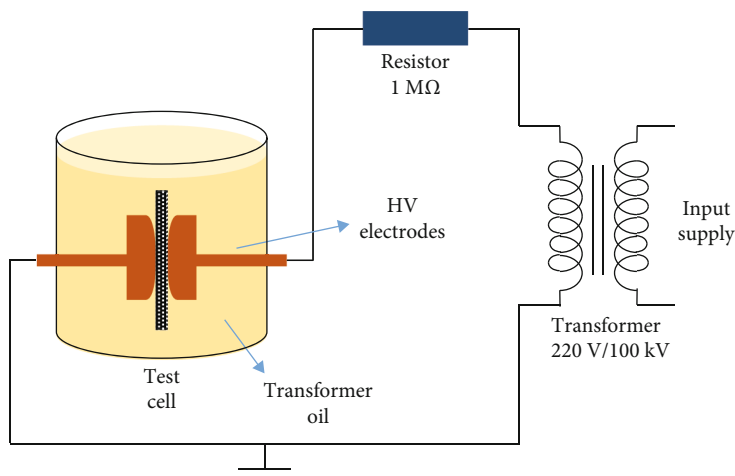

FIGURE 3: Schematic diagram of the experimental setup for AC dielectric breakdown voltage measurements.

amounts of glass fibres in the hybrid system caused a reduction in availability of polar groups; as a result, a decrease in dielectric constant values is observed.

In the present investigation, the dielectric properties of glass fibre-reinforced epoxy composites modified with three different graphene fillers are studied. The three different forms of graphene fillers incorporated are graphite oxide (GO), exfoliated GO (EGO), and reduced EGO (rEGO). The measurements of dielectric constant, loss factors, and dielectric breakdown strength are obtained according to the corresponding ASTM standards.

2. Experimental

2.1. Materials. Bisphenol-based epoxy resin (epofine 1564) and polyetheramine-based hardener (finehard 3486) procured from Fine Finish Organics Pvt. Ltd., India, are used as the matrix system. An E-glass fabric of 500 gsm purchased from Urja Products Pvt., Ltd., India, is used as reinforcement system for the composite. Different variants of graphene prepared in the laboratory are used for the work. All the materials used in this work are the same as mentioned in our earlier published work [21, 22]. The materials and the method description partly reproduces the wording [21, 22].

2.2. Preparation of Composites. Hybrid glass fibre-reinforced epoxy composites were fabricated by varying concentrations of GO, EGO, and rEGO fillers at 0.5, 1, and 2.5 wt.%, respectively, through a simple hand layup method using the vacuum bagging technique. The fabrication methodology of composite laminates is the same as discussed in our earlier work [21, 22]. The composites prepared for different electrical tests have used 4 fabric plies to produce laminate thicknesses in the range of 1–1.3 mm. Test specimens were cut into 75 mm diameter circular discs (Figure 1).

2.3. Characterization. The dielectric characteristics of composites are measured using an Impedance analyser (Wayne Kerr Electronics) using an in-house-developed sam-



FIGURE 4: Photographs of the AC dielectric breakdown test setup and sample holder (inset picture).

TABLE 1: Dielectric breakdown strength measurements of all the composites.

	Breakdown strength (kV/mm)		% change
	Mean	S.D.	
Baseline	21.59	0.54	
EP-GO (0.5)	22.94	2.11	6.25
EP-GO (1)	30.69	2.19	42.14
EP-GO (2.5)	29.43	1.77	36.31
EP-EGO (0.5)	18.18	1.00	-15.79
EP-EGO (1)	10.17	3.03	-52.89
EP-EGO (2.5)	8.15	2.20	-62.25
EP-rEGO (0.5)	13.33	0.64	-38.25
EP-rEGO (1)	8.7	2.34	-59.7
EP-rEGO (2.5)	7.46	1.26	-65.44

ple holder by scanning at a frequency range of 20 Hz to 1 MHz with a bias voltage of 1 V. The sample holder employed is a spring-controlled one so that a good contact between the sample and electrodes is achieved. The samples of diameter 75 mm and thickness about 1 mm were used for testing. Photographs of the Impedance analyser instrument and the sample holder are shown in Figure 2. Breakdown

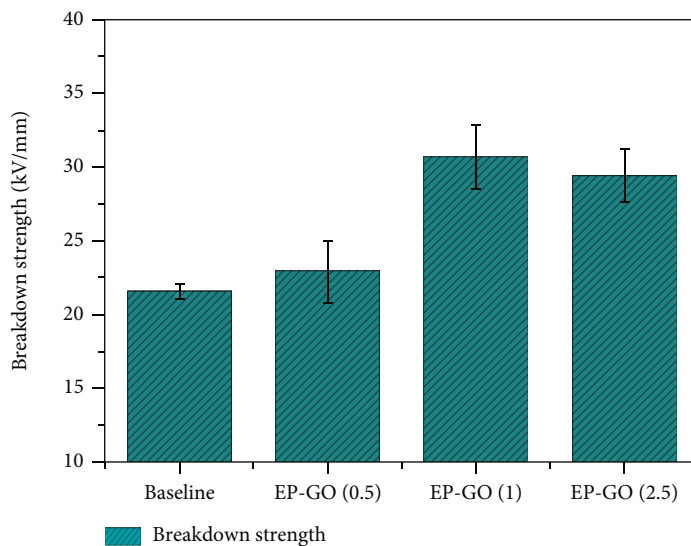

FIGURE 5: Dielectric breakdown strength measurements of glass fibre-reinforced composites filled with GOs.

voltage measurements are obtained from an experimental setup (Figure 3) designed according to ASTM D149 [23].

Photographs of the breakdown voltage instrument setup and the sample holder are shown in Figure 4. Here, 25 mm diameter high-voltage (HV) electrodes with an edge radius of 3.2 mm were chosen for conducting the experiments. To avoid surface flashover, the complete electrode assembly was submerged in transformer oil. By applying an AC voltage to the HV electrodes, breakdown strength experiments were performed at a rate of 0.5 kV/sec until the sample got punctured. As the voltage increased, bubbling in the oil was observed near the end of the electrodes at the curved region. Most of the samples have noticed puncturing at the regions close to the electrode contact points, and the corresponding voltage was recorded for calculating the breakdown strength. The dielectric breakdown strength was calculated according to the equation: $E = V/d$, where V is the breakdown voltage and d is the thickness of the sample close to the point at which the puncture took place. At least five specimens were tested in each configuration, and the average values were plotted.

3. Results and Discussion

3.1. Dielectric Breakdown Strength Measurements. Dielectric breakdown strength is defined as the maximum voltage at which material gets punctured to the thickness of the material near the point of puncture. Breakdown in polymer-based insulators occurs at a point close to the electrodes, which is a catastrophic failure that generally is an irreversible and destructive process. In solid materials, breakdown occurs due to long-interval partial discharges which generate heat and cause degradation of the material near the area of electrodes. The continued discharges eventually char the material and allow the current to conduct through a passage of carbonized material. The AC dielectric breakdown studies of glass fibre-reinforced epoxy composites modified with three different graphene fillers were carried out according

to ASTM standard D149, and the values of corresponding composites are summarized in Table 1.

The dielectric breakdown strength measurements of GO-filled epoxy composites are shown in Figure 5. The breakdown strength of the baseline glass fibre/epoxy composite system is measured as 21.6 kV/mm. It can be observed from the results that the breakdown strength measurements of GO-filled glass fibre-reinforced composites have noticed a significant improvement in their values, where the maximum enhancement of 42% was noted with 1 wt.% of GO fillers. The improvement in breakdown values for 0.5 wt.% GO-filled composites is found to be marginal compared to baseline ones. As the concentration of GOs increased in the composite system, the strength values reached a maximum value at 1 wt.% and then values started decreasing by showing an enhancement of 36% at 2.5 wt.%. At a lower concentration of fillers, the availability of fillers in the matrix resin will be small and the interlayer distances between them will become more. Consequently, the volume fraction of the pure polymer will become more. In this scenario, when a high amount of electric stress is applied, the mobility of charges between the electrodes becomes easier through the loose polymer [24].

The above results can be explained with the understanding of the key differences possessed by these three filler materials, GO, EGO, and rEGO. The critical characterization of the GO, EGO, and rEGO fillers was conducted, and the results were discussed in our earlier works [21]. In brief, GO fillers are observed with oxygen-containing functional groups such as hydroxyl, epoxide, carbonyl, and carboxyl groups with disordered morphology. The exfoliation and chemical reduction of GO resulted in EGO and rEGO fillers, which have removed these functional groups in both cases and restored the graphitic structure with expanded sheets with wrinkles at the edges and thin and fluffy morphology, respectively.

Graphite oxide being in oxide form acts as an insulating material, the insulating behaviour of which is purely

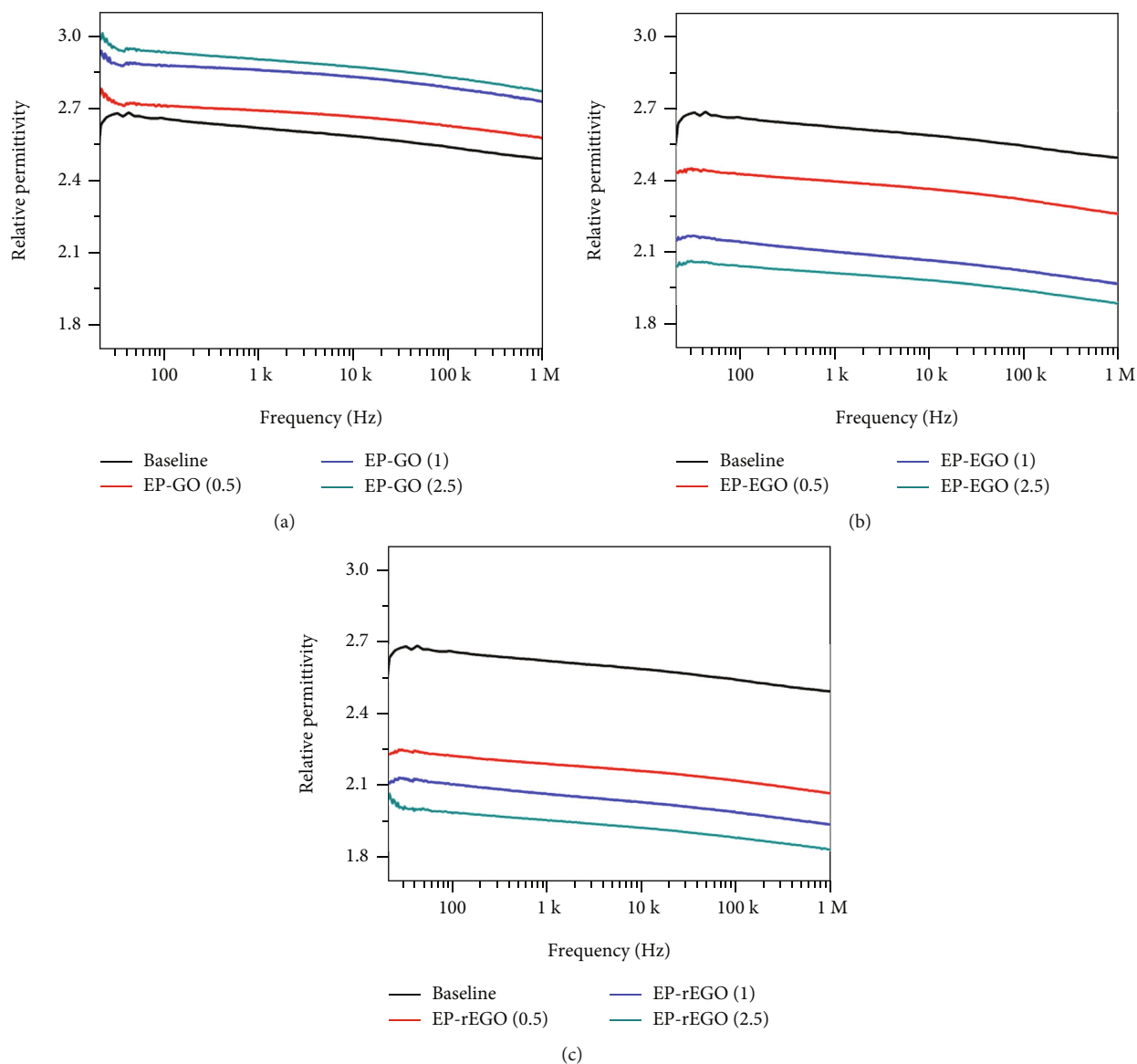

FIGURE 6: Dielectric constant measurements of glass fibre/epoxy composites modified with graphite oxide derivatives.

dependent on the degree of oxidation. The difference in permittivity values between matrix resin and filler material causes field enhancement near the particles leading to partial discharges. However, it is probable that the field enhancement can occur due to the presence of voids; hence, it cannot provide sufficient explanations for breakdown phenomena [25]. The synergetic effect of surface discharges, the localized partial discharges at particle sites, and the ease in mobility of charges through loose polymers will dictate the final breakdown of the material [8]. In the case of GO fillers, the functional groups present on their surfaces can form hydrogen bonds with the matrix resin and they can form secondary bonds with the reinforcement fibres as well. When the loading of GO increased in the matrix resin, GO fillers tightly bind with the matrix resin; as a result, the packing density and interfacial polarization predominantly get improved in the composite system. In addition, the mobility of charges through dense matrix resin will become tough and space

charge distribution will be altered. All these factors contribute to oppose the flow current between the electrodes, which leads to enhanced dielectric breakdown values for the materials. On the other hand, composites modified with EGO and rEGO fillers have observed a deterioration in breakdown strength values. As the concentration of EGO and rEGO fillers increases, the dielectric breakdown strength values of composites were found to be decreased. It is mainly attributed to the conducting nature of the fillers. In the case of EGO, thermal exfoliation of GO caused defunctionalization and partial restoration of the graphitic structure. In case of rEGO, the chemical reduction treatment involved in its production has removed most of the functional groups and restored the graphene structure. The conducting behaviour of EGO and rEGO fillers has dramatically tailored the composite charge storage and dissipation capabilities, and they promoted the flow of current between the electrodes.

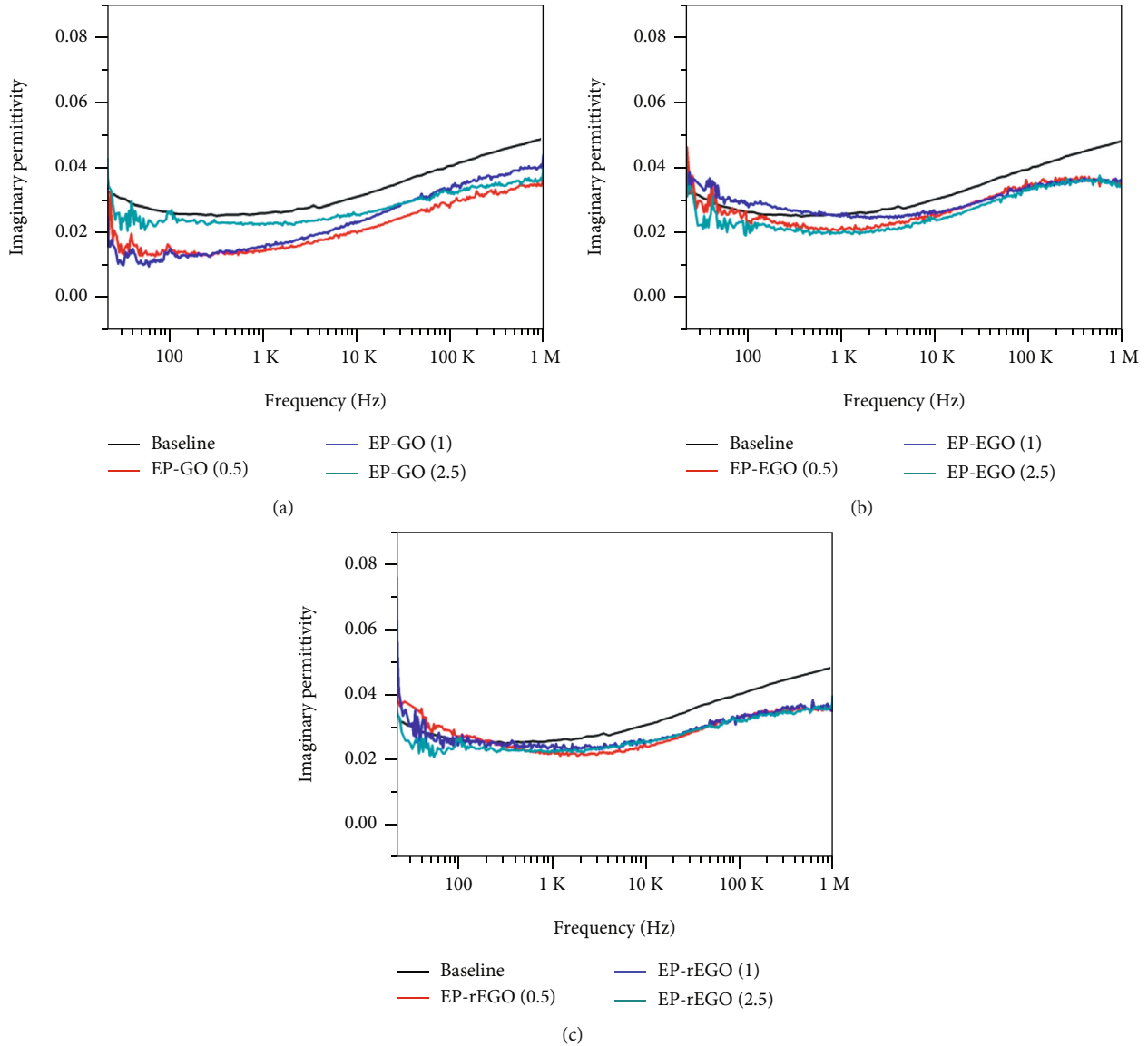

FIGURE 7: Imaginary permittivity measurements of glass fibre/epoxy composites modified with graphite oxide derivatives.

3.2. Dielectric Constant and Dielectric Loss Measurements. When an electric field is applied to a dielectric material, induced electric charges shift from its equilibrium positions causing dielectric polarization. The measure of polarizability of a material is known as dielectric property. It is an important property which provides information regarding storage and dissipation of electric and magnetic energies in the material. The permittivity (ϵ) is also commonly referred to as the dielectric constant of material, which represents the material's ability to store electrical energy with the applied electric field. Dielectric constant is the measure of relative permittivity (ϵ_r) of a material, which is defined as the permittivity of a material relative to the permittivity of a vacuum. The real part of relative permittivity (ϵ') indicates the ability of material to store the electric energies, whereas the imaginary part (ϵ'') gives the measure of energy loss. Figure 6 presents the relative permittivity measurements of nanofiller-incorporated glass fibre-reinforced epoxy com-

posites. These measurements were carried out in the frequency range from 20 to 1 MHz using an Impedance analyser. It can be observed from the graphs that the real permittivity values increased with the decrease in frequencies, which is mainly due to the space charge polarization as well as dipolar polarization [26]. When an alternating electric field is applied, the dipolar groups present in the material will orient at lower frequencies in the direction of flow of current. At higher frequencies, the dipoles which are big in size will not get sufficient time to orient in the direction of flow of current and thus it notices a decrease in permittivity values.

GO-filled composites have shown improved dielectric properties compared to the unmodified composites, where the relative permittivity values were found to be increased with the increase in loading concentration of GOs. Typically, in the baseline glass fibre/epoxy composite system, polar groups such as $-\text{NH}_2$ and $-\text{NH}$ from curing agents, epoxide,

hydroxyl groups, and a few secondary bonds were available for dipole polarization. Through the addition of GO fillers, a new bond formation takes place between the matrix and the fillers and between the reinforcement and the fillers. These additional bonding groups provide the extra dipoles to orient in the direction of flow of current which leads to an increase in permittivity values [27]. Graphite oxide being an insulating material, it can trap significant amount of charges within and at the interfaces, which eventually increases the space charge accumulation at the electrodes. The synergic effect of all these factors contributes in improving the permittivity of values of GO-filled glass fibre composites [28]. On the other side, EGO and rEGO fillers being conductive in nature, they allow the flow of current through them without the accumulation of charges leading to deterioration of the permittivity values. The same was confirmed in the results which shows the decrease in permittivity values is reciprocal to the increase in loading concentrations of EGO and rEGO fillers (Figure 6).

The imaginary part of permittivity illustrates the losses involved in a dielectric material due to the storage and dissipation of electrical charges. Figure 7 shows the imaginary permittivity measurements of glass fibre-reinforced epoxy composites modified with graphite oxide derivatives as a function of frequency. The loss factor in all the composites was found to be decreased with the incorporation of graphene-based fillers. Particularly, GO-filled composites demonstrated significantly lower values compared to the baseline system. It indicates that with the incorporation of GO fillers, composites have improved the storage capabilities of the charges and minimized the occurring losses. On the other hand, at lower frequencies, EGO- and rEGO-filled composites showed imaginary permittivity values close to the baseline composite. With the increase in frequency, these composites showed lower dielectric loss values which may be attributed to the conductive nature of the EGO and rEGO fillers.

4. Conclusions

Dielectric characteristics of E-glass fibre-reinforced epoxy composites modified with graphite oxide derivatives were studied according to relevant ASTM standards, where graphite oxide-filled composites have shown enhancement in dielectric breakdown strength and dielectric constant values. At 1 wt.% of GOs, glass fibre composites have noticed the highest improvement in breakdown strength values gaining by 42%. With the increase in concentration of GOs, dielectric constant measurements also showed significant enhancements in their values. Oxygen-containing functional groups present on the surfaces of GOs were found involved in covalent bonds such as hydrogen with the epoxide matrix, which created new interface regions. The newly formed interface regions participated in polarization upon the application of an external electric field. In addition, the dipoles created during the covalent bonds are also involved in dipolar polarization. The synergetic effect of this phenomenon contributed in improving the dielectric properties of GO-filled glass fibre/epoxy composites. On the other hand,

the conducting nature of EGO and rEGO fillers was found to be reducing the dielectric breakdown strength and dielectric constant values by allowing the flow of current between the electrodes. Imaginary permittivity measurements of all the composites modified with fillers have shown considerable reduction in dielectric losses occurring during the storage and dissipation of electric charges.

Data Availability

The datasets generated during and/or analysed during the current study are available from the corresponding author on reasonable request.

Additional Points

Supporting Information. The materials used, preparation of graphene nanofillers, fabrication of composites and characterization of nanofillers are clearly discussed in our earlier publications [21, 22]. The hyperlinks for the same is as followed: 21. doi:10.1002/pc.24809 22. doi:10.1016/j.compscitech.2019.04.034

Conflicts of Interest

The authors declares that there is no conflict of interest regarding the publication of this article.

References

- [1] A. Strombeck and T. Larsson, "Fiber-reinforced composites-extra mechanical and electrical strength for transformer tap-changers," *Composite Materials*, vol. 42, pp. 38–42, 1999.
- [2] S. Li, H. Tsang, Y. Cheng, and Z. Lu, "Seismic testing and modeling of cylindrical electrical equipment with GFRP composite insulators," *Composite Structures*, vol. 194, pp. 454–467, 2018.
- [3] Y. Gao, X. Liang, Y. Liu, W. Bao, S. Li, and C. Wu, "Effect of electrical stress on glass fiber reinforced polymer used in high voltage composite insulator under wet environment," *Composites Science and Technology*, vol. 155, pp. 151–159, 2018.
- [4] S. Rajiv, V. L. Tanna, C. V. S. Rao et al., "Development of indigenous insulation material for superconducting magnets and study of its characteristics under influence of intense neutron irradiation," in *IOP Conference Series: Materials Science and Engineering, Volume 171, 26th International Cryogenic Engineering Conference & International Cryogenic Materials Conference*, New Delhi, India, 2017.
- [5] K. P. Weiss, S. Westenfelder, A. Jung, N. Bagrets, and W. Fietz, "Determination of mechanical and thermal properties of electrical insulation material at 4.2 K," *AIP Conference Proceedings*, vol. 1435, pp. 148–155, 2012.
- [6] M. R. Raihan, "Dielectric properties of composite materials during damage accumulation and fracture. Doctor of philosophy PhD dissertation," in *Mechanical Engineering*, University of South Carolina, Columbia, USA, 2014.
- [7] "Volvo develops body panels that serve as batteries." April 2021, <http://www.carbodydesign.com/2013/10/volvo-develops-body-panels-that-serve-as-batteries/>.

- [8] P. Preetha and M. J. Thomas, "AC breakdown characteristics of epoxy nanocomposites," *IEEE Transactions on Dielectrics and Electrical Insulation*, vol. 18, no. 5, pp. 1526–1534, 2011.
- [9] P. C. Kim, D. G. Lee, W.-G. Lim, and I. S. Seo, "Polarization characteristics of a composite stealth radome with a frequency selective surface composed of dipole elements," *Composite Structures*, vol. 90, no. 2, pp. 242–246, 2009.
- [10] K. Naito, Y. Kagawa, S. Utsuno, T. Naganuma, and K. Kurihara, "Dielectric properties of woven fabric glass fiber reinforced polymer-matrix composites in the THz frequency range," *Composites Science and Technology*, vol. 69, no. 11–12, pp. 2027–2029, 2009.
- [11] B. Kechaou, M. Salvia, K. Benzarti, C. Turki, Z. Fakhfakh, and D. Tréheux, "Role of fiber/matrix interphases on dielectric, friction, and mechanical properties of glass fiber-reinforced epoxy composites," *Journal of Composite Materials*, vol. 46, no. 2, pp. 131–144, 2012.
- [12] B. Kchaou, C. Turki, M. Salvia, Z. Fakhfakh, and D. Tréheux, "Role of fibre-matrix interface and fibre direction on dielectric behaviour of epoxy composites," *Composites Science and Technology*, vol. 64, no. 10–11, pp. 1467–1475, 2004.
- [13] Z. Chen, Y. Lei, H. Tang, J. Wei, and X. Liu, "Mechanical, thermal, electrical, and interfacial properties of high-performance bisphthalonitrile/polyarylene ether nitrile/glass fiber composite laminates," *Polymer Composites*, vol. 34, no. 12, pp. 2160–2168, 2013.
- [14] P. Panda, G. Mishra, S. Mantry, S. K. Singh, and S. P. Sinha, "A study on mechanical, thermal, and electrical properties of glass fiber-reinforced epoxy hybrid composites filled with plasma-synthesized AlN," *Journal of Composite Materials*, vol. 48, no. 25, pp. 3073–3082, 2014.
- [15] C. M. Vu, L. T. Nguyen, T. V. Nguyen, and H. J. Choi, "Effect of additive-added epoxy on mechanical and dielectric characteristics of glass fiber reinforced epoxy composites," *Polymer Korea*, vol. 38, no. 6, pp. 726–734, 2014.
- [16] P. D. Fazzino, K. L. Reifsnider, and P. Majumdar, "Impedance spectroscopy for progressive damage analysis in woven composites," *Composites Science and Technology*, vol. 69, no. 11–12, pp. 2008–2014, 2009.
- [17] P. A. Sreekumar, J. M. Saiter, K. Joseph, G. Unnikrishnan, and S. Thomas, "Electrical properties of short sisal fiber reinforced polyester composites fabricated by resin transfer molding," *Composites. Part A, Applied Science and Manufacturing*, vol. 43, no. 3, pp. 507–511, 2012.
- [18] Z. Ghallabi, H. Rekik, S. Boufi, M. Arous, and A. Kallel, "Effect of the interface treatment on the dielectric behavior of composite materials of unsaturated polyester reinforced by alfa fiber," *Journal of Non-Crystalline Solids*, vol. 356, no. 11–17, pp. 684–687, 2010.
- [19] J. Elammaran, T. C. Peng, B. M. K. Bin, and K. Akshay, "Comparative analysis on dielectric properties of polymer composites reinforced with synthetic and natural fibers," *Journal of Vinyl & Additive Technology*, vol. 24, pp. E201–E216, 2018.
- [20] G. Goud and R. N. Rao, "Mechanical and electrical performance of Roystonea regia/glass fibre reinforced epoxy hybrid composites," *Bulletin of Materials Science*, vol. 35, no. 4, pp. 595–599, 2012.
- [21] L. Bhanuprakash, A. Ali, R. Mokkoth, and S. Varghese, "Mode I and mode II interlaminar fracture behavior of E-glass fiber reinforced epoxy composites modified with reduced exfoliated graphite oxide," *Polymer Composites*, vol. 39, no. S4, pp. E2506–E2518, 2018.
- [22] L. Bhanuprakash, S. Parasuram, and S. Varghese, "Experimental investigation on graphene oxides coated carbon fibre/epoxy hybrid composites: mechanical and electrical properties," *Composites Science and Technology*, vol. 179, pp. 134–144, 2019.
- [23] American Society for Testing and Materials, *Standard Test Method for Dielectric Breakdown Voltage and Dielectric Strength of Solid Electrical Insulating Materials at Commercial Power Frequencies*, ASTM International, 2013.
- [24] T. Tanaka, "Dielectric nanocomposites with insulating properties," *IEEE Transactions on Dielectrics and Electrical Insulation*, vol. 12, no. 5, pp. 914–928, 2005.
- [25] R. Lovell, "The effect of specimen size on the electric breakdown of unfilled and filled epoxy polymers," *IEEE Transactions on Electrical Insulation*, vol. EI-11, no. 4, pp. 110–114, 1976.
- [26] P. Preetha, M. J. Thomas, and R. Ranjan, "Electrothermal ageing of epoxy nanocomposites," *IEEE Transactions on Dielectrics and Electrical Insulation*, vol. 19, no. 6, pp. 2081–2089, 2012.
- [27] K. C. Kao, *Dielectric Phenomena in Solids: With Emphasis on Physical Concepts of Electronic Processes*, Elsevier, USA, 1st edition, 2004.
- [28] P. Preetha and M. J. Thomas, "Partial discharge resistant characteristics of epoxy nanocomposites," *IEEE Transactions on Dielectrics and Electrical Insulation*, vol. 18, no. 1, pp. 264–274, 2011.