

## *Retraction*

# **Retracted: On the Performance and Efficiency of Surface Air Cooler Working under High Temperature and High Humidity Condition**

### **Journal of Robotics**

Received 23 January 2024; Accepted 23 January 2024; Published 24 January 2024

Copyright © 2024 Journal of Robotics. This is an open access article distributed under the Creative Commons Attribution License, which permits unrestricted use, distribution, and reproduction in any medium, provided the original work is properly cited.

This article has been retracted by Hindawi following an investigation undertaken by the publisher [1]. This investigation has uncovered evidence of one or more of the following indicators of systematic manipulation of the publication process:

- (1) Discrepancies in scope
- (2) Discrepancies in the description of the research reported
- (3) Discrepancies between the availability of data and the research described
- (4) Inappropriate citations
- (5) Incoherent, meaningless and/or irrelevant content included in the article
- (6) Manipulated or compromised peer review

The presence of these indicators undermines our confidence in the integrity of the article's content and we cannot, therefore, vouch for its reliability. Please note that this notice is intended solely to alert readers that the content of this article is unreliable. We have not investigated whether authors were aware of or involved in the systematic manipulation of the publication process.

Wiley and Hindawi regrets that the usual quality checks did not identify these issues before publication and have since put additional measures in place to safeguard research integrity.

We wish to credit our own Research Integrity and Research Publishing teams and anonymous and named external researchers and research integrity experts for contributing to this investigation.

The corresponding author, as the representative of all authors, has been given the opportunity to register their agreement or disagreement to this retraction. We have kept a record of any response received.

### **References**

- [1] J. Yang, J. Yu, S. Wang, and W. Yan, "On the Performance and Efficiency of Surface Air Cooler Working under High Temperature and High Humidity Condition," *Journal of Robotics*, vol. 2022, Article ID 8656289, 11 pages, 2022.

## Research Article

# On the Performance and Efficiency of Surface Air Cooler Working under High Temperature and High Humidity Condition

Juan Yang, Jing Yu , Shijing Wang, and Weidong Yan

*School of Intelligent Engineering Technology, Jiangsu Vocational Institute of Commerce, Nanjing, Jiangsu 211199, China*

Correspondence should be addressed to Jing Yu; 18251853848@163.com

Received 12 August 2022; Revised 29 August 2022; Accepted 30 August 2022; Published 28 September 2022

Academic Editor: Shahid Hussain

Copyright © 2022 Juan Yang et al. This is an open access article distributed under the Creative Commons Attribution License, which permits unrestricted use, distribution, and reproduction in any medium, provided the original work is properly cited.

Surface air cooler is widely used in refrigeration, air conditioning, chemical dehumidification, and other related fields. Nowadays, the application of surface air cooler has been mature under standard working conditions, and more and more research has been carried out on its application. However, when conventional surface air coolers are directly used under high temperature and high humidity conditions (the temperature is higher than 30°C, both the humidity ratios are higher than 20 g/kg dry air), or under conditions with strict dehumidification requirements, the expected results are often not achieved. Therefore, taking the conventional surface cooler as an example, the performance and efficiency of dehumidification of the surface cooler under high temperature and high humidity are investigated specifically in this paper. Based on the above model and experiment, the influence of operation parameters on heat and mass transfer of surface air cooler is analyzed. At the same time, the change law of heat and mass transfer capacity, dehumidification performance, and heat transfer efficiency of a surface air cooler is specially investigated. Results proved that under high temperature and humidity conditions (34.8°C, 23.03 g/kg dry air), lower head-on wind velocity could realize deeper humidification effects effectively, while water velocity showed fewer impacts. As shown in the experiment, when water velocity increased to 1.2 m/s, and head-on wind velocity dropped to 1.06 m/s, the humidity ratio at the air outlet reduced to 8.88 g/kg while heat-transfer efficiency reached 0.778; however, when head-on velocity increased to 2.5 m/s and water velocity rose to 1.2 m/s, humidity ratio at air outlet dropped to 13.17 g/kg only, and heat-transfer efficiency reached merely 0.572. In conclusion, this paper has established an accurate and effective mathematical model for analyzing the heat transfer and dehumidification characteristics of the surface cooler under high temperature and high humidity conditions, which provides a reference for the development and design of dehumidification surface cooler under special conditions. More importantly, the conclusion of this paper also points out that, different from the adjusting strategy under conventional working conditions, reducing the head-on wind speed is the best adjusting strategy when the air surface cooler is used in high temperature and high humidity working conditions. This adjusting strategy is not only conducive to promoting the air to achieve a better dehumidification effect but also can effectively improve the efficiency of the surface cooler.

## 1. Introduction

As a kind of efficient and low-cost heat-transfer device, surface air coolers are highly popular in air-conditioning, dehumidifying, and chemical applications.

Current conventional surface air coolers are usually designed for nominal conditions (the dry bulb temperature is 27°C, and the wet bulb temperature is 19.5°C), wind speed 2.5 m/s, and inlet and outlet water temperature 7°C/12°C [1]. For the purpose of improving the heat transfer performance of surface air coolers to make them satisfy dehumidification

requirements, researchers increase pipe banks and enlarge heat transfer area. Mei et al. [2] established a mathematical model of a cooling coil and carried out a simulation study on the law of changes in the heat transfer capacity and dehumidifying system of surface air cooler under different conditions such as changing only the chilled water flow and changing only the air volume, etc., and finally put forward with a method for systematic energy conservation and optimization, that is, to adjust the chilled water flow and the air volume simultaneously. Liu et al. [3] concluded, with the control variable method, that the heat-transfer efficiency of

surface air cooler would increase along with the increase of water velocity and decrease along with the increase of the head-on wind velocity and the dehumidifying coefficient. Li [4] proposed, for the high temperature and high humidity conditions, to realize dehumidification by adopting the two-level rotary dehumidifying plus direct evaporative cooling system. You et al. [5] analyzed, based on experiments, whether indirect evaporative cooling and energy-recovering system used in high temperature and humidity area can satisfy dehumidification requirements.

The abovementioned literature researches show that there are few studies on the dehumidification performance and efficiency of conventional surface air coolers under high temperature and humidity conditions. However, high temperature and humidity conditions are common in many applications, such as the air-conditioning system in the summer, especially in the plum rain season, in regions south of the Yangtze River [6], the solar-energy-based wastewater treatment system in the chemical industry [7], the air-conditioning system in textile workshops [8], and other related industrial applications. In engineering applications, when a regular surface air cooler is used under high temperature and humidity conditions (the temperature is higher than 30°C, both the humidity ratios are higher than 20 g/kg dry air), defects such as failure to reach dehumidification requirements appear frequently, resulting in the cumulation of humidity road. Moreover, surface air coolers today generally focus on heat transfer but ignore dehumidification, which results in the common existence of poor heat-transfer efficiency when such surface air coolers are used for dehumidifying [9]. To meet the dehumidification requirements, namely, the requirements for high mass transfer, when using a regular surface air cooler to treat air at high temperature and humidity, it is necessary to reform and optimize such surface air cooler. At present, there are two optimization methods: (1) to adjust the operating conditions of the surface air cooler, and (2) to change the structure of the conventional surface air cooler. Among them, the second method would increase the cost of equipment investment, resulting in low economic benefits. Therefore, the first method is more suitable.

In order to solve the above problems, in this paper, based on the conventional surface cooler structure, from the perspective of changing the operating conditions, the heat and mass transfer model of the surface cooler is established, and the corresponding experimental platform is also set up. The dehumidification performance and efficiency of the surface cooler under the condition of high temperature and high humidity are analyzed by means of both simulation and experiment. This paper aims to explore the heat and mass transfer law of surface coolers under high temperature and high humidity conditions through experiment and simulation and find an effective method to solve the poor dehumidification effect under this special condition, to provide reference for further research and design of surface cooler.

## 2. Modeling

**2.1. Physical Model.** First of all, assumptions for the establishment of a physical model were given based on the actual situation of regular surface air cooler [10]:

- (1) The surface air cooler is made of a regular finned-pipe structure, with the air and the water flow in a cross direction;
- (2) Condensate water generated in the heat-transfer process flows away in time from the coil surface, thus impacts from the cumulation of such condensate water in finned-pipe gaps are ignored;
- (3) Contact thermal resistance and fouling resistance are ignored;

Based on such assumptions, a physical model of a finned-pipe surface air cooler is established. Figure 1(a) shows the structure of the such model, while Figure 1(b) shows the internal structure of finned pipes.

**2.2. Mathematical Model.** A mathematical model of the heat and mass transfer process of the surface air cooler was established based on the physical model described above.

### 2.2.1. Heat-Transfer Model at Pipe Outer Side of Surface Air Cooler

- (1) Energy-balance equation:

$$\begin{aligned} Q_1 &= q_{am}(i_{a,in} - i_{a,out}) - m_{cw}i_{cw}, \\ Q_1 &= h_s \times A_{out} \times \Delta t_{out}. \end{aligned} \quad (1)$$

Mass-balance equation:

$$m_{cw} = q_{am}(d_{a,in} - d_{a,out}), \quad (2)$$

in which  $Q_1$  is the heat transfer capacity kW between air at the outer pipe side and the outer pipe wall;

$q_{am}$  is the mass flow of the air (kg/h);

$i_{a,in}$ ,  $i_{a,out}$  are the enthalpy at the air inlet and outlet (kJ/kg);

$d_{a,in}$ ,  $d_{a,out}$  is the moisture content at air inlet and outlet (kg/kg);

$m_{cw}$  is the mass flow of the condensate water, namely, the dehumidification capacity (kg/h);

$i_{cw}$  is the enthalpy of condensate water (kJ/kg.dry);

$h_s$  is the heat transfer coefficient at outer pipe side under wet conditions ( $W/m^2 \cdot K$ );

$A_{out}$  is the heat transfer area out of the pipe ( $m^2$ );

$\Delta t_{out}$  is the heat transfer temperature difference out of the pipe, °C.

It should be noted here that when air is cooled and dehumidified by the surface cooler, heat transfer and mass transfer are carried out together. Therefore, the part of energy taken away by condensate water also needs to be included in the energy balance equation.

- (2) Heat transfer equation:

The heat transfer factor  $j_1$  proposed by Colburn [11] is used to calculate the heat transfer process. The mathematical model is expressed as follows:

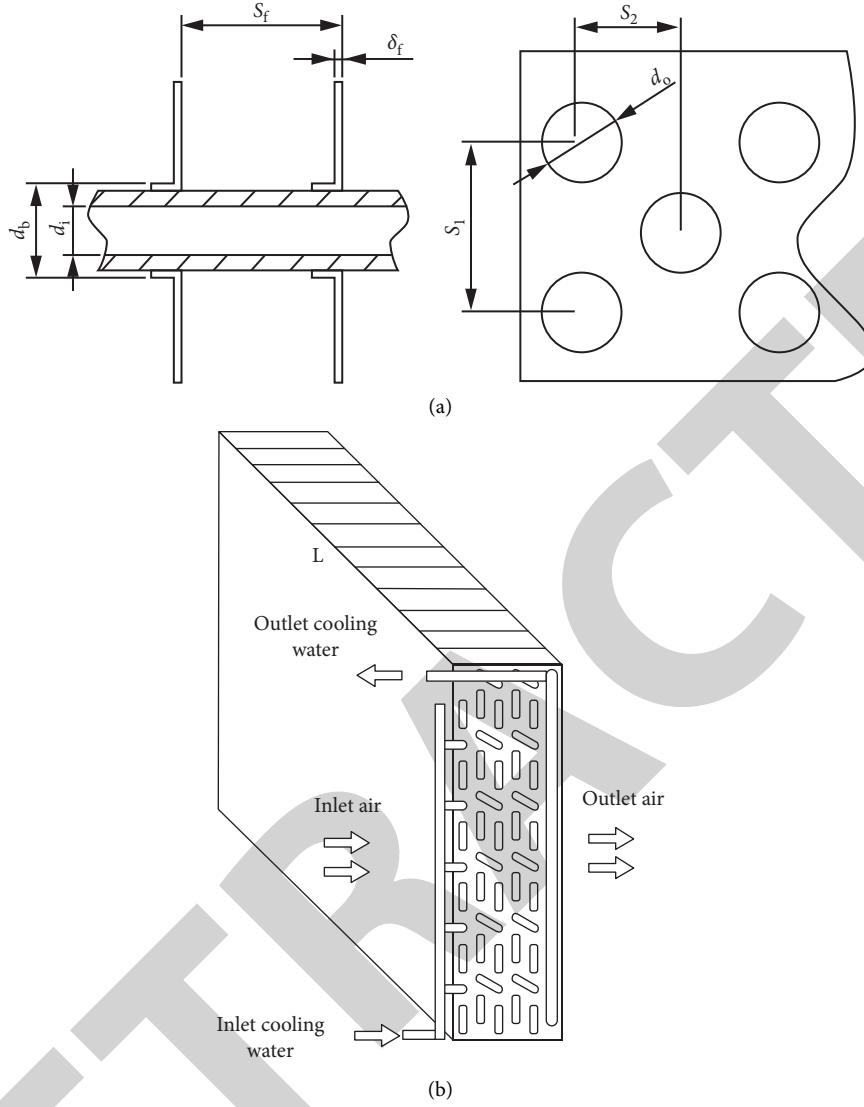

FIGURE 1: Structure diagrams of surface air cooler (a, b).

$$j_1 = \frac{h_1 A_y}{q_{ma} C_{pa}} Pr^{2/3},$$

$$j_1 = \left[ \frac{1 - 1280 \times N \times Re_L^{-1.2}}{1 - 5120 \times Re_L^{-1.2}} \right] \times (0.0014 + 0.2618 J_p), \quad (3)$$

$$J_p = Re_D^{-0.4} \left[ \frac{A_o}{A_{b_o}} \right]^{-0.15},$$

in which  $Re_L$  is the Reynolds number based on vertical pipe spacing;

$Re_D$  is the Reynolds number based on the outer diameter of the pipe;

$h_1$  is the heat transfer coefficient at outer pipe side under dry conditions,  $W/m^2 \cdot K$ ;

$A_y$  is the head-on wind area,  $m^2$ ;

$N$  is the number of pipe banks;

$C_{pa}$  is the specific heat of the wet air,  $kJ/kg \cdot K$ .

The model above is a heat transfer model under dry conditions. Because the finned tube surface air cooler works under wet conditions, it is necessary to modify its heat transfer coefficient. Under wet conditions, the heat transfer coefficient  $h_s$  is as follows:

$$h_s = h_1 \times \zeta \times \eta_{ao}, \quad (4)$$

where  $\eta_{ao}$  is the efficiency of the finned surface, expressed as follows:

$$\eta_{ao} = \frac{\eta_f \times A_f + A_b}{A_o}, \quad (5)$$

Here,  $A_f$  is the side face area of the fin,  $m^2$ ;

$A_b$  is the interfins pipe surface area,  $m^2$ ;

$A_o$  is the total side face area of fins,  $m^2$ ;

$\eta_f$  is the fin efficiency of the surface air cooler, namely, the contact coefficient [12].

$$\eta_f = \frac{\text{th}(mh)}{mh},$$

$$m = \sqrt{\frac{2h_1}{\lambda_l \delta_f}},$$
(6)

in which  $h$ — is the equivalent fin height,  $m$ ;  
 $\lambda_l$  is the heat conductivity coefficient of aluminum,  $W/m \cdot k$ ;

$\delta_f$  is the fin thickness,  $m$ ;

In equation (4),  $\zeta$  is the dehumidifying coefficient of modified dry conditions [13]:

$$\zeta = 1 + \left[ \frac{r_w + t_{a,m} \times C_{pw} - t_{wa,out} \times C_w}{c_{pa}} \right]$$

$$\times \frac{(d_{a,m} - d_{a,wa})}{(t_{a,m} - t_{wa,out})},$$
(7)

in which  $r_w$  is the latent heat of evaporation of the water;

$t_{a,m}$  is the mean temperature of the air, °C;

$t_{wa, out}$  is the temperature of the outer wall of the pipe, °C;

$d_{a,m}$  is the moisture content of air at  $t_{a,m}$ , kg/kg;

$d_{a,wa}$  is the moisture content of air at  $t_{wa, out}$ , kg/kg;

$C_{pw}$  is the specific heat of water vapor,  $kJ/kg \cdot k$ ;

$C_w$  is the specific heat of water,  $kJ/kg \cdot k$ .

### 2.2.2. Heat Transfer Model at Internal Side of Surface Air Cooler

(1) Energy-balance equation:

$$Q_2 = C_w q_{mw} (t_{w,out} - t_{w,in}),$$

$$Q_2 = h_n \times A_{in} \times \Delta t_{in},$$
(8)

in which  $Q_2$  is the heat transfer capacity at the internal side of the pipe, kW;

$q_{mw}$  is the mass flow rate of water, kg/h;

$t_{w,in}$ ,  $t_{w,out}$  are the inlet and outlet water temperatures, °C;

$h_n$  is the heat transfer coefficient inside the pipe,  $W/m^2 \cdot k$ ;

$A_{in}$  is the heat transfer area inside the pipe,  $m^2$ ;

$\Delta t_{in}$  is the heat transfer temperature difference inside the pipe, °C.

(2) Heat transfer model:

For the heat transfer coefficient  $h_n$  inside the pipe, Gnielinski [14] formula is employed for solution as follows:

$$V_f = \left\{ \frac{f}{8} \times (Re_w - 1000) \times \left[ \frac{Pr_f}{1 + 12.7(f/8)^{1/2} \times (Pr_f^{2/3} - 1)} \right] \right.$$

$$\left. \times \left( 1 + \frac{d_o}{L} \right)^{2/3} \right\} \times c_t,$$

$$V_f = h_n \frac{d_i^2}{\lambda_{s1}},$$
(9)

$$f = \frac{1}{(1.82 \times \log(Re_w) - 1.64)^2},$$

$$c_t = \left( \frac{Pr_f}{Pr_w} \right)^{0.01},$$

in which  $Pr_f$  is the Prandtl number of the water at mean temperature;

$Pr_w$  is the Prandtl number of the water at interior wall temperature of the pipe;

$Re_s$  is the Reynolds number of the water at mean temperature;

### 2.2.3. Heat Transfer Model at Wall Face of the Surface Air Cooler

(1) Heat transfer equation [15]:

$$Q_3 = N_1 \times N \times 2 \times \pi \times \lambda_c \times L_1 \times \left[ \frac{t_{wa,out} - t_{wa,in}}{\ln(d_o/d_i) \times 1000} \right],$$
(10)

where  $t_{w,in}$  is the temperature at the interior wall of the pipe, °C;

$N_1$  is the number of pipe arrays;

$\lambda_c$  is the heat transfer coefficient of copper,  $W/m \cdot k$ ;

$L_1$  is the total length of heat-transfer copper pipe,  $m$ .

(2) Energy-balance equation:

$$Q_3 = Q_1. \quad (11)$$

The interior wall temperature of the pipe,  $t_{wa,in}$  is calculated with the equation above, as criteria for model iteration.

2.2.4. Performance Parameter Model of the Surface Air Cooler. For the purpose of analyzing the heat and mass transfer capacity, dehumidifying performance, and heat transfer efficiency of the surface air cooler, the model outputs state parameters at the air outlet, heat transfer capacity  $Q$ , dehumidification capacity  $m_{cw}$ , heat transfer coefficient  $K$ , contact coefficient  $\eta_f$ , heat exchanger efficiency  $\eta_{ao}$ , and specific air consumption SAC [16].

Heat transfer coefficient  $K$ :

$$K = \frac{Q}{\Delta t \cdot A}. \quad (12)$$

Here,  $\Delta t$  is the heat transfer temperature difference of surface air cooler, and  $^{\circ}\text{C}$ ;  $A$  is the heat transfer area of surface air cooler,  $\text{m}^2$ .

Heat exchanger efficiency  $\eta_{ao}$  :

$$\eta_{ao} = \frac{t_{a,in} - t_{a,out}}{t_{a,in} - t_{w,in}} \quad (13)$$

Specific air consumption refers to the amount of air consumed per unit of dehumidification. It can reflect the power consumption of the blower from the side. Generally, the higher the specific air consumption is, the higher the power consumption of the blower will be.

$$\text{SAC} = \frac{q_{ma}}{m_{cw}} \quad (14)$$

**2.3. Logic Block Diagram of the Model.** The mathematical model above consists of four major modules and multiple boundary conditions. Software EES was used for code editing, and a complete heat and mass transfer model of the finned-pipe surface air cooler was established for systematic stimulation research. See Figure 2 for the model calculation logic diagram.

### 3. Surface Air Cooler Experiment

**3.1. Establishment of the Testbed and Layout of Test Points.** In order to verify the accuracy of the model and examine the actual influence of the changes in system operating parameters, an experimental bench as shown in Figure 3 is built. The setting and regulation of the working conditions are realized by using the enthalpy difference laboratory, as shown in Figure 4.

All experimental operating parameters, including air inlet and outlet dry and wet bulb temperatures, pressure difference before and after the nozzle, inlet and outlet water temperature, and water flow rate, can be displayed and set through the terminal control platform of the enthalpy difference laboratory, as shown in Figure 5.

**3.2. Test Conditions.** To simulate engineering applications, high temperature and humidity fresh air condition in the summer of Nanjing were taken as inlet air parameters for simulation and experimental analysis, see Table 1 for experimental test condition.

#### 3.3. Experimental Data Processing and Error Analysis

**3.3.1. Data Processing.** In the experiment, primary measured parameters ( $t_{a,in}$ ,  $t_{sa,in}$ ,  $t_{a,out}$ , and  $t_{sa,out}$ ) can be obtained directly by measurement, while indirect parameters ( $\eta_{ao}$ ,  $k$ , and SAC) of surface air cooler can be obtained from a calculation based on equations (1)~(14).

**3.3.2. Error Analysis.** Experimental errors include instrument errors and indirect errors.

(1) Instrument errors are shown in Table 2.

(2) Indirect error:

According to the method proposed by Moffat [17], measuring uncertainties are defined as different square roots between observed solid errors and random errors of the instrument. As for the experiment described herein, directly measured uncertainties are deemed as independent from each other, uncertainties of indirect parameters, thus can be calculated as follows:

$$u_c = \sqrt{\sum_{i=1}^N \left( \frac{\partial f}{\partial x_i} \right)^2 (u_{xi})^2} \quad (15)$$

Here,  $x$  is the directly measured parameter,  $f$  refers to the relationship between the indirectly measured parameter and directly measured parameter, and  $u_x$  is the direct measurement error. According to the abovementioned method, errors of all indirect parameters are  $\pm 5\%$ , which proves the reliability of the test under the experiment.

## 4. Results and Discussion

**4.1. Experimental Verification of the Model.** This paper conducted a comparison study between experimental results and stimulated results so that to verify the accuracy of the heat transfer model of the surface air cooler established herein.

Figure 6 shows the comparison between the experimental results and stimulated results of the outlet air dry bulb temperature, the air outlet moisture content, and the outlet water temperature. It can be clearly seen that the prediction accuracy of the model for these three state parameters is very high, and the error is within  $\pm 10\%$ . Therefore, the model of finned-pipe surface air cooler established in this paper is reliable. Subsequently, the dehumidification performance and efficiency of surface air coolers under high temperature and humidity conditions are analyzed in detail by combining simulation and experiment.

**4.2. Analysis on Affecting Factors.** This paper studied mainly the impacts of operating conditions on the dehumidification performance and efficiency of surface air coolers. Affecting parameters include mainly water flow velocity and head-on wind velocity.

As shown in Figure 7, when the water flow velocity is unchanged, both the temperature and moisture content of the air outlet dry bulb drop gradually along with the drop of head-on wind velocity. In the contrast, when head-on wind velocity is unchanged, both the temperature and moisture content of the air outlet dry bulb increase gradually along with the drop of water flow velocity.

By comparing the effects of changes in water flow velocity and changes in head-on wind velocity, we know the effects of these two factors on the temperature and moisture content of the air outlet dry bulb are opposite to each other. Thus, preliminarily, reducing the head-on wind velocity or

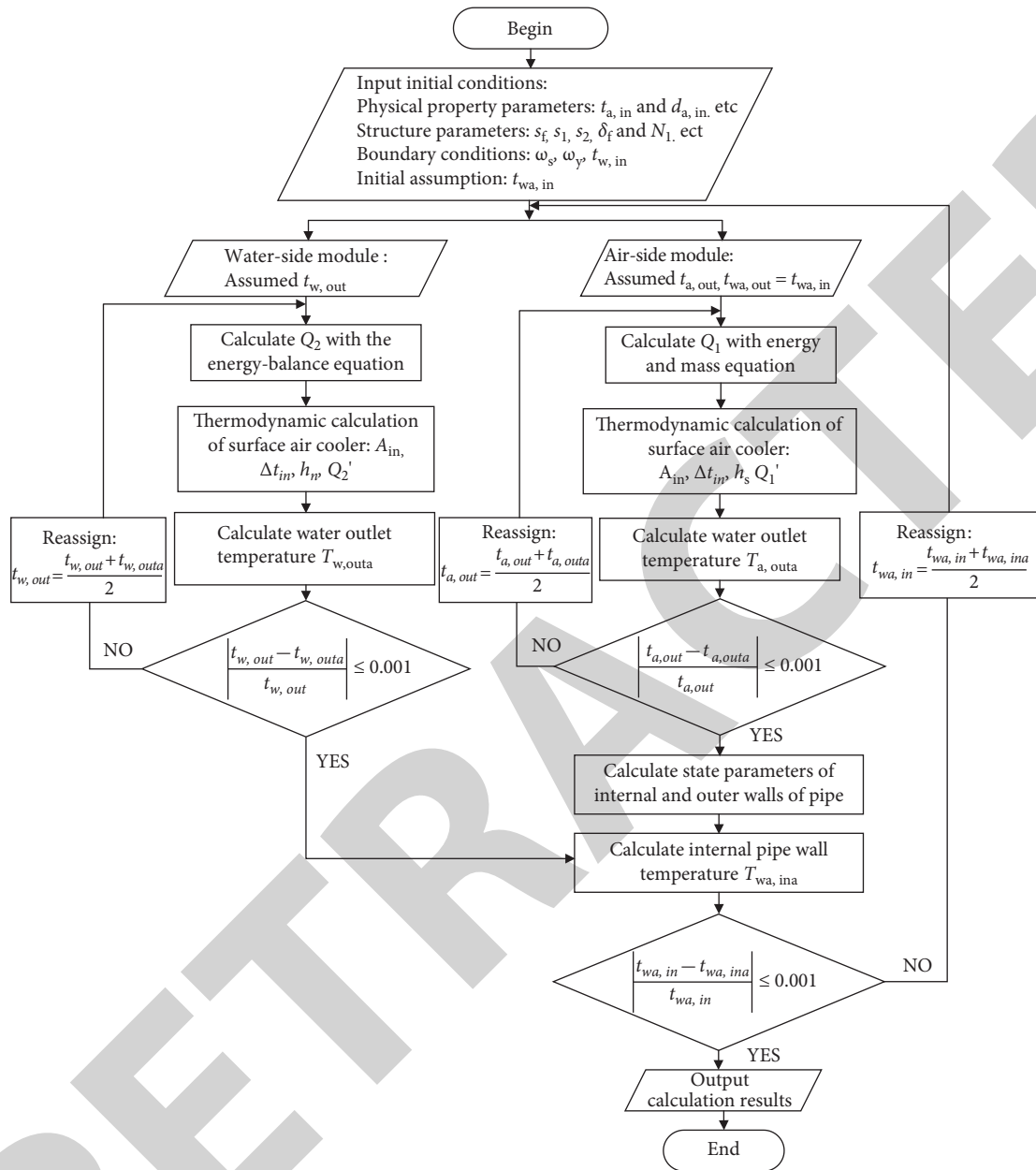

FIGURE 2: Model calculation logic diagram.

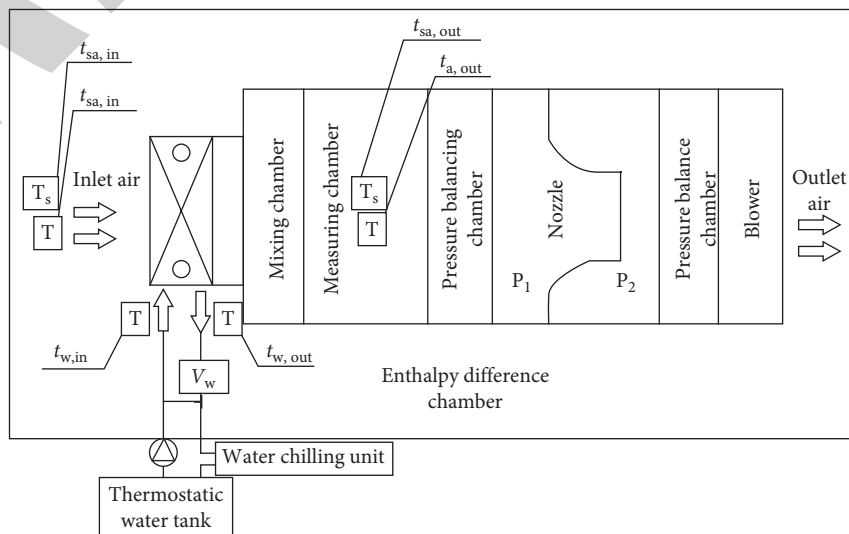

FIGURE 3: Test point layout of the experimental system.

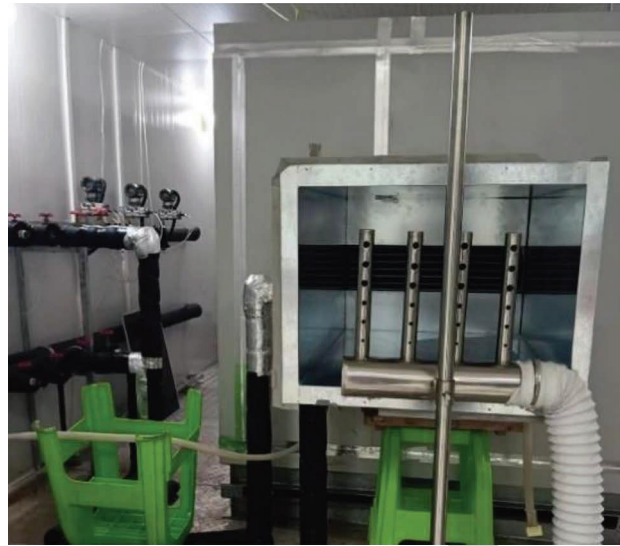

FIGURE 4: Physical photo of the experimental system.

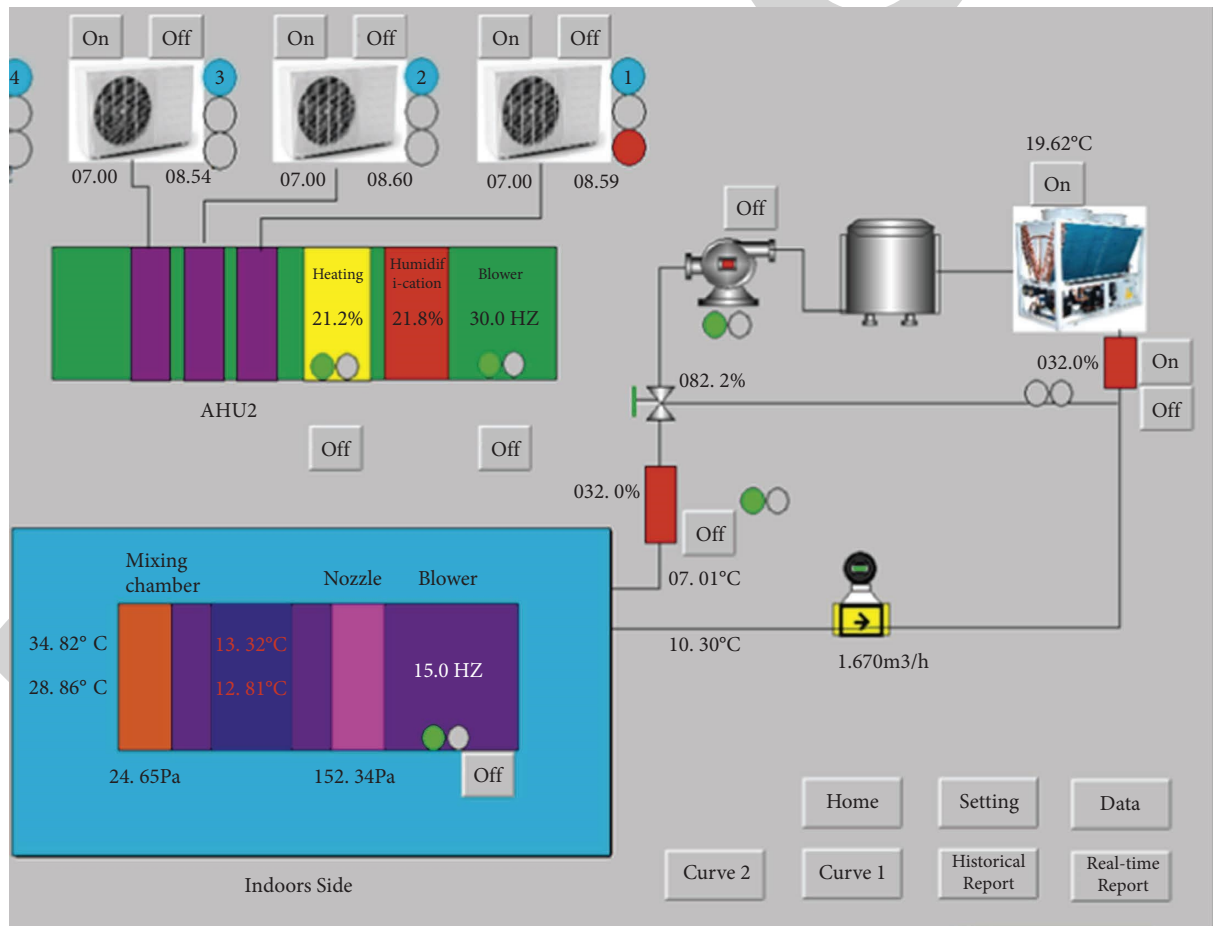

FIGURE 5: Control principle of the experimental system.

improving the water flow velocity can both reduce effectively the temperature and moisture content of the air outlet dry bulb and realize lower moisture content at the outlet of the

finned-pipe surface air cooler under high temperature and humidity condition, namely, realizing deep dehumidification effects.



TABLE 1: Experimental test condition.

Parameters	Value
$t_{a,in}/^{\circ}\text{C}$	34.8
$t_{sa,in}/^{\circ}\text{C}$	28.9
$\omega_y/m/s$	0.5~3
$\omega_w/m/s$	0.5~1.2
$t_{w,in}/^{\circ}\text{C}$	7

TABLE 2: Measuring parameters and instruments.

Measuring parameters	Instruments	Model	Precision	Measuring range
Temperature	Pt100 platinum thermistor	WZP-02	Level A	-200~420 $^{\circ}\text{C}$
Water flow rate	Electromagnetic flowmeter	AXF040G	$\pm 0.35\%$ $\text{m}^3/\text{h}$	0~70 $\text{m}^3/\text{h}$
Air flow rate	Differential pressure gauge	EJA110A	$\pm 0.25\%$ FS	0~1000 Pa

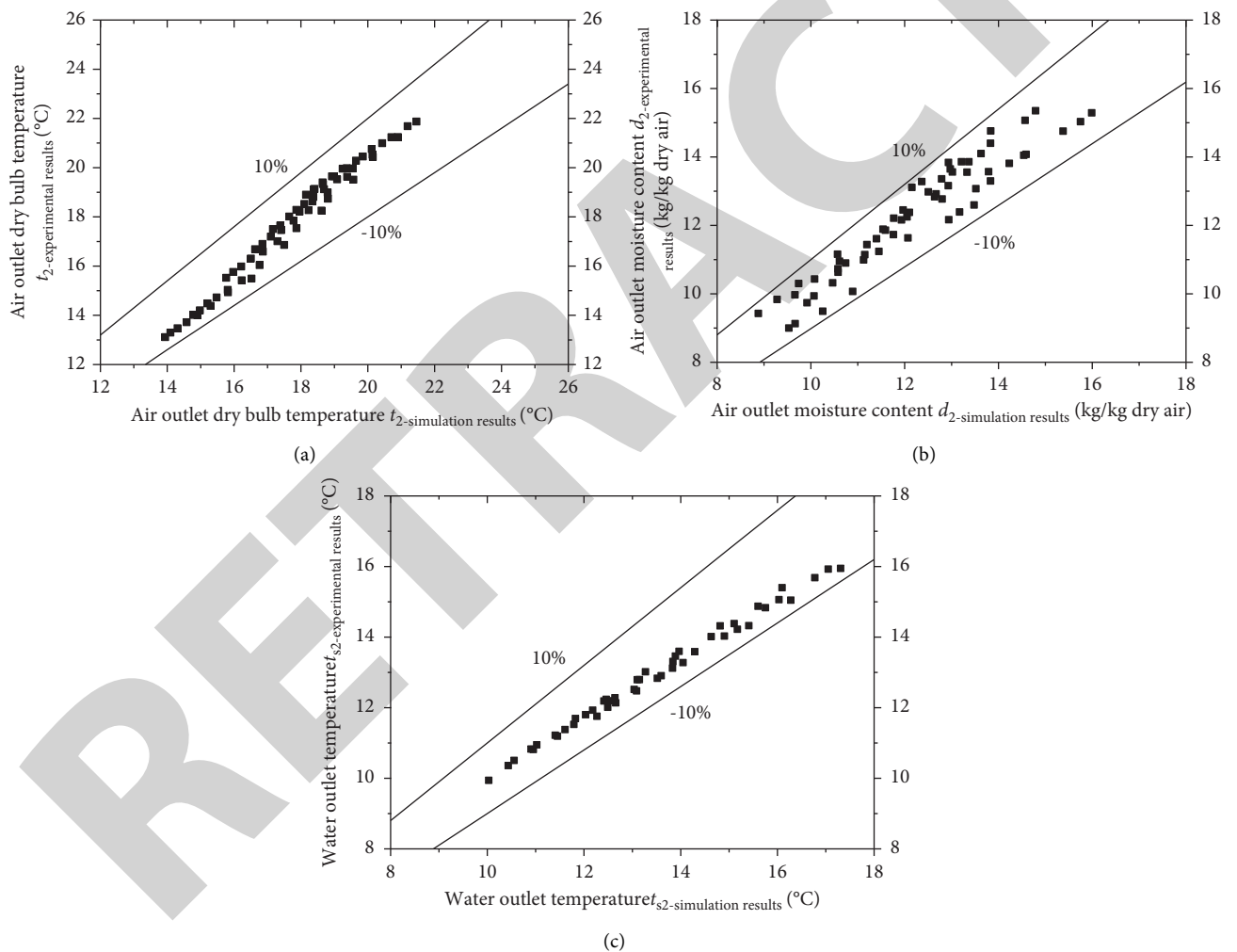

FIGURE 6: Comparison between experimental results and simulation results.

When the water flow velocity was kept at 1.2 m/s and the head-on wind velocity dropped from 3 m/s to 0.5 m/s, the temperature of the air outlet dry bulb dropped from 15.49 $^{\circ}\text{C}$  to 13.11 $^{\circ}\text{C}$ , while the air humidity ratio dropped from 10.57 g/kg to 8.88 g/kg, dropped by 16%. Moreover, increasing the water flow velocity will consume more power from the water pump. In consequence, reducing the head-on wind

flow velocity increased from 0.5 m/s to 1.2 m/s, the temperature of the air outlet dry bulb dropped from 15.49 $^{\circ}\text{C}$  to 13.11 $^{\circ}\text{C}$ , while the air humidity ratio dropped from 10.57 g/kg to 8.88 g/kg, dropped by 16%. Moreover, increasing the water flow velocity will consume more power from the water pump. In consequence, reducing the head-on wind

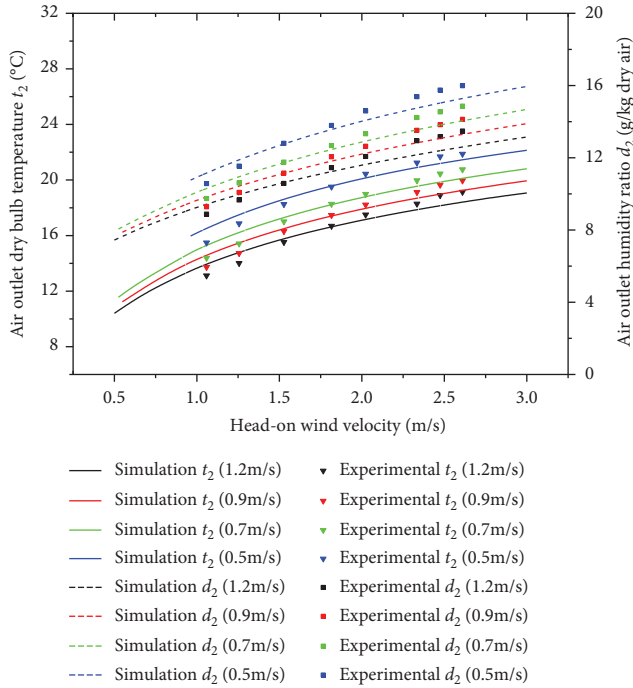

FIGURE 7: Effects of the head-on wind velocity and water flow velocity to air outlet parameters.

velocity shows more advantages in heat transfer and dehumidification.

The above analysis focuses on the influence of state parameters that explain the overall heat transfer and dehumidification effects of the surface air cooler. In addition, it is equally important to analyze the performance parameters. As shown by curves in Figure 8, when the water flow velocity was the same, the heat coefficient dropped gradually while the contact coefficient increased gradually, along with the reduction of head-on wind velocity; when the head-on wind velocity was the same, heat transfer coefficient decreased gradually while contact coefficient increased gradually along with the reduction of water flow velocity. In terms of overall effects, reducing the head-on wind velocity or water flow velocity goes against the increase of the heat transfer coefficient but helps increase the contact coefficient. Therefore, changing condition parameters could not prove whether the surface air cooler is good or not in heat transferring or dehumidifying. Moreover, this paper studied mainly the dehumidification performance of surface air coolers under high temperature and humidity conditions, which makes the mere considering of heat transfer coefficient one-sided relatively.

As shown in Figure 9, when the water flow velocity kept the same, the reduction of head-on wind velocity made the heat transfer efficiency improve significantly and SAC dropped gradually; when the head-on wind velocity kept the same, the increase of water flow velocity made the heat transfer efficiency and SAC improved slightly.

According to the above analysis, reducing the head-on wind velocity could not only realize the dehumidification effects but also improve effectively the heat transfer

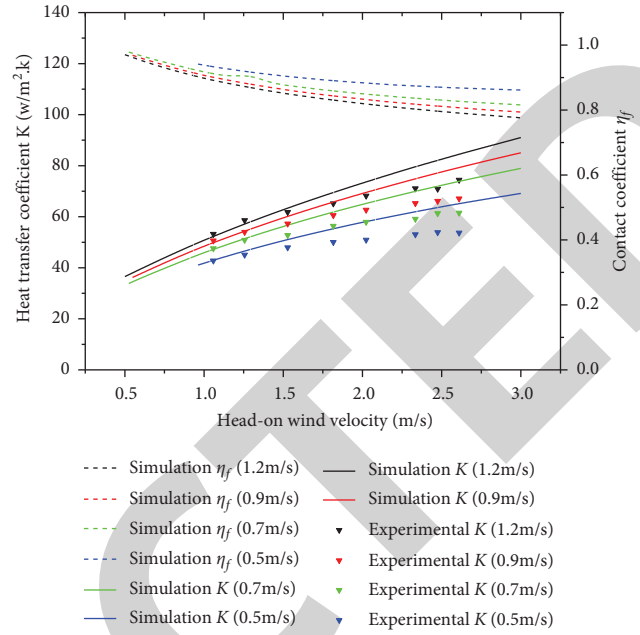

FIGURE 8: Effects of the head-on wind velocity and water flow velocity to heat transfer performance.

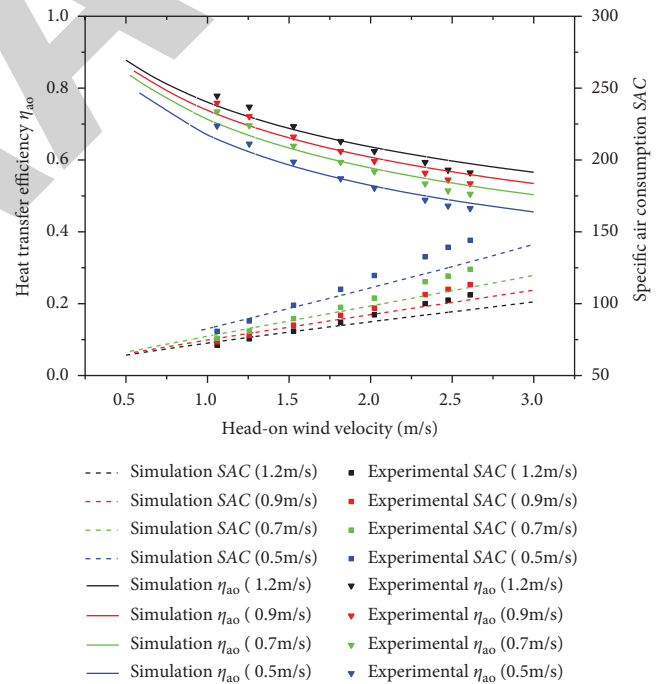

FIGURE 9: Effects of the head-on wind velocity and water flow velocity to heat transfer efficiency.

efficiency of surface air cooler and make the overall dehumidification and heat transfer process closer to the theoretical limit (for example, when the head-on wind velocity decreased from 2.5 m/s under standard working condition of regular surface air cooler to 1.06 m/s under conditions described in the experiment herein,  $\eta_{ao}$  increased by 36% and SAC decreased by 30.5%). Moreover, reducing the head-on wind velocity could reduce SAC,

TABLE 3: Comparison of surface coolers in different applications.

Types of surface cooler application	The head-on wind speed (m/s)	Air humidity ratio after dehumidification by surface cooler (g/kg dry air)	The heat exchanger efficiency of the cooler $\eta_{ao}$
Surface cooler for chiller units used in conventional air-conditioning [3]	1.8	9.5	0.694
Surface cooler for evaporative chiller units used in hot and humid areas [5]	1.8	12.7	0.617
Surface cooler for dehumidifying high temperature and high humidity air in wastewater recovery treatment [16]	2.0	16.44	0.525
Surface air cooler in this paper	1.8	12.68	0.621
	0.5	7.45	0.867

and the reduction of SAC means lower airflow of surface air cooler under the same dehumidification requirements, which is beneficial to reduce energy at the air-delivery side, that is, to reduce the power consumption of the blower. Although increasing the water flow velocity could slightly promote the dehumidification and heat transfer effects and performance, such an increase resulted in higher power consumption of the water pump. Therefore, from the perspective of working condition regulation, significantly reducing the head-on wind speed is more conducive to improving the dehumidification effect of surface air coolers under high temperature and humidity conditions and reducing energy consumption.

#### 4.3. Comparison and Analysis with Current Surface Coolers.

As shown in Table 3, the final dehumidification effect of the surface cooler and the comparison of heat exchanger efficiency under different application conditions are shown. When applied to conventional working conditions, it is obvious that the surface air cooler can have both a better dehumidification effect (keeping the air humidity ratio below 10 g/kg dry air) and good heat exchanger efficiency (about 0.7) at a higher head-on wind speed. However, when the surface cooler is used in high temperature and high humidity conditions, continuing to choose the same head-on wind speed as in the conventional conditions can no longer meet better dehumidification and high efficiency, just as shown in the literature [5] and literature [16]. The research results in this paper also show that at a higher head-on wind speed (1.8 m/s), the humidity ratio of the outlet air of the surface cooler is also maintained at 12.68 g/kg dry air, and the heat exchanger efficiency is also lower (only 0.621). However, another analysis result of this paper also shows that in conditions of high temperature and humidity, the air humidity ratio after dehumidification by surface cooler can be effectively reduced by reducing the head-on wind speed, thus achieving a better dehumidification effect. At the same time, high heat exchanger efficiency can be maintained (0.867).

Therefore, by comparing with the application of existing surface coolers, it can also be concluded that reducing the head-on wind speed has a good improvement effect on the problems of poor treatment effect and low efficiency of the heat exchanger when the surface cooler is treating high temperature and high humidity air.

## 5. Conclusion

In this paper, the performance and efficiency of the surface cooler are investigated in detail under high temperature and high humidity conditions. By establishing the heat and mass transfer model of the surface cooler and combining it with the performance test of the surface cooler, the simulation and experimental test of the surface cooler are carried out. The influence of working condition parameters on the dehumidification performance of surface coolers under high temperature and high humidity conditions is mainly explored, and the following conclusions are reached:

- (1) The heat and mass transfer model established in this paper has high accuracy (the error of predicting air temperature and humidity can be maintained within  $\pm 5\%$ ). Therefore, this model can provide a reference for the subsequent optimization design of surface coolers used in extreme working conditions such as high temperature and high humidity air treatment.
- (2) Factor analysis shows that the impact of the head-on wind speed on the heat transfer and dehumidification performance of the surface cooler is greater than that of the water velocity. Therefore, in engineering applications, it is more beneficial to improve the energy efficiency of the system by regulating the head-on wind speed to meet the actual dehumidification demand.
- (3) Performance analysis shows that, compared with the conventional working conditions, when the surface cooler with the same design parameters is used in high temperature and high humidity working conditions, the dehumidification effect of the surface cooler and the heat exchanger efficiency will be significantly reduced. Under this condition, the design changes of the heat exchanger to reduce the head-on wind speed can effectively improve the dehumidification effect, improve the heat exchanger efficiency, and reduce the gas consumption ratio to reduce the power consumption.

The conclusion of this paper enriches the research of surface coolers under extreme conditions of high temperature and humidity and has reference significance for the development and design of surface coolers under such conditions. However, this paper only investigated the performance and efficiency of the surface cooler. In the future,

the dehumidification performance of the surface cooler structure optimization will be further studied by using the model established in this paper and the proposed experimental methods.

### Data Availability

The data used to support the findings of this study are included in the article.

### Conflicts of Interest

The authors declare that they have no conflicts of interest.

### Acknowledgments

This work was supported by the General Project of Natural Science Research of Jiangsu Higher Education Institutions of China (no. 21KJB480016) and the Jiangsu Vocational Institute of Commerce Startup Fund for Ph.D. Talents (no. 1042141223029).

### References

- [1] *Air Cooling and Air Heating Coils: GB/T 14296-2008*, Standardization Administration of the China, Beijing, China, 2008.
- [2] K. Mei, C. H. Liang, and X. S. Zhang, "Influence of variable-volume on performance of cooling coil," *Journal of Chemical Industry and Engineering*, vol. 59, no. S32, pp. 109–132, 2008.
- [3] X. J. Liu, K. Liu, and C. H. Liu, "The heat transfer efficiency analysis of surface air cooler," *Henan Science*, vol. 32, no. 7, pp. 1266–1268, 2014.
- [4] L. Li, *Study on the Performance of Temperature and Humidity Independent Treatment Device in High Temperature and High Humid Area*, Xi'an University of Architecture and Technology, Xi'an, China, 2018.
- [5] Y. You, J. Jiang, and C. Guo, "Application and analysis of indirect evaporative cooling air conditioning unit in hot and humid areas," *Fluid Machinery*, vol. 47, no. 8, pp. 71–75, 2019.
- [6] Y. Zhang, *The Adaptability Research on the Combined Use of Dedicated Outdoor Air Ventilation and Dry Cooling Air-Conditioning System Used for Hot and Humid Regions*, Tianjin University of Commerce, Tianjin, China, 2012.
- [7] C. Chen, S. M. Jin, and L. Chen, "Experimental investigation of spray separation tower in air circulation evaporation separation system for electroplating wastewater," *Fluid Machinery*, vol. 49, no. 8, pp. 1–6, 2021.
- [8] X. C. Ruan, *Application of Temperature and Humidity Independent Control in the High Temperature and High Humidity Workshop*, Zhongyuan University of Technology, Zhengzhou, China, 2015.
- [9] Z. W. Lian, *Heat and Mass Transfer Fundamentals and Equipment*, China Architecture & Building Press, Beijing, China, 2011.
- [10] E. Z. Zhang and Y. T. Chi, "Numerical simulation of the thermal performance of surface air cooler," *Energy Resource and Information*, vol. 17, no. 4, pp. 232–238, 2001.
- [11] W. Z. Gu, *Heat Transfer Enhancement*, Science Press, Beijing, China, 1990.
- [12] Y. Z. Wu, *Small Refrigeration Units Design Guide*, China Machine Press, Beijing, China, 1998.
- [13] Y. Z. Wu, *Principles and Equipment of Refrigeration*, Xi'an Jiaotong University Press, Xi'an, China, 1997.
- [14] V. Gnielinski, "New equations for heat and mass transfer in turbulent pipe and channel flow," *International Chemical Engineering*, vol. 16, 1976.
- [15] S. M. Yang and W. Q. Tao, *Heat Transfer*, High Education Press, Beijing, China, 2001.
- [16] J. Yu, L. Chen, and W. Yan, "Experimental and simulation investigation on the characteristics and performance of the spray separation tower for evaporation crystallization of saline wastewater," *Desalination and Water Treatment*, vol. 232, pp. 67–90, 2021.
- [17] R. J. Moffat, "Describing the uncertainties in experimental Results," *Experimental Thermal and Fluid Science*, vol. 1, no. 1, pp. 3–17, 1988.