

## *Retraction*

# **Retracted: Low-Latency and High-Concurrency 5G Wireless Sensor Network Assists Innovation in Ideological and Political Education in Colleges and Universities**

### **Journal of Sensors**

Received 22 August 2023; Accepted 22 August 2023; Published 23 August 2023

Copyright © 2023 Journal of Sensors. This is an open access article distributed under the Creative Commons Attribution License, which permits unrestricted use, distribution, and reproduction in any medium, provided the original work is properly cited.

This article has been retracted by Hindawi following an investigation undertaken by the publisher [1]. This investigation has uncovered evidence of one or more of the following indicators of systematic manipulation of the publication process:

- (1) Discrepancies in scope
- (2) Discrepancies in the description of the research reported
- (3) Discrepancies between the availability of data and the research described
- (4) Inappropriate citations
- (5) Incoherent, meaningless and/or irrelevant content included in the article
- (6) Peer-review manipulation

The presence of these indicators undermines our confidence in the integrity of the article's content and we cannot, therefore, vouch for its reliability. Please note that this notice is intended solely to alert readers that the content of this article is unreliable. We have not investigated whether authors were aware of or involved in the systematic manipulation of the publication process.

Wiley and Hindawi regrets that the usual quality checks did not identify these issues before publication and have since put additional measures in place to safeguard research integrity.

We wish to credit our own Research Integrity and Research Publishing teams and anonymous and named external researchers and research integrity experts for contributing to this investigation.

The corresponding author, as the representative of all authors, has been given the opportunity to register their agreement or disagreement to this retraction. We have kept a record of any response received.

### **References**

- [1] Y. Guo, "Low-Latency and High-Concurrency 5G Wireless Sensor Network Assists Innovation in Ideological and Political Education in Colleges and Universities," *Journal of Sensors*, vol. 2021, Article ID 9867800, 11 pages, 2021.

## Research Article

# Low-Latency and High-Concurrency 5G Wireless Sensor Network Assists Innovation in Ideological and Political Education in Colleges and Universities

Yuge Guo 

Department of Marxism, Zhengzhou Shengda University, Xinzheng 451191, China

Correspondence should be addressed to Yuge Guo; 100100@shengda.edu.cn

Received 17 September 2021; Accepted 12 October 2021; Published 8 November 2021

Academic Editor: Guolong Shi

Copyright © 2021 Yuge Guo. This is an open access article distributed under the Creative Commons Attribution License, which permits unrestricted use, distribution, and reproduction in any medium, provided the original work is properly cited.

This paper first analyzes the existing optimization models and methods based on low-latency and high-concurrency 5G wireless sensor networks and focuses on some research results based on the physical layer, data link layer, and network layer. After that, the energy-constrained cross-layer optimization algorithm of the joint physical layer and network layer and the cross-layer optimization algorithm based on reliable transmission are analyzed and compared. According to the ideological and political education cycle and network connectivity of wireless sensor networks, the existing definition of the ideological and political education cycle of wireless sensor networks was questioned and its irrationality was demonstrated. Firstly, we introduce the system model, energy capture model, and energy consumption model of this scheme; then, calculate the energy consumption of the node sending and receiving data and analyze the maximum throughput that the node can provide for data transmission to perform mathematical modeling. In a balanced ideological and political education cycle, the optimal solution is given. Finally, it introduces distributed high-throughput routing for EH-WSNs based on low latency and high concurrency and gives a performance comparison with the shortest path routing scheme. The energy consumption of each part of the node is analyzed in a comprehensive and in-depth manner, and the direction of the energy optimization strategy of the network node and its sensor network is pointed out. On this basis, this article proposes a new definition of the network ideological and political education cycle: the ideological and political education cycle of the wireless sensor network is equal to the ideological and political education cycle of the first joint in the network that fails due to energy exhaustion. Based on this definition, the wireless sensor network is analyzed, and the cross-layer (physical layer, data link layer, and network layer) optimization mathematical model of the wireless sensor network ideological and political education cycle is established. The two data collection schemes proposed in this paper are simulated under the conditions of no-delay ideological and political education cycle and different time-delayed ideological and political education cycles. The simulation results show that the model is better than both in terms of network life and data integrity.

## 1. Introduction

Sensor information acquisition technology has gradually developed from the simplification in the past to integration, miniaturization, and networking and has brought about an information revolution [1]. At the same time, the rapid development and improvement of wireless communication technology and digital signal processing have provided strong technical support for wireless communication networks based on information processing and transmission [2]. The wireless sensor network (WSN) has gradually matured under

the impetus of the two technologies of sensors and wireless communication networks. The wireless sensor network is a product of the integration of three subfields of information acquisition (sensing), information transmission, and information processing [3]. Through the cooperation between integrated microsensors, various environmental information monitored, sensed, and collected in real time are handed over to the embedded system for processing. Finally, the information is transmitted to the embedded system through a random self-organizing wireless communication network in a multi-hop relay mode, thus realizing the concept of “ubiquitous

computing.” However, the emergence of wireless sensor networks is not only an opportunity but also brings new challenges to people who study them [4].

With the advancement of wireless sensor network technology, WSN is used in more and more fields, and its main function is data collection. Obviously, only when the entire network is in an effective working state can data collection be carried out. Once the network fails, it cannot provide users with effective services [5]. Therefore, extending the lifetime of WSN is one of the important issues in the field of WSN research. The WSN link is unstable and easy to lose packets, and the loss of data packets causes the sender to retransmit, which will increase the energy consumption of the nodes in the network and shorten the network life [6]. In addition, WSN data transmission delay and network life are often mutually restrictive. The wireless sensor network is composed of a large number of wireless sensor nodes. The cost of a single node directly affects the overall cost of the network. If the overall cost is higher than the cost of using traditional sensors, it will inevitably affect the competitiveness of the wireless sensor network [7]. Due to the limitations of size, cost, and energy, the capabilities and capacity of embedded processors and memories are limited, so the computing power of wireless sensors is very limited. The number of wireless sensor nodes is large, easy to fail, and self-adaptive. Depending on the application, the number of sensor nodes may reach millions or even more [8]. In addition, sensor networks work in a relatively harsh environment. New nodes are often added or existing nodes fail. The topology of the network changes rapidly. Once the network is formed, people rarely interfere with its operation. With high robustness and fault tolerance, the corresponding communication protocol must be reconfigurable and adaptive [9].

This article is dedicated to researching a data collection scheme that can achieve the following two goals at the same time and is suitable for WSN: (1) the aggregation node in WSN collects as much data as possible in an unreliable environment and a given ideological and political education cycle; (2) effectively realize energy saving so as to extend the life of WSN. The main research methods used are constructing a data collection tree to collect data, reducing the retransmission energy consumption of nodes under the time-delayed ideological and political education cycle, and balancing the energy consumption between nodes to optimize the use of the constructed data collection tree. In view of the unstable characteristics of the WSN link, the expected transmission count (ETX) is used in data collection to measure the transmission energy consumption between nodes. In view of the requirements of real-time data and network life, a calculation packet delay is proposed. The method, combined with the remaining energy of the node, forms a network lifetime optimization problem (LOP), in order to achieve the maximum network life by combining the link quality and the remaining energy of the node under the delayed ideological and political education cycle. The communication program of wireless sensor network is systematically developed, and the hardware abstract architecture is deeply analyzed. Aiming at the problem of energy waste caused by the increase of communication distance caused by the unreasonable selection of cluster head nodes or cell head nodes in the hierarchical routing algorithm, this paper pro-

poses to use fuzzy logic methods to comprehensively consider the remaining energy value of the node and the ideological and political education cycle of the node and the three factors of the distance between the node and the sink node are selected to effectively alleviate the problem of hot nodes and, at the same time, improve the utilization of network energy. Combining the routing algorithm based on virtual grid technology to reconstruct the data routing path, only a small part of the nodes are required to adjust the path, which reduces the energy consumption cost of the routing reconstruction. At the same time, the grid technology avoids the problem of unreasonable cluster division and further improves the performance of the wireless sensor network.

## 2. Related Work

Although the large-scale commercial application of wireless sensor networks will take time due to technical constraints, in recent years, with the decline of computing costs and the smaller and smaller size of microprocessors, there have been a large number of wireless sensors. The network was put into use [10]. In fact, due to the link instability of the WSN, its topology will change over time. The PRR of the link, that is, the ratio of the number of data packets correctly received by the receiver to the total number of data packets sent by the sender, will vary with time [11]. Therefore, when some nodes do not have a path to the sink node, the network may split. In traditional routing protocols, if a node is split, it cannot pass data packets to the sink node. Therefore, network connectivity is a necessary condition for WSN data collection operations [12].

Gupta et al. [13] proved that building a data collection tree with the maximum life span is an NP problem, taking data delay as the primary consideration, optimizing network life based on the shortest path tree, constructing Data Gathering Sequence (DGS) so that nodes send data in order, avoiding cross-transmission and ideological and political education cycles, thereby optimizing the network life. Jiang et al. [14] proposed the Diffuent Traffic Routing Algorithm (DTRA), which uses an optimization model to optimize the proportion of data sent by each node to balance the network survival time and the number of data packet hops, thereby optimizing the network life. On the basis of the shortest path tree, Hang et al. [15] comprehensively considered the remaining energy of nodes in WSN and the transmission energy consumption between nodes and proposed the “proportional weight routing algorithm” and “cumulative weight routing algorithm.” Mahmoud et al. [16] proposed the LEACH routing algorithm, which is an improved algorithm based on the LEACH algorithm. Since the LEACH algorithm is based on a random model to select cluster head nodes, the number and location of the selected cluster head nodes are very uncertain. When the selected cluster head nodes are not suitable, it will cause the nodes to collect. It consumes more energy when transferring data. In response to these deficiencies, the LEACH algorithm proposes some improvements. The definition method of measuring network lifetime based on coverage is also controversial in academic circles. Some researchers believe that it is the best

standard to measure the quality of services provided by the network, while other researchers believe that only considering coverage cannot accurately define a network. Longevity, because it cannot guarantee connectivity and thus cannot guarantee that data reaches the sink node.

Chettri and Bera [17] developed a COUGAR system to test the performance of sensory data query technology and discussed how to apply distributed query processing technology to the processing of sensory data query. At the same time, the data query technology of the sensor network is studied, and the method to realize the continuous query processing that can be dynamically adjusted and the method to manage multiple queries on the sensor network are proposed, and a sensory database system is developed. Thyagarajan and Kulanthaivelu [18] proposed to combine fuzzy logic in wireless sensor networks to select cluster head nodes. This method is also an improvement based on the LEACH algorithm, which is mainly reflected in the clustering phase, while the stable operation phase is consistent with the LEACH algorithm. First, they gave three definitions of nodes: (1) the concentration of nodes, which is measured by the number of neighbor nodes of the current node; (2) the energy level of the node, that is, the remaining energy value of the current node; (3) the political education cycle measured by the distance between the node and the geometric center of the cluster. They have studied the calculation method of the aggregation function on the sensor network, proposed a tree construction algorithm for energy-saving calculation aggregation, and proved through experiments that the wireless communication mechanism has a great influence on the performance of the aggregation calculation [19–21]. Considering the real-time requirements of wireless sensor networks, researchers use the shortest path tree to collect data. However, for networks with unstable links, the number of hops between nodes is not the optimal measurement standard for measuring the distance between nodes. The data collection tree protocol uses the expected number of transmissions between nodes as the standard to measure the distance between nodes and construct data collection tree and use this to measure the delay between nodes.

### 3. Construction of a Model of Ideological and Political Education in Colleges and Universities Based on Low-Latency and High-Concurrency 5G Wireless Sensor Networks

**3.1. 5G Wireless Sensor Network Spatial Architecture.** The wireless sensor network is an independent network, and its basic unit is the wireless sensor node. Wireless sensor nodes generally consist of four main modules: sensors, microprocessors, wireless interfaces, and power management. In addition, depending on the needs of specific applications, there may be positioning systems, power regeneration units, mobile units, and so on. Figure 1 shows the spatial architecture of the 5G wireless sensor network.

In essence, a wireless sensor node is a networked distributed embedded system, which realizes communication

between networks through wireless channels. In order to reduce the amount of communication, the necessary calculations are performed locally for data fusion, so as to coordinate the collection of spatial data for deployment. In the application, the network is the center, and the function of the node is realized through the network.

$$f(x) = \{x(1), x(2), \dots, x(n) \mid n \in R\}. \quad (1)$$

In a wireless sensor network, wireless sensor nodes are randomly scattered in the monitored area. This process is completed by means of aircraft spreading, artificial embedding, and rocket ejection. The nodes form a network in a self-organizing form, and the monitoring data is transmitted to the sink node through a multihop relay method, and finally, the data in the entire area is transmitted to the remote center for centralized processing by means of a long-distance or temporarily established sink link.

$$\begin{cases} 0 < \min p(x) < f(x) - f(x-1), \\ 0 < (1+a) \times f(x) + f(x-1) < \max p(x). \end{cases} \quad (2)$$

The processor module of the wireless sensor node is responsible for controlling the operation and storage of the entire sensor node, processing data, and controlling other modules in the node. Currently, microprocessors are commonly used in wireless sensor nodes. Microprocessors are widely used in embedded systems because of their low cost, easy connection with other devices, easy programming, and low energy consumption.

$$\begin{aligned} Y(x) &= \sum_{x=1, y=1}^n p(y|x) \times f(y|x), \\ \sum_{i=1}^n p(x) \times x(i) - \sum_{j=1}^n s(i, j) \times x(j) &= R(i, j). \end{aligned} \quad (3)$$

Wireless sensor nodes also have the capability of wireless communication and can perform collaborative monitoring among nodes. The computing power and wireless communication capabilities of the nodes enable the sensor network to be reprogrammed and redeployed to respond to environmental changes, changes in the sensor network itself, and network control commands in a timely manner.

$$W(x) = \begin{bmatrix} \frac{\partial^2 f(x)}{\partial x^2} & 0 & 0 & 0 \\ 0 & \frac{\partial^2 f(x)}{\partial y^2} & 0 & 0 \\ 0 & 0 & \dots & 0 \\ 0 & 0 & 0 & \frac{\partial^2 f(x)}{\partial z^2} \end{bmatrix}. \quad (4)$$

There is no absolute control center in the sensor network. All nodes have equal status. The nodes in the network coordinate each other's behavior through distributed



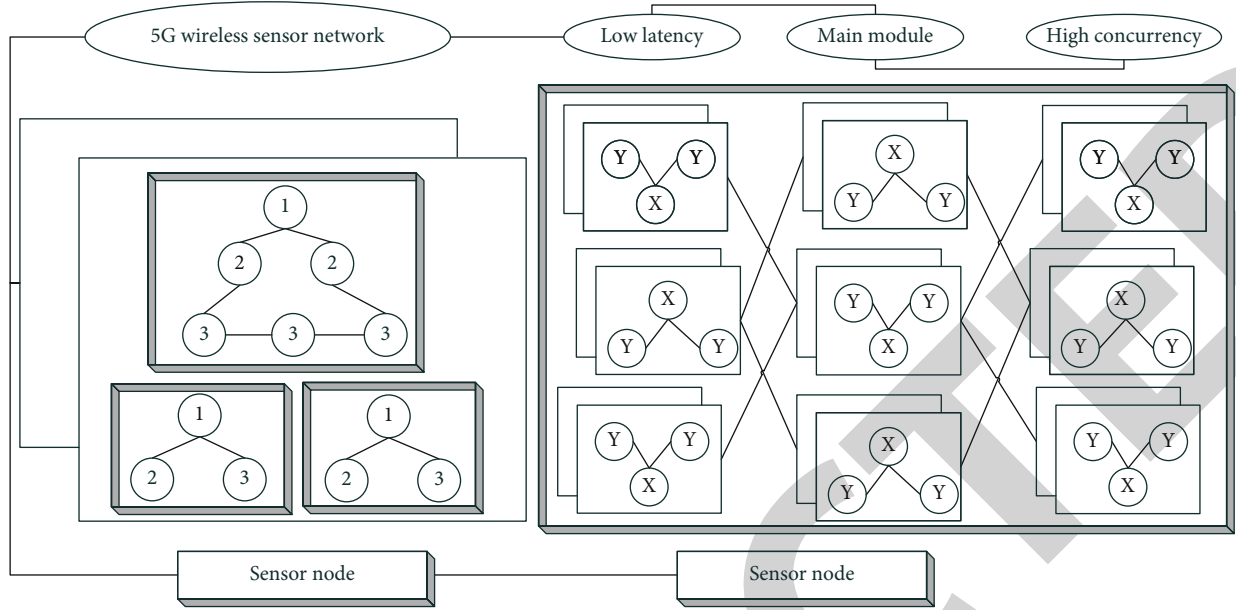

FIGURE 1: 5G wireless sensor network spatial architecture.

algorithms, without manual intervention and any other pre-set network facilities, and can be quickly deployed at any time and anywhere. Due to the distributed characteristics of the network and the redundancy of nodes, the robustness and survivability of the network are very good.

**3.2. Stratification of Ideological and Political Indicators.** The early optimization of the ideological and political education cycle of wireless sensor networks was based on the traditional low-latency and high-concurrency 5G wireless sensor network.

$$g(x) - \frac{\sum_{i,j=1}^n [s(1, i) + s(2, i) + \dots + s(j, i)]}{s(i, j)} = 0, \quad (5)$$

$$T = \operatorname{argmin}\{f(x, t)\} - \operatorname{argmin}[\exp(i - t)].$$

Many optimized algorithms and models were proposed at the physical layer, data link layer, and network layer of the network protocol stack. At the physical layer, in response to the characteristics of the ideological and political education cycle of wireless sensor networks, multiple working modes of sensor nodes are proposed: normal working mode, sleep mode, and switching mode.

$$U = \frac{1}{2} \times \int_{\Omega} \sigma(z, x)\sigma(x, y)\sigma(y, z)d\Omega. \quad (6)$$

It focuses on the analysis based on these three working modes and comprehensively considers the mathematical model of circuit energy and transmission energy. The computing power of the point is limited, and the size of the data packet sent and received is limited; on the node using the IEEE 802.15.4 protocol, the data packet of the MAC layer can only reach 127 bytes at most, and the length of the packet header usually reaches 15 bytes or more. The trans-

mission capacity of the node is limited, and the transmission bandwidth is limited to 250 Kbps. The nodes share the channel and send information through competition. Therefore, it is necessary to improve the routing effectiveness. When in an idle state, the node will always monitor the usage of the communication channel in the network and, at the same time, determine which data is sent to itself. Table 1 shows the data packet attributes of wireless sensor network nodes. When in the sleep state, the node will turn off the wireless communication module. When it is in the sending and receiving state, it will complete the data forwarding and collection work as needed. Therefore, due to the limitation of nodes in wireless sensor networks, the efficiency of nodes to send data packets is much lower than that of traditional wireless networks.

According to the status of the network, including the ratio of the number of sink nodes to the number of sensor nodes in the network, the connectivity of the network (the degree of sparseness of the link), and the speed of node update routing, we can speculate if the network constitutes an ideological and political education cycle, the total length of the ideological and political education cycle (that is, the number of nodes on the route formed from the initial formation of this route to the appearance of the first repeating node), the internal length of the ideological and political education cycle (the number of nodes inside the ring), and then according to the user's credibility requirements for judging the ideological and political education cycle, the length  $m$  value of the projected bit string ( $m$  is a multiple of 8) is obtained. In the process of wireless sensor network communication, whether it is based on a fixed aggregation node or a mobile aggregation node, sensor nodes need to determine the ideological and political education cycle of the aggregation node first and then adopt certain strategies such as single-hop or multihop communication methods. The single-hop communication process here means that

TABLE 1: Data packet attributes of wireless sensor network nodes.

Network index	Wireless protocol	Working frequency (GHz)	Transmission rate (Mbps)	Communication range (m)
1	IEEE802.11a	2.4	10	0-100
2	IEEE802.11b	2.5	53	10-100
3	IEEE802.11h	3.2	2.1	0-10
4	IEEE802.11g	2.6	0.6	50-100

when the node detects that the sink node is located in the area within its communication range, it actively generates sensing data information to the sink node. The multihop communication process refers to the process in which a node can communicate with other nodes to transmit data to the sink node.

**3.3. Low-Latency and High-Concurrency Optimization Processing.** In a sensor network, the function of each node is the same. A large number of wireless sensor nodes are arranged in the entire observation area. Each node transmits the detected useful information to the user through preliminary data processing and information fusion. The data transmission process is transmitted back to the base station through the relay transmission of adjacent nodes, then transmitted to the end user through the base station via satellite channel or wired network connection. The energy consumed by the wireless communication part accounts for the largest proportion of the total energy consumed, and the closer it is to the sink node, the more likely it is that the node will become a routing node, and the more messages will be forwarded. The wireless sensor network uses wireless transmission technology as the underlying communication means. Due to the physical characteristics of the wireless channel itself, the network bandwidth it can provide is much lower than that of the wired channel. In addition, considering various factors such as conflicts, signal attenuation, noise, and interchannel interference caused by competing for shared wireless channels, the actual bandwidth obtained by the sensor terminal is far less than the theoretical maximum bandwidth.

In terms of data transmission reliability, the mechanism of retransmission by the sender after data transmission failure and confirmation by the receiver after successful data transmission is adopted. Figure 2 shows the low-latency and high-concurrency optimization processing flowchart. There is a timer in the node, and the timer is started when sending data. When the timer stops, the sender still does not receive the ACK (acknowledgement packet) from the receiver; the sender determines that the data packet is lost and performs retransmission. Although the probability of packet loss varies according to the stability of the network, studies have shown that because the length of the ACK packet is very short, even in a very unstable link environment, the probability of ACK loss is very small. When calculating node energy consumption, only the energy consumption for sending and receiving is considered, and the energy consumption caused by other reasons is not considered. As mentioned above, the wireless transceiver in the wireless communication module consumes the most energy

in the entire node. Its communication energy consumption is often several orders of magnitude larger than the computational energy and perceptual energy consumption. Therefore, the computational energy and perceptual energy consumption can be ignored for perceived energy consumption and other energy consumption.

Figure 3 shows the linear fitting of the node stability of the wireless sensor network. The wireless communication module of the wireless sensor node is responsible for wireless communication with other sensor nodes, exchanges control messages, and sends and receives collected data. The wireless sensor node is often used as both a terminal receiving point and a relay node. The wireless transmitter and receiver are combined into one device called a transceiver. The transceiver has a variety of states, including transmitting, receiving, idle, and dormant states. For most nodes, the energy consumption in the idle state is close to the energy consumption in the receiving state, so the best way is to turn off the receiver to save energy when the node is not in the transmitting or receiving state. And the node farther away from the sink node will become a routing node, the lower the probability is, the fewer messages will be forwarded. The model not only refers to the architecture of the TCP/IP and OSI models of the existing general network but also includes the unique power management, mobility management, and task management of the sensor network. The application layer provides a relatively uniform high-level interface for different applications; if necessary, the transport layer can maintain data flow for the sensor network or ensure that it is connected to the Internet; the network layer is mainly concerned with data routing; the data link layer is responsible for the data flow multiplexing, data frame detection, media access, and error control; the physical layer provides a simple and stable modulation, transmission, and reception system for the system. In addition, power, mobility, and task management are responsible for the monitoring of sensor node energy, mobility, and task allocation, helping sensor nodes to coordinate sensing tasks, and minimize the power consumption of the entire system.

#### 4. Application and Analysis of College Ideological and Political Education Model Based on Low-Latency and High-Concurrency 5G Wireless Sensor Network

**4.1. Low Latency and High Concurrent Data Iteration.** In this paper, the data accuracy rate is defined as  $K/N$ , where  $K$  is the number of sensor nodes that successfully send data to the sink node in a round of data collection. Since the data

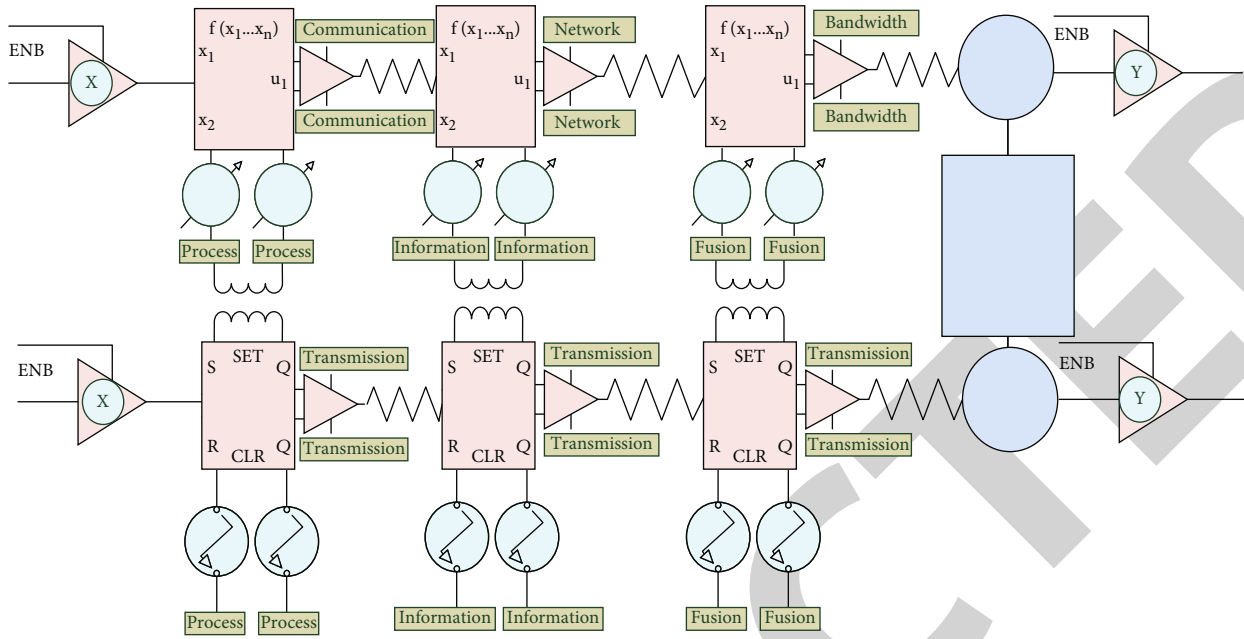

FIGURE 2: Low-latency and high-concurrency optimization processing flowchart.

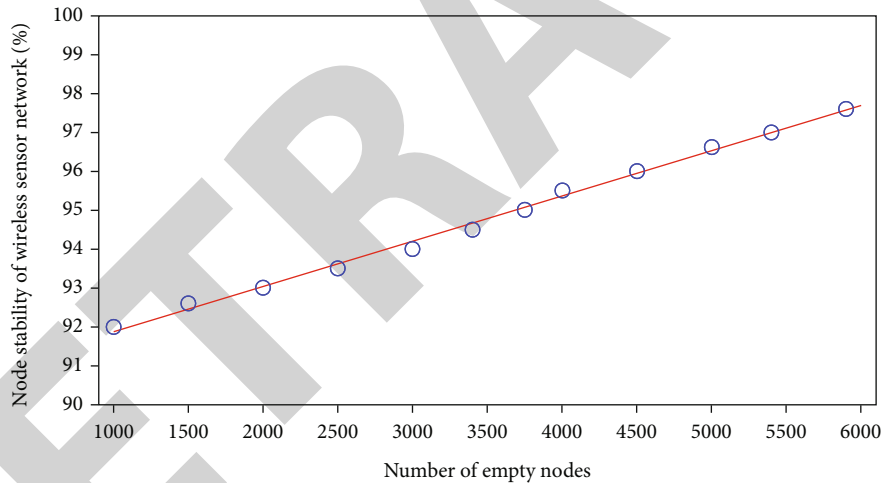

FIGURE 3: Linear fitting of node stability of wireless sensor network.

collection method is adopted in this paper to collect data, if a data packet is lost in the process of sending from node  $a$  to its parent node, the data of the subtree with node  $a$  as the root node will be lost. After the cluster is divided using the LEACH protocol, the remaining energy of all the member nodes in the cluster, the distance from the node to the cluster center, and the distance to the mobile gateway are three variables as input parameters, according to the preset fuzzy rules. After the fuzzy calculation module, the priority of the current node as the cluster head node is finally output, and the new cluster head node with the highest priority is responsible for collecting the sensory data in the cluster and uploading it to the mobile gateway. The ideological and political education cycle of the node here is the distance from the node to the center of the cluster. Through the analysis of the particularity of wireless sensor networks, the eval-

uation indicators of time synchronization algorithms for wireless sensor networks include not only synchronization accuracy and convergence time in traditional networks but also specific indicators of wireless sensor networks. It can be seen that the average path energy consumption increase value will not fluctuate greatly with the increase of the energy capture rate but basically remains unchanged. The reason is as follows. For the shortest path routing scheme, increasing the energy capture rate will not affect the total energy consumption of the path, but it will increase the throughput of the data stream. For high-throughput and energy-aware routing schemes, increasing the energy capture rate has little effect on the total energy consumption of the path, but it will greatly increase the flow throughput. Figure 4 shows the throughput error statistics of wireless sensor network nodes.

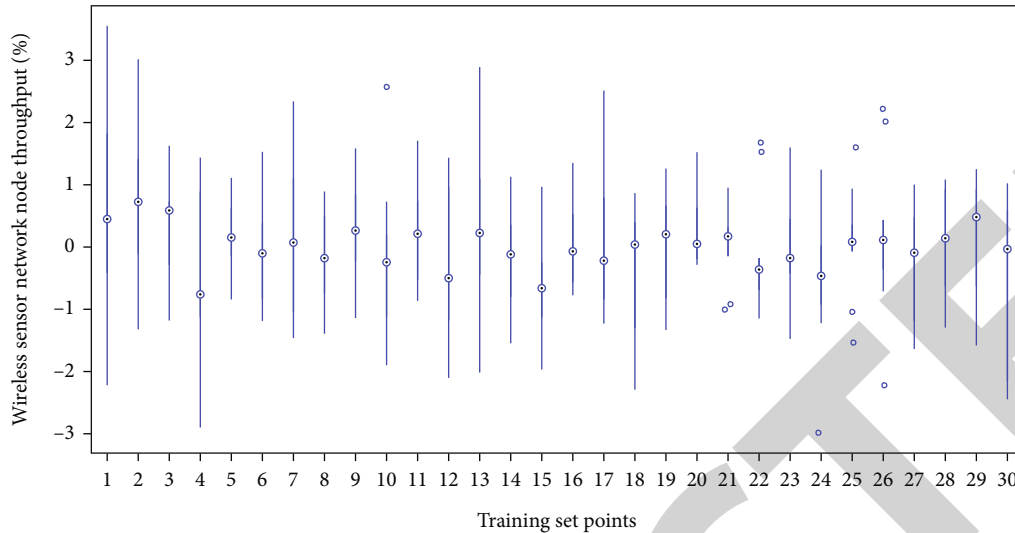

FIGURE 4: Throughput error statistics of wireless sensor network nodes.

This section compares the total energy consumption of the network with the high performance of the spanning tree from the two aspects of the tree height ideological and political education cycle and the number of nodes. The experimental results are the average results after 100 executions. When the remaining energy value of a sensor node is zero, because it has been unable to collect and forward data by itself, this article considers that the node has “dead.” Existing routing algorithms believe that the life cycle of a wireless sensor network depends on the length of a period of time from the beginning of the wireless sensor network’s operation to the occurrence of the first dead node. Therefore, this article first carried out simulation experiments on the cases where the direct and indirect cell head node interchange cycles were 5, 10, 20, and 40 s when the moving speed of the mobile aggregation node was 10 m/s. It can be seen from the simulation results that, under a high signal-to-noise ratio, the average capture time and average feedback times required to achieve synchronous capture of tag nodes are less than the original single-step capture and two-step capture algorithms, which significantly improves the capture speed, and the number of feedbacks is reduced, and the power consumption of the tag node is reduced. Therefore, under the condition of a high signal-to-noise ratio, the performance of the synchronization error estimation algorithm is better than single-step acquisition and two-step acquisition algorithms. As the node fails, the network topology changes. However, the nodes are not the joint points of the network, so the network can continue to operate. Compared with LEACH, the optimization of network energy consumption has been improved to a certain extent, but it is not obvious. The fuzzy logic-based routing algorithm proposed in this paper also considers the remaining energy value of the node, the ideological and political education cycle of the node, and the distance between the node and the mobile gateway to select the cluster head. The simulation results also show that the method is improving the network performance. In terms of efficiency, it has a significant improvement effect than other similar methods.

#### 4.2. Realization of 5G Wireless Sensor Network Simulation.

This article uses the MATLAB simulation tool to simulate TEDAS and GEDAS. This chapter will show the experimental results of TEDAS and GEDAS and analyze their performance. Set  $N = 100$ , the sensor nodes are randomly distributed in an area of  $100 \text{ m} \times 100 \text{ m}$ , and the sink node is located in the center of the area. Each node is given a random initial energy between 1 and 10 J. The link composed of two nodes is based on the proposed model, which is a wireless channel model based on statistics of the actual system measurement values. In the link scheduling process, for each forwarding node, because it needs to perceive data, the amount of data on its output link is greater than all its input links, so it is preferred to assign time slots to links with a small amount of data to ensure the input link. The channel time slot is determined before the output link time slot. Since the range of the sensing area is defined as  $100 \times 100 \text{ m}^2$ , the distance between nodes is between 0 and 100. Before substituting the fuzzy logic model, the distance value is unitized. The processing is then multiplied by a factor of 2 to meet the requirements of the input variable set range.

This paper uses simulation experiments to test the energy-saving routing algorithm based on virtual grid technology to achieve channel exchange. The whole simulation experiment is divided into two parts: first, set the mobile aggregation nodes to operate at different speeds (10 m/s, 15 m/s, and 20 m/s) and the direct and indirect cell head node conversion cycle (5 s, 10 s, 20 s, and 40 s) to find the parameter value that maximizes the network performance. Figure 5 shows a line graph comparing the operating speed of wireless sensor network nodes. Then, in the same environment, simulation experiments were carried out on the algorithms, and the effectiveness of the routing algorithm proposed in this chapter was verified through the experimental result data. From the test results, it is obvious that when the exchange period of the direct and indirect cell head nodes is 5 s, the life cycle of the wireless sensor network is the longest. After updating the network topology and parameters, the loop enters the second calculation to obtain the cross-layer scheduling strategy. In order



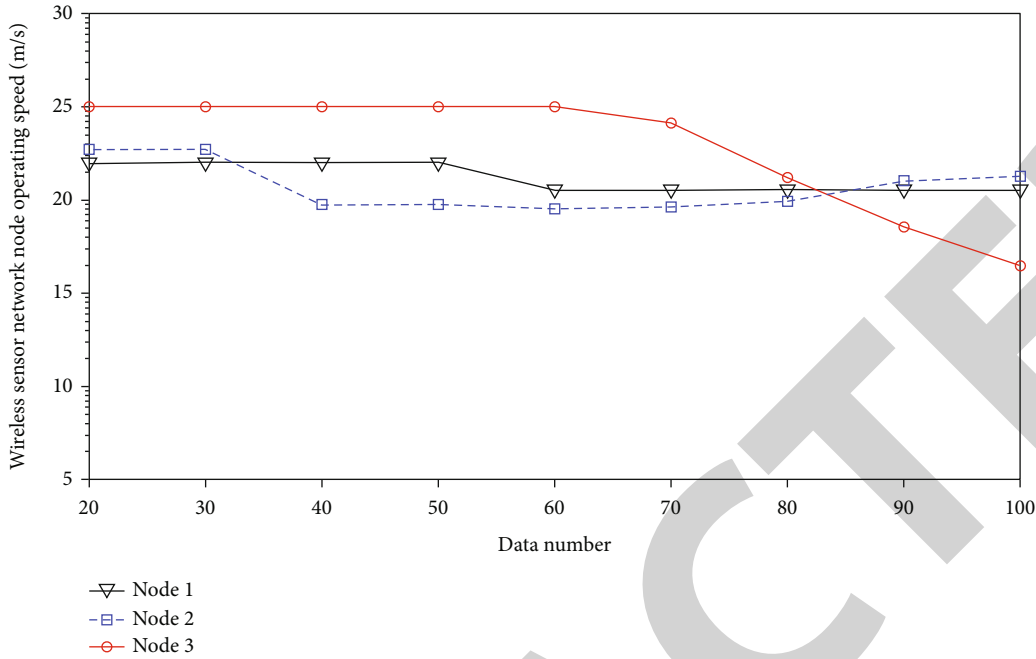

FIGURE 5: Line graph of comparison of node operating speed in wireless sensor network.

to further accurately describe the performance comparison of the wireless sensor network under different conditions, we counted the number of rounds in which the first, half, or all dead nodes appeared during each experiment. As the tree height limit increases, the total network energy consumption and tree height corresponding to the MST algorithm remain unchanged. With the increase of the hop limit, the DCT algorithm and IGPS algorithm reduce the total energy consumption of the network. The total energy consumption of the two networks is greater than that of the MST algorithm, and the tree height is less than that of the MST algorithm. Under the same hop limit, compared with DL-DCT, the IGPS algorithm presented in this paper reduces the total energy consumption of the network by 7.76%. Figure 6 shows a histogram of the reduction in energy consumption of wireless sensor networks. Therefore, under different hop count cycles of ideological and political education, the total energy consumption of the data collection tree generated by the IGPS algorithm given in this paper has obvious advantages.

It can be seen that although the number of rounds of the first dead node when the direct and indirect cell head node swap cycle is 5 s is larger, when the swap cycle is 40 s, the number of rounds when all nodes die is 100 more than it runs. Therefore, this article analyzes the second half of the process of the wireless sensor network operation. The hollow circles are ordinary sensor nodes that are alive, the circles with crosses indicate the dead sensor nodes, and the solid circles are the cells in the current communication process. It can be seen from the figure that in the second half of the network operation, the surviving nodes are basically concentrated in the center of the entire network area, and the dead nodes will spread from the network boundary to the center during the entire network operation. The cycle-based cross-layer optimization algorithm for the lifetime of wireless sensor networks

can further extend the network lifetime than the traditional cross-layer optimization algorithm for the lifetime of the wireless sensor network. When the exchange period is small, the cell head node will perform the routing path reconstruction process more frequently. It is this process that consumes the energy of the sensor node more quickly.

**4.3. Example Application and Analysis.** This section studies the impact of network size on network life span under various data collection methods. We deploy 100 nodes within  $100\text{ m} \times 100\text{ m}$ , 400 nodes within  $200\text{ m} \times 200\text{ m}$ , and 900 nodes within  $300\text{ m} \times 300\text{ m}$ . Under the condition of ensuring network density as much as possible, we compare the performance of each data collection method to obtain the network life histogram of each data collection method (due to the large network scale and the genetic algorithm consumes a lot of time, the simulation in the network scale direction is not implemented in this section). It can be seen that the network life of the tree formed by each data collection method decreases with the expansion of the network scale, but under different network scales, it is better than the other three data collection methods. Figure 7 shows the histogram of the remaining energy value of the wireless sensor network. It can be seen from the comparison result that the LEACH protocol simply relies on the random number and does not consider the remaining energy value of the node when selecting the cluster head. Therefore, the sensor node is the first to die and the network life cycle is the shortest. The routing algorithms both consider two factors when selecting cluster heads. The former considers the node's ideological and political education cycle and the remaining energy value, while the latter considers the remaining energy and the distance between the node and the base station.

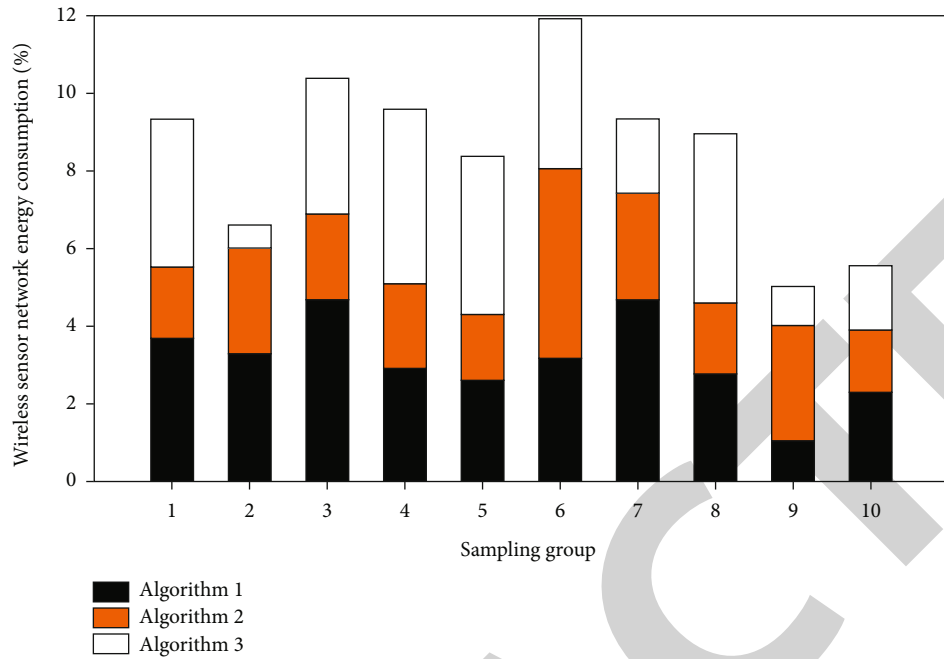

FIGURE 6: Bar graph of the proportion of wireless sensor network energy consumption reduction.

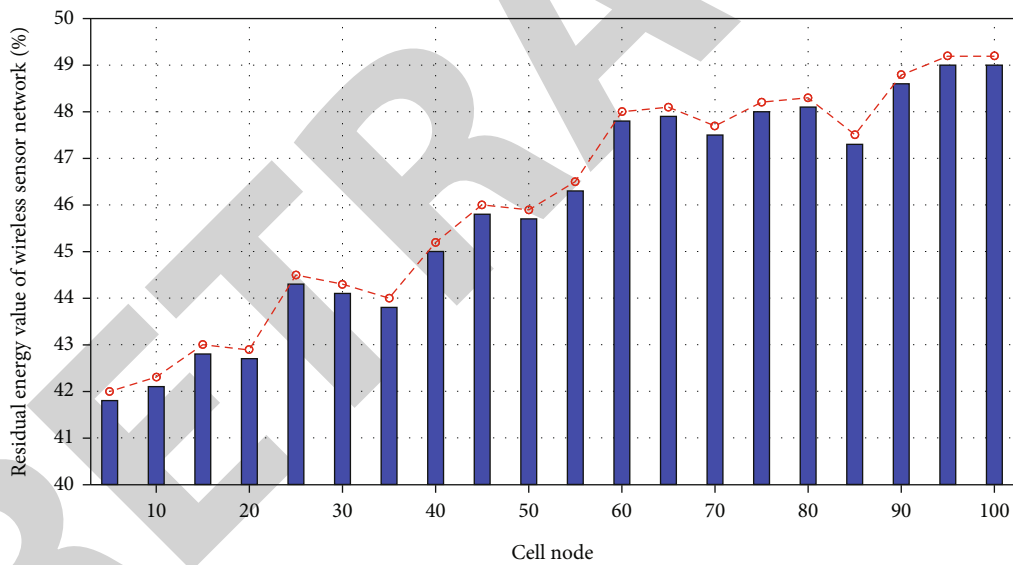

FIGURE 7: Histogram of the residual energy value of wireless sensor network.

In order to further study the best value of the direct and indirect cell head node interchange cycle to improve the performance of wireless sensor network, this paper records the changes of the network life cycle when the value is different. It can be seen that when the direct and indirect cell head node interchange period is 5 s and 10 s, the performance change of the wireless sensor network is not very obvious. Similarly, the change in the swap period between 20 s and 40 s is not significant. Therefore, this article only shows the cases where the swap period is 5 s and 40 s, respectively. The average capture time of the algorithm and the average number of feedbacks are a pair of

contradictions. When the average number of times is larger, the more accurate the estimated value of the phase difference of the tag node is, the less the average number of feedbacks required to achieve synchronization capture. This paper chooses MATLAB to carry out the simulation experiment of the energy-saving routing algorithm based on the fuzzy method to realize the clustering, mainly to carry out the performance experiment of the energy consumption of the algorithm in the wireless sensor network and the network life cycle. Figure 8 shows a ladder diagram of the life cycle of a wireless sensor network node. This article assumes that the coverage

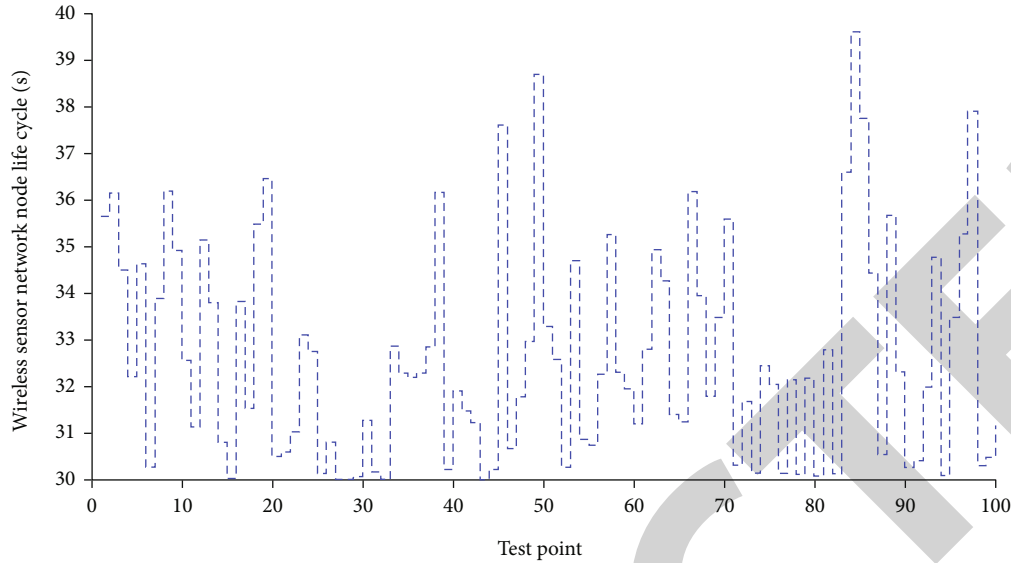

FIGURE 8: Life cycle ladder diagram of wireless sensor network nodes.

area of the network is a rectangular area of  $100 \times 100 \text{ m}^2$ , in which 100 sensor nodes are randomly deployed, and each sensor node has the same initial energy value. The mobile aggregation node can move freely within the network coverage area and is used to collect the sensory data information uploaded by the cluster head node.

Under the MATLAB simulation platform, the relationship between the average number of times required to achieve the correct estimation of synchronization errors under different SNR is simulated. The simulation conditions are set to  $P = 0.95$ , the average power of the pulse signal  $\gamma$  is 1, and the maximum allowable synchronization phase difference is  $0.1T$ . It can be seen that as the signal-to-noise ratio increases, that is, the noise power decreases, the number of averaging required for correct estimation is continuously reduced. When the signal-to-noise ratio is low, the variance of the synchronization error estimate is larger. Therefore, the deviation of the estimated value of the phase difference is correct and the probability of the difference is greater, and more averaging times are required. On the contrary, when the signal-to-noise ratio is high, the variance of the synchronization error estimate is small, so the probability that the phase difference estimate is correct is small, and the number of averaging required is less, and the theoretical analysis results in the figure are consistent with the simulation results, which illustrates the theoretical analysis correctness. The biggest difference between the host synchronization scheme based on the phase error estimation algorithm and the ideological and political education cycle of the pulse host is that the host node does not adjust the phase of the transmitted signal autonomously but adjusts the phase according to the synchronization error estimated value fed back by the tag node. This can significantly increase the capture speed of the tag node, reduce the capture time, and, at the same time, reduce the number of feedback of the tag node, and reduce the energy consumption of the node.

## 5. Conclusion

Based on the low-latency and high-concurrency 5G wireless sensor network, this paper proposes the concept of the ideological and political education cycle, and the necessary derivation and proof of the model. Then, a loop-based algorithm is given to solve the mathematical model. Based on these, this article first introduces the challenges faced by the ideological and political education cycle in the wireless sensor network and the indicators for evaluating the ideological and political education cycle and then introduces the current research status of the ideological and political education cycle and introduces the current representative ideological and political education. And finally, a comprehensive comparative analysis of these cycles of ideological and political education is given. On this basis, the network communication program is given and the communication test is carried out. Then, the mathematical model is solved by LINGO, and the cross-layer optimized scheduling strategy and the life span of the wireless sensor network are obtained. The calculation result of the mathematical model shows that compared with the traditional optimization algorithm, the algorithm proposed in this paper further extends the network ideological and political education cycle. The simulation was carried out on the MATLAB simulation platform to verify the correctness of the theoretical analysis results. At the same time, under nonideal channel conditions, the advantages and disadvantages of the algorithm and the pulse host ideological and political education cycle are compared, which shows that the acquisition performance of the phase error estimation algorithm is better than the pulse host ideological and political education cycle in terms of capture duration and feedback times. By analyzing the energy consumption of the wireless sensor network, finally, the energy optimization strategy of the wireless sensor network is given. And there is no significant increase in the complexity of the label node, which achieves the purpose of reducing the

power consumption of the label. At the same time, the wireless sensor network is used to build a time synchronization experiment platform and perform experiments on the platform, and the experimental results are obtained. Finally, the data is analyzed according to the results, and the synchronization accuracy is tested. The accuracy of the synchronization algorithm is very high, and it can well meet the accuracy requirements. This paper studies the cross-layer optimization of wireless sensor networks proposed in recent years, compares the characteristics between cross-layer optimization and traditional layered optimization, and points out the breakthrough of traditional layered network protocol architecture based on cross-layer optimization solutions. Compared with the existing hierarchical optimization scheme, the cross-layer optimization method further improves the ideological and political education cycle of wireless sensor networks and makes the overall network traffic more balanced.

### Data Availability

The data used to support the findings of this study are available from the corresponding author upon request.

### Conflicts of Interest

The author declares no known competing financial interests or personal relationships that could have appeared to influence the work reported in this paper.

### References

- [1] N. Zhang, X. Chen, and H. Yin, "Significance and possibility of VR technology embedded in the teaching of ideological and political theory course in colleges and universities," *IEEE Access*, vol. 8, pp. 209835–209843, 2020.
- [2] H. Liu, "Smart campus student management system based on 5G network and internet of things," *Microprocessors and Microsystems*, p. 103428, 2020.
- [3] Q. Hou, M. Han, and Z. Cai, "Survey on data analysis in social media: a practical application aspect," *Big Data Mining and Analytics*, vol. 3, no. 4, pp. 259–279, 2020.
- [4] P. Kasznar, A. W. A. Hammad, M. Najjar et al., "Multiple dimensions of smart cities' infrastructure: a review," *Buildings*, vol. 11, no. 2, p. 73, 2021.
- [5] R. Li, K. Chen, and D. Wu, "Challenges and opportunities for coping with thee smart in rural America," *Smart Spaces and Places*, vol. 44, 2021.
- [6] D. Camacho, Á. Panizo-Lledot, G. Bello-Orgaz, A. Gonzalez-Pardo, and E. Cambria, "The four dimensions of social network analysis: an overview of research methods, applications, and software tools," *Information Fusion*, vol. 63, pp. 88–120, 2020.
- [7] P. Tan, K. Mao, and S. Zhou, "Image target detection algorithm of smart city management cases," *IEEE Access*, vol. 8, pp. 163357–163364, 2020.
- [8] F. Xu, H. Ye, F. Yang, and C. Zhao, "Software defined mission-critical wireless sensor network: architecture and edge offloading strategy," *IEEE Access*, vol. 7, pp. 10383–10391, 2019.
- [9] T. Mahmood, J. Li, Y. Pei et al., "An intelligent fault detection approach based on reinforcement learning system in wireless sensor network," *The Journal of Supercomputing*, pp. 22–30, 2021.
- [10] C. Miranda, G. Kaddoum, E. Bou-Harb, S. Garg, and K. Kaur, "A collaborative security framework for software-defined wireless sensor networks," *IEEE Transactions on Information Forensics and Security*, vol. 15, pp. 2602–2615, 2020.
- [11] G. Hampel, C. Li, and J. Li, "5G ultra-reliable low-latency communications in factory automation leveraging licensed and unlicensed bands," *IEEE Communications Magazine*, vol. 57, no. 5, pp. 117–123, 2019.
- [12] Z. Feng, "Protocol for reliable energy data collection based on mobile fog computing," *Sustainable Energy Technologies and Assessments*, vol. 44, p. 101086, 2021.
- [13] N. Gupta, K. S. Vaisla, and R. Kumar, "Design of a structured hypercube network chip topology model for energy efficiency in wireless sensor network using machine learning," *SN Computer Science*, vol. 2, no. 5, pp. 9–13, 2021.
- [14] J. Jiang, H. Wang, X. Mu, and S. Guan, "Logistics industry monitoring system based on wireless sensor network platform," *Computer Communications*, vol. 155, pp. 58–65, 2020.
- [15] N. T. T. Hang, N. C. Trinh, N. T. Ban, M. Raza, and H. X. Nguyen, "Delay and reliability analysis of p-persistent carrier sense multiple access for multi-event industrial wireless sensor networks," *IEEE Sensors Journal*, vol. 20, no. 20, pp. 12402–12414, 2020.
- [16] H. H. Mahmoud, H. M. ElAttar, A. Saafan, and H. ElBadawy, "Optimal operational parameters for 5G energy harvesting cognitive wireless sensor networks," *IETE Technical Review*, vol. 34, Supplement 1, pp. 62–72, 2017.
- [17] L. Chettri and R. Bera, "A comprehensive survey on internet of things (IoT) toward 5G wireless systems," *IEEE Internet of Things Journal*, vol. 7, no. 1, pp. 16–32, 2019.
- [18] J. Thyagarajan and S. Kulanthaivelu, "A joint hybrid corona based opportunistic routing design with quasi mobile sink for IoT based wireless sensor network," *Journal of Ambient Intelligence and Humanized Computing*, vol. 12, no. 1, pp. 991–1009, 2021.
- [19] M. Y. Arafat, M. A. Habib, and S. Moh, "Routing protocols for UAV-aided wireless sensor networks," *Applied Sciences*, vol. 10, no. 12, p. 4077, 2020.
- [20] A. Slalmi, H. Chaibi, R. Saadane, A. Chehri, and G. Jeon, "5G NB-IoT: efficient network call admission control in cellular networks," *Concurrency and Computation: Practice and Experience*, vol. 33, no. 22, p. 6047, 2021.
- [21] J. Oostvogels, F. Yang, S. Michiels, W. Joosen, and D. Hughes, "Zero-Wire," *Get Mobile: Mobile Computing and Communications*, vol. 25, no. 1, pp. 34–38, 2021.