

Research Article

Multisign Health Monitoring Technology of Athletes Based on Artificial Intelligence

Long Cai  and Yuan Zheng 

Weinan Normal University, Weinan, Shaanxi 714099, China

Correspondence should be addressed to Long Cai; ywx@zjnu.edu.cn

Received 8 March 2022; Revised 14 May 2022; Accepted 16 May 2022; Published 27 May 2022

Academic Editor: Pradeep Kumar Singh

Copyright © 2022 Long Cai and Yuan Zheng. This is an open access article distributed under the Creative Commons Attribution License, which permits unrestricted use, distribution, and reproduction in any medium, provided the original work is properly cited.

In order to improve the monitoring efficiency of physical fitness characteristics of athletes in training state, this paper proposes the research on athletes' multisign health monitoring technology based on artificial intelligence sensor technology. Taking six excellent boxers as the experimental objects, four weeks of heavy load training and 10 training courses per week were arranged from six weeks before the competition to two weeks before the competition. The 4-week training is divided into two stages. From the first week to the fourth week, the training amount remains unchanged and the training intensity increases. The artificial intelligence sensor technology is used to design the athlete training state pulse test system. The athlete training state pulse sensor is responsible for collecting the athlete training state pulse data. The athlete pulse sensor in this system adopts zn17-kg200 pulse vibration sensor as the pulse sampling sensor. After 4 weeks of heavy load training, before and after adjusting for rest, venous blood was taken fasting on the next morning. White blood cells (WBC), red blood cells (RBC), hemoglobin (hemoglobin, Hb), testosterone (hemoglobin, H), cortisol (cortisol), and testosterone/cortisol ratio were measured. The experimental results showed that T and T/C of athletes were significantly lower than those before training ($P < 0.01$), 37.99% and 52.69%, respectively. C and morning pulse were significantly higher than those before training ($P < 0.05$), with an increase range of 32.39% and 20.39%. There was no statistical significance in the changes of WBC, RBC, and Hb. HRV indexes $\ln LF$ and LF/HF were significantly higher than those before training. Athletes carry the designed portable athlete training state pulse test for heavy load training and display the current training state pulse data of each athlete in real time. The experimental data show that the system designed in this paper can monitor the pulse information of athletes in the training state in real time. The monitoring has good real-time result and accuracy and can realize the abnormal pulse alarm, which has a certain practical value.

1. Introduction

In the process of sports, the change of pulse can effectively reflect the physical function and health level of athletes. Through the pulse test of athletes' training state, we can scientifically grasp the sports training state of athletes and analyze the individualized physical function characteristics of athletes, which is of great significance to guide sports training and protect athletes' health [1]. The pulse test of athletes' training state is based on the sensor monitoring technology. By wearing the vibration sensor of pulse test, the pulse information of athletes can be fed back in real time. Combine the digital information processing system to analyze the characteristics of pulse infor-

mation, realize pulse test and automatic alarm, and transmit the pulse data of athletes' training status to the test center. If there is an athlete's pulse or heart abnormality, an abnormal pulse signal will be generated to realize early judgment and discovery. Shown in Figure 1 is the hardware circuit integrated design diagram of the pulse tester [2]. After computer, artificial intelligence, and mobile communication, artificial intelligence technology has become a typical representative of the third information industry revolution [3]. It carries out application services and business innovation through the operation of modules such as object connection, intelligent perception, big data computing, and intelligent identification, which has brought a positive and far-reaching impact on people's

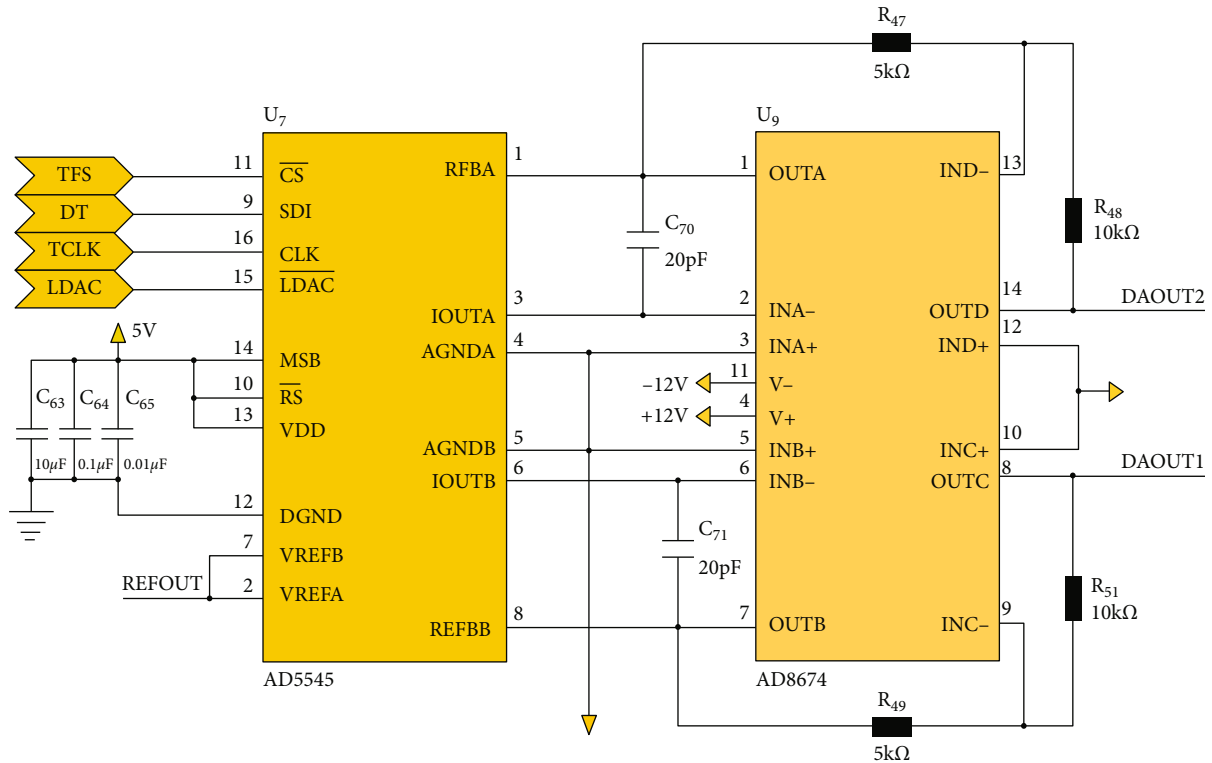

FIGURE 1: Integrated design of hardware circuit of pulse tester.

production and life. Artificial intelligence technology has been developed into various wearable products and supporting equipment for real-time physical health monitoring because of its many advantages, such as visual design, real-time data acquisition, motion trajectory tracking, energy consumption judgment, exquisite and easy to carry, and remote monitoring [4]. As we all know, the physical health status of athletes is dynamic, complex, long term, and multifaceted, while the annual physical health test stipulated by the Ministry of Education is fixed, programmed, and limited (it has some problems, such as less shared information, poor timeliness, insufficient in-depth mining of data information, and insufficient connection with the rapid development of information technology). Therefore, how to effectively introduce artificial intelligence technology into athletes' physical health test, realize real-time and effective monitoring and management of athletes' physique, and extend follow-up services should be a major and practical problem to be solved [5]. The training load of competitive sports is close to the physiological limit of the human body, which will inevitably lead to exercise fatigue. If the diagnosis of fatigue is not clear or ignored, it will lead to overtraining and hinder the improvement of exercise ability.

2. Literature Review

Aiming at this research problem, Ye and others confirmed that during one-time exercise, with the deepening of exercise fatigue, HRV indicators RMSSD and LF gradually decreased, and the activities of parasympathetic nerve and sympathetic nerve were gradually inhibited [6]. Yoshihide showed that

after 6 to 9 weeks of heavy load training/overtraining, the low-frequency power of R-R interval of female athletes increased significantly and the sympathetic nerve activity increased [7]. Daroogheh and others showed that the changes of autonomic nervous system caused by long-term training with different loads (followed by high-intensity physical training in February, overload training in January, and recovery training in two weeks) were different, and most indicators of heart rate variability (HF, RMSSD, pNN50, SDNNIDX, and SDNN) increased significantly during high-intensity physical training [8]. Li and others studied that after training, the CK level increased by about 4 times and the pain increased significantly, suggesting that weightlifters reached a state of fatigue. The decrease of HF after training indicates that the parasympathetic activity is inhibited, and the significant increase of LF 3 hours after training indicates that the sympathetic excitability is enhanced [9]. Wei and others experimentally developed a microwave Doppler radar to search for wounded soldiers during war. Due to the application of microwave transmission technology, the basic information of heartbeat and respiration can be obtained without any sensors of patients and wounded and can be used for the search of patients and wounded [10]. Barchi and others use the integrated storage technology, which is similar to the IC card. The personal information carrier, which is worn at the neck, wrist, etc. and stores all the medical information of soldiers, is widely used in military telemedicine equipment [11]. Xiao and others have done a lot of work in developing this military equipment and sponsored some projects to study how to collect injury and death data to improve the survivability of soldiers

[12]. The individual vital sign monitoring plan proposed by Kam and others is a combat environment design, which comprehensively monitors the physiological and psychological state of the system. The system can not only monitor the combat ability of uninjured soldiers but also assist medical personnel in remote processing after soldiers' examination [13]. Fu and others use VXI system bus to send the conditioning signal output result of pulse test to the core controller for sports training state characteristic analysis [14]. Zhe and others believe that the software layer is to realize the software test of the pulse test system and the program development of the system. The middle layer refers to the layer between the hardware layer and the software layer, which can be set independently, such as input range and single end input, to modulate, demodulate, and cache the pulse test data, and use Motorola 56002 fixed-point DSP to complete the middle layer design of the pulse test system [15]. Fei and others believe that the sensor technology is used to continuously collect data to the main control computer, and the collected data will be transmitted to the expert system through the network for data analysis. Combined with the big data information processing technology, it can realize the characteristic analysis of the athletes' training status and the regulation of physical functions. According to the individual differences of athletes' physical characteristics, a reasonable training program is formulated [16]. Based on the current research, this paper puts forward the research on athlete's multisign health monitoring technology based on artificial intelligence sensor technology. Six elite boxers were selected as subjects. The elbow venous blood was collected on an empty stomach the next morning before and after the adjustment rest of the 4-week precompetition training stage. The concentrations of leukocytes, erythrocytes, hemoglobin, serum testosterone, and cortisol were measured. The morning pulse and heart rate variability after waking up were measured on the day of blood collection, and the exercise psychological fatigue questionnaire (ABQ) was filled out after breakfast. The experimental results showed that T and T/C of athletes were significantly lower than those before training ($P < 0.01$), 37.99% and 52.69%, respectively. C and morning pulse were significantly higher than those before training ($P < 0.05$), with an increase range of 32.39% and 20.39%. There was no statistical significance in the changes of WBC, RBC, and Hb. HRV indexes lnLF and LF/HF were significantly higher than those before training. Athletes carry the designed portable athlete training state pulse test for heavy load training and display the current training state pulse data of each athlete in real time. The experimental data show that the system designed in this paper can monitor the pulse information of athletes in the training state in real time. The monitoring has good real-time result and accuracy and can realize the abnormal pulse alarm, which has a certain practical value.

3. Method

3.1. Research Object. There are 6 excellent boxers, all at the level of athletes, in good health, without injuries and diseases. See Table 1 for basic information.

TABLE 1: Basic information of subjects.

Age (year)	Height (cm)	Body weight (kg)	Training years (year)
23.43 ± 3.11	175.19 ± 11.49	68.41 ± 21.34	8.19 ± 2.23

3.2. Experimental Method

3.2.1. Training Arrangement. Coaches have arranged 4 weeks of heavy load training and 10 training classes per week from 6 weeks before the competition to 2 weeks before the competition. Three times of high-intensity actual combat, three groups of 3×3 min actual combat in the form of competition, and then move and hit the sandbag in 12×30 s (intermittent 30 s). The actual combat is carried out according to the competition intensity. The mobile and hit sandbag is carried out with personal maximum strength and maximum speed, and the heart rate is controlled at 95%~100% of the maximum heart rate; 3 times of special technical training, including special pace, intermarching training, two-person confrontation, personal air strike, hitting hand target and sandbag, with a training time of 90 min; 2 times of physical fitness training, including strength, speed, and endurance training, with a training time of 120 min; 2 times of combined training of special technology and special physical fitness, with the training time of 120 min. The 4-week training is divided into two stages. The first stage is from the first week to the second week, focusing on strengthening special technical and physical quality training, and the second stage is from the third week to the fourth week, focusing on increasing the intensity and difficulty of practical training. From the first week to the fourth week, the training amount remains unchanged and the training intensity increases.

3.2.2. Test Index and Method. Physiological indicators: after 4 weeks of heavy load training, before and after the adjustment of rest, the next morning, the venous blood was taken fasting on the next morning to detect white blood cells (WBC), red blood cells (RBC), hemoglobin (hemoglobin, Hb), testosterone (hemoglobin), cortisol (Hg), testosterone/cortisol ratio, etc.

Morning pulse: after waking up in the morning, wear suntot6d heart rate meter in supine position, collect 5 min data, and take the average value.

Psychological indicators: athletes' psychological fatigue questionnaire (ABQ) was used to measure athletes' psychological fatigue [17].

HRV test: wear suntot6d heart rate meter and set the sampling frequency to 2S. After supine position, quiet and stable breathing, continuously collect 10 min and intercept 5 min stable data. The time domain and frequency domain indexes of HRV are processed and analyzed by Kubios HRV corresponding software. The frequency domain indexes adopt FFT spectrum analysis method (window width: 256 s; window overlap: 50%). Time domain analysis indexes include standard deviation of the NN interval

(SDNN) and root mean square of SDS between adjacent NN intervals (RMSSD). Percentage of successful interval differences is larger than 50 ms (pNN50). Frequency domain analysis indicators include total power (TP), very low frequency (VLF), low frequency (LF), high frequency (HF), and ratio of low frequency to high frequency (LF/HF) [18].

3.3. Experimental Instruments. WBC, RBC, and Hb were measured by Beckman's three classification blood routine, and T and C were measured by Beckman access 2 automatic immune analyzer.

3.4. Pulse Artificial Intelligence Sensor Design. The precompetition training arrangement has a decisive influence on the competitive state of the athletes. Usually, the precompetition training will increase the load intensity and maintain or appropriately reduce the load amount. The artificial intelligence sensor technology is used to design the athlete training state pulse test system. The athlete training state pulse sensor is responsible for collecting the athlete training state pulse data. The athlete pulse sensor in this system adopts zn17-kg200 pulse vibration sensor as the pulse sampling sensor [19]. The athlete training state pulse sensor is responsible for collecting the athlete training state pulse data. The pulse sensor tests the dynamic pulse of each heartbeat of the human body. The A/D conversion is carried out through the vibration sensing information processing chip, and the human pulse signal adopted by the SA node of the pulse sensor is converted into an electrical signal. The generated current flows from the SA node of the right atrium to the following two ventricles, and the pulse map of the exercise training state is output through the I/O interface (D/A, a/D, I/O port, etc.). The technical indexes of the pulse acquisition sensor used in this paper are as follows.

Output voltage range: 0~3 MV/42~212 bmp.

D/A resolution of pulse sensor: 0.021 MV/2 bmp.

It has general equipment interface and I/O interface, the main frequency is 533 MHz, and the detection magnification of the output signal is 500.

3.5. Modular Design of Hardware Circuit. According to the selection of peripheral devices and sensor design of the above hardware circuit, the hardware circuit modular design of the whole athlete training state pulse test system is carried out. The design of amplification circuit, filter circuit, and pulse test control circuit of the system is described as follows.

3.5.1. Amplifier Circuit Design. The amplification circuit mainly amplifies the pulse test signal of athletes in training state and amplifies the output pulse sampling pulse signal of 0~5 MV to the range of 0~5 V. The A/D input of the later stage is realized through the external crystal and the internal oscillation circuit. Through the amplification circuit design, the output voltage meets the technical design index of the system, and the active crystal oscillator is used as the internal clock of the system to sample the abnormal characteristics of the pulse. By filtering and matching the voltage range, the magnification is 1000

times. Divide the voltage through R14 and R13, and complete the signal in two stages. The front stage realizes 20 times amplification, and the rear stage realizes 50 times amplification. When the switch S1 is pressed, the reset output is generated, and the amplification circuit design of the pulse test instrument designed in this paper is obtained. VSS and VCC are grounded and 3.3 V power supply, respectively, capacitors CD1 and CD2 are used to realize power filtering, SPI serial boot +2.5 V is a single power supply for bias amplification [20].

3.5.2. Filter Circuit Design. The normal heartbeat frequency of human body is about 60~100 times/min in the pulse test; it is easy to produce noise interference, which needs to be processed through the filter circuit. After passing through a 0 resistor, it is used as the I/O power supply to filter the noise. The filter is designed by setting the filter delay of the received and transmitted pulse test data through (R/x) DAT-DLY. In the filter circuit design, the dam controller reads/writes the DRR, designs a low-pass filter with the cutoff frequency above 20 Hz, takes the modulated signal output by the filter as the communication window when the DSP receives PC information, and transmits the sampling data of pulse sensing information between the two DSPs. Considering the redundancy design, in the filter design, the system adopts 50 MHz reference clock input. Through DSP interrupt control to read and write each chip and lock the chip selection signal, the filter circuit design is obtained.

Among them, $C_{F3} = 0.01 \mu\text{F}$ and $C_{F4} = 10 \mu\text{F}$ are electromagnetic interference and noise interference capacitance, respectively, taking $R_{F1} = R_{F2} = 50 \text{ k}\Omega$, $C_{F2} = 0.1 \mu\text{F}$. Different DC-DC chips are selected to control the maximum current output of the filter, then the gain of the filter is $-R_{F2}/R_{F1} = -1$, the cos signal is formed through the low-pass filter, and the cutoff frequency of the FIR filter is $1/(2\pi \cdot R_{F2} \cdot C_{F2}) = 31.83 \text{ Hz}$, which meets the filtering characteristic requirements of the athlete training state pulse test system [21].

3.5.3. Control Circuit. The control circuit is the information processing and integrated control of the pulse tester. It is the core of the whole system. PCI bus technology is used for characteristic sampling and signal analysis of pulse test data. The sampling width is 16 bits. The working frequency of the pulse tester in athletes' training state is 8 MHz, the single output is +3.3 V and +1.6 V, and the maximum current output is 1 A. The control circuit uses a group of external power supply 12 V for system power supply and uses TCP/IP protocol for communication to obtain the design of pulse test control circuit [22].

In the design of the main control chip of the pulse tester, the core processor adopts Samsung s3c6410a. The data line width of the pulse tester in athletes' training state is 8 bits. The distortion drift of the analog signal preprocessor is compensated by the designed band-pass filter. According to the automatic gain control, the loop reactance and power amplification gain of the pulse tester in training state are,

respectively,

$$\begin{aligned}\phi_0 &= \tan^{-1} \frac{B}{G}, \\ \phi_X &= \tan^{-1} \frac{Z_X}{R'_L} = \tan^{-1} [Z_L \cdot G \cdot (1 + \tan^2 \phi_0) - \tan \phi_0], \\ P_L &= V_0^2 \cdot G_X = V_0^2 \cdot G \times \frac{1 + \tan^2 \phi_0}{1 + \tan^2 \phi_X}.\end{aligned}\quad (1)$$

The single-frequency pulse signal of the pulse is output through the custom bus scsi-68, and the control signal output power supply of the relay is preprocessed to analyze the characteristics of the pulse signal and overload monitoring. Through the scsi-68 feedback dynamic gain control, the power transmission efficiency of the amplitude modulation emission of the pulse tester in athletes' training state is $\eta_e = 0.56$, $\eta_D = P_D/P_E = 0.44$. Adm706sar is programmed by CPLD to control the output gain of the pulse tester, and the ADC2 sampling circuit of ATmega128L is designed to sample the pulse characteristic sequence. To sum up, the whole hardware circuit design is obtained.

3.6. Data Statistics. SPSS 22.0 statistical software was used for the experimental test data. Paired sample *t*-test was used for the comparison of each index before and after. $P < 0.05$ and $P < 0.01$ were statistically significant.

4. Results and Analysis

4.1. Test Results of Physiological and Biochemical Indexes. After 4-week precompetition heavy load training, *T* and *T/C* of athletes decreased significantly compared with those before training ($P < 0.01$), which decreased by 37.99% and 52.69%, respectively, and the morning pulse increased significantly compared with that before training ($P < 0.05$), with an increase range of 32.39% and 20.39%. The changes of WBC, RBC, and Hb were not statistically significant ($P > 0.05$). See Table 2 and Figure 2.

The performance of the athlete training state pulse test system is designed in this paper. In the experiment, athletes carry the designed portable athlete training state pulse test for heavy load training and display the current training state pulse data of each athlete in real time, as shown in Figure 3. It can be seen from Figure 3 that the system designed in this paper can monitor the pulse information of athletes in the training state in real time, with good real-time results and accuracy, and can realize the abnormal pulse alarm, which has a certain practical value.

4.2. Sports Psychology Indicators. After 4-week precompetition heavy load training, the athletes' sense of achievement of ABQ index decreased, the negative evaluation of sports and the *z*-weighted total score of psychological fatigue increased significantly compared with that before training ($P < 0.05$, $P < 0.05$, and $P < 0.01$), and the degree of athletes' sports psychological fatigue increased significantly, as shown in Table 3.

In this study, lnLF and LF/HF were significantly increased, indicating that the sympathetic nervous system activity and tension increased after heavy-duty training in boxers, and the imbalance of sympathetic and parasympathetic nerves tended to favor sympathetic nerve activity.

4.3. Change Results of HRV Index. The HRV indexes lnLF and LF/HF of athletes after a 4-week precompetition heavy load training were significantly higher than those before training ($P < 0.05$). lnTP, lnHF, lnSDNN, lnRMSSD, lnPNN50, and lnVLF had no statistical significance compared with those before training ($P > 0.05$). See Figures 4 and 5.

4.4. Effect of Heavy Load Training before Competition on Physiological and Biochemical Indexes. Monitoring exercise fatigue by physiological and biochemical indexes is a scientific research method often used by sports science and technology workers. According to the mechanism of exercise fatigue, the diagnostic methods of exercise fatigue are summarized from the aspects of blood, endocrine, and metabolism. The changes of biochemical indexes such as HB decrease by 10%~15%, *T* decrease by 15%~20%, *C* increase by about 20%, and *T/C* decrease are used to diagnose exercise fatigue. This study shows that boxers' *T* and *T/C* decreased significantly after a 4-week prematch heavy load training, and *C* and morning pulse increased significantly. As for the changes of physiological and biochemical indexes in the state of exercise fatigue, most studies believe that after long-term heavy load training, *T* decreases, *C* increases, *T/C* ratio decreases, and morning pulse increases, which is manifested in the weakening of anabolism, the enhancement of catabolism is greater than anabolism, and the ability of the heart to bear the training load decreases. Catabolism and increased sympathetic tension lead to increased morning pulse and decreased ability of the heart to bear training load [23].

4.5. Influence of Heavy Load Training before Weekly Competition on ABQ. Athletes' long-time training with heavy load and monotonous repetition will cause sports psychological fatigue. The causes of sports psychological fatigue mainly include cognition, personality, age, social support, environment, training, competition, and project characteristics. At different stages of the training cycle, the proportion of the three components of sports psychological fatigue changed; "emotional and physical exhaustion" and "negative evaluation of sports" increased during the competition period, while the "sense of sports achievement" decreased during the competition period. During the fatigue period, the three components of exercise-induced psychological fatigue of cyclists reached the highest value. When volleyball players have psychological fatigue, the scores of "reduced sense of achievement" and "negative evaluation of sports" are medium, and the scores of "emotional/physical exhaustion" are high. In the above research, the three components of sports psychological fatigue show different changes, which are mainly related to different causes and project characteristics. In this study, after a 4-week prematch heavy load training, "sense of achievement

TABLE 2: Changes of physiological and biochemical indexes of boxers.

	Before heavy load training	After heavy load training	Descent rate (-)% Rise rate (+)%
WBC ($10^9 \cdot L^{-1}$)			
RBC ($10^{12} \cdot L^{-1}$)	5.06 ± 1.22	5.46 ± 1.66	7.88
Hb ($g \cdot dL^{-1}$)	4.90 ± 0.32	4.87 ± 0.27	-1.03
T ($ng \cdot dL^{-1}$)	15.21 ± 0.57	14.72 ± 0.61	-3.08
C ($\mu g \cdot dL^{-1}$)	636.91 ± 15.55	394.94 ± 81.45	-37.98
T/C	11.51 ± 1.72	15.25 ± 2.36	32.48
Morning pulse ($b \cdot min^{-1}$)	56.01 ± 5.91	26.54 ± 7.63	-52.67

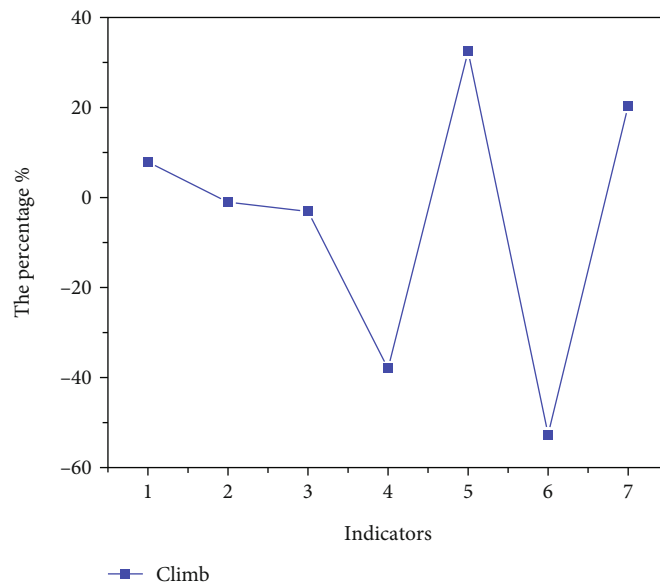

FIGURE 2: Physiological and biochemical indexes of boxers.

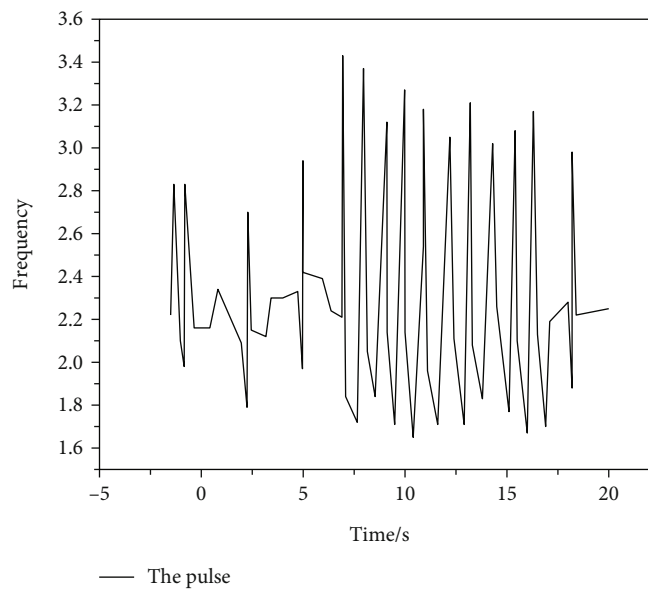

FIGURE 3: Pulse test results of athletes in training state.

TABLE 3: Changes of ABQ indexes of boxers.

	Before heavy load training	After heavy load training
Reduced sense of achievement	12.32 ± 1.36	14.01 ± 1.54
Emotional/physical exhaustion	11.51 ± 3.44	13.16 ± 2.41
Negative evaluation of sports	8.34 ± 2.33	11.51 ± 1.23
z-weighted total score of psychological fatigue	-0.27 ± 0.42	0.35 ± 0.26

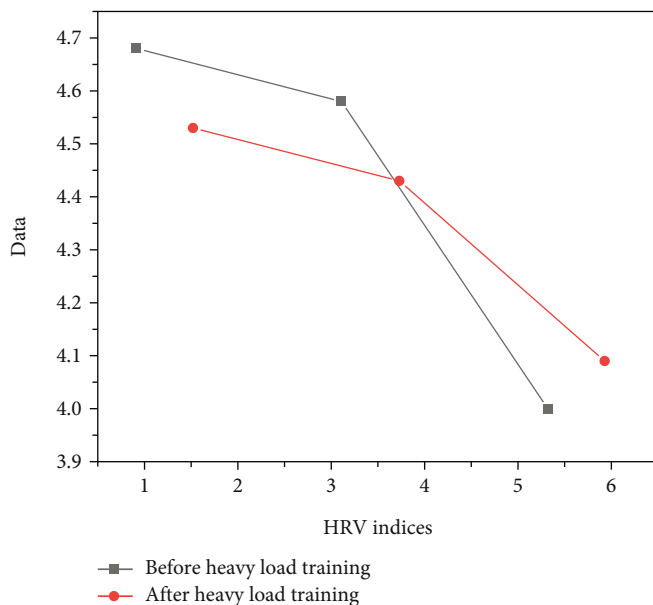

FIGURE 4: Changes of HRV time domain indexes of boxers.

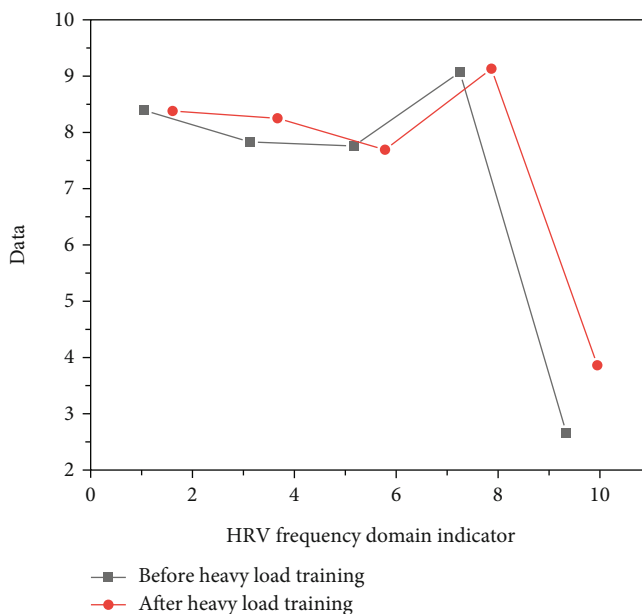

FIGURE 5: Changes of HRV frequency domain indexes of boxers.

decreased,” “negative evaluation of sports” and “z-weighted total score of psychological fatigue” increased significantly, and the degree of psychological fatigue of athletes increased.

The reason may be the stimulation of boxers after a long pre-match heavy load training. Coaches have increased the intensity, density, and difficulty of special technical movements.

Athletes have to bear the pressure from weight loss to complete training tasks, which reduces athletes' sense of self-efficacy and sense of achievement and increases sports psychological fatigue. The increase of psychological fatigue of boxers may also be related to psychological stress, age, and training years [24].

4.6. Effect of Heavy Load Training on HRV before Weekly Competition. HRV is sensitive to the functional changes of the autonomic nervous system and changes with the increase of training load. The test and analysis of HRV after exercise can reflect the adaptation of the cardiac autonomic nervous system to exercise. It is often used to diagnose exercise-induced fatigue, judge the training effect, and prevent overtraining. Under the condition of exercise fatigue caused by one-time exhaustive exercise, TP, LF, HF, and LF/HF decreased significantly, and the changes of parasympathetic nerve tension and sympathetic nerve tension decreased, accompanied by the imbalance of the sympathetic nerve and vagus nerve [25].

5. Conclusion

In this paper, the research on multisign health monitoring technology of athletes based on artificial intelligence is proposed, and a pulse test method of athletes' training state based on sensor technology is designed. The interference is processed through filter circuit. In the design of hardware module, the signal conditioning circuit is designed to amplify and filter the pulse test signal, and the pulse of athletes' training state is output in real time. Six elite boxers were selected as subjects. The elbow venous blood was collected on an empty stomach the next morning before and after the adjustment rest of the 4-week precompetition training stage. The concentrations of leukocytes, erythrocytes, hemoglobin, serum testosterone, and cortisol were measured. The morning pulse and heart rate variability after waking up were measured on the day of blood collection, and the exercise psychological fatigue questionnaire (ABQ) was filled out after breakfast. The results showed that serum testosterone and the ratio of testosterone to cortisol decreased significantly after a 4-week precompetition heavy load training, and serum cortisol and morning pulse increased significantly. The analysis of heart rate variability showed that lnLF and LF/HF increased significantly after the 4-week precompetition heavy load training ($P < 0.05$). The test results show that the pulse tester has good test performance and high application value. After four weeks of prematch heavy load training, the body sports fatigue of excellent boxers is characterized by less anabolism than catabolism, and the heart's ability to bear the training load is reduced. The intensification of sports psychological fatigue is characterized by reduced sense of achievement and increased negative evaluation of sports. The increase of lnLF and LF/HF suggests that the imbalance of sympathetic and parasympathetic nerves tends to be dominated by sympathetic activities. The combination of physiological, biochemical, and psychological indexes with HRV can comprehensively monitor the sports fatigue of boxing. In

this study, lnLF and LF/HF increased significantly, indicating that the activity and tension of sympathetic nervous system increased after heavy load training, and the imbalance of sympathetic nerve and parasympathetic nerve tended to be dominated by sympathetic nerve activity. The change of LF/HF was basically the same as the above research results. The no change of lnHF and the increase of lnLF are inconsistent with the above research results. It is analyzed that the reason may be related to the different research objects, project characteristics, and training schemes, as well as the different degrees of exercise fatigue caused by short-term training stimulation and long-term heavy load training stimulation, which needs to be verified by more in-depth research.

Data Availability

The data used to support the findings of this study are available from the corresponding author upon request.

Conflicts of Interest

The authors declare that they have no conflicts of interest.

Acknowledgments

The study is supported by the 2019 Special Scientific Research Plan of the Education Department of Shaanxi Province Project 19JK0276.

References

- [1] J. Wang, J. Guo, H. Li, Y. Deng, and J. Lu, "Research of omnidirectional measurement method to detect the errors of multi-axis numerical control machine tool based on laser tracker," *Iet Science Measurement & Technology*, vol. 12, no. 3, pp. 418–425, 2018.
- [2] W. Y. F. Xie, H. R. Y. Wang, and J. Ding, "Research on medical-health cloud computing technology based on big data," *Basic & Clinical Pharmacology & Toxicology*, vol. 118, Supplement 1, pp. 46–46, 2016.
- [3] S. Liu, Y. Piao, and M. Tahir, "Research on fusion technology based on low-light visible image and infrared image," *Optical Engineering*, vol. 55, no. 12, article 123104, 2016.
- [4] B. Kirubakaran and M. Ilankumaran, "Selection of optimum maintenance strategy based on fahp integrated with gra-top-sis," *Annals of Operations Research*, vol. 245, no. 1-2, pp. 285–313, 2016.
- [5] G. V. Sherbet, W. L. Woo, and S. Dlay, "Application of artificial intelligence-based technology in cancer management: a commentary on the deployment of artificial neural networks," *Anticancer Research*, vol. 38, no. 12, pp. 6607–6613, 2018.
- [6] P. Ye, Y. Cai, J. Bi, X. Yao, G. Li, and C. Yang, "Parasite egg recognition based on multicomponent cues by green-backed tits (*Parus monticolus*)," *Avian Biology Research*, vol. 15, no. 1, pp. 53–57, 2022.
- [7] Y. Yamanashi, "Translational research based on understanding the regulatory mechanisms of in vivo behaviors of fat-soluble compounds," *Yakugaku Zasshi*, vol. 139, no. 12, pp. 1485–1494, 2019.

- [8] N. Daroogheh, N. Meskin, and K. Khorasani, "Ensemble Kalman filters for state estimation and prediction of two-time scale nonlinear systems with application to gas turbine engines," *IEEE Transactions on Control Systems Technology*, vol. 27, no. 6, pp. 2565–2573, 2019.
- [9] H. Li, "Research on processing technology and design optimization of indoor soft packaging materials based on creation of artistic situation and influence of coastal climate," *Journal of Coastal Research*, vol. 115, no. sp1, p. 274, 2020.
- [10] W. Wei, Y. Zhang, and G. Wan, "Research on surface water quality in China-based on observation of 148 automatic monitoring stations," *Journal of Coastal Research*, vol. 115, no. sp1, p. 413, 2020.
- [11] A. C. Barchi, S. Ito, B. Escaramboni et al., "Artificial intelligence approach based on near-infrared spectral data for monitoring of solid-state fermentation," *Process Biochemistry*, vol. 51, no. 10, pp. 1338–1347, 2016.
- [12] L. Xiao, W. Shao, M. Yu, J. Ma, and C. Jin, "Research and application of a combined model based on multi-objective optimization for electrical load forecasting," *Energy*, vol. 119, pp. 1057–1074, 2017.
- [13] W. Kam, W. S. Mohammed, G. Leen et al., "Compact and low-cost optical fiber respiratory monitoring sensor based on intensity interrogation," *Journal of Lightwave Technology*, vol. 35, no. 20, pp. 4567–4573, 2017.
- [14] Y. Fu, C. Li, F. R. Yu, T. H. Luan, and Y. Zhang, "A survey of driving safety with sensing, vehicular coe," *IEEE Transactions on Intelligent Transportation Systems*, no. 99, pp. 1–22, 2021.
- [15] Z. An, X. Xu, J. Yang, Y. Liu, and Y. Yan, "Research of the three-dimensional tracking and registration method based on multiobjective constraints in an ar system," *Applied Optics*, vol. 57, no. 32, pp. 9625–9634, 2018.
- [16] Y. Fei, L. Ping, G. Ke, and Y. Bo, "Research progress of multi-scroll chaotic oscillators based on current-mode devices," *Optik*, vol. 127, no. 13, pp. 5486–5490, 2016.
- [17] T. Zhou, Z. Jiang, X. Liu, and K. Tan, "Research on the long-term and short-term forecasts of navigable river's water-level fluctuation based on the adaptive multilayer perceptron," *Journal of Hydrology*, vol. 591, no. 2, article 125285, 2020.
- [18] T. Zhang, W. Guo, W. Fan et al., "Acceleration mechanism and experimental research of multi-stage synchronous induction coilgun based on magnetic field arrangement," *IEEE Transactions on Plasma Science*, vol. 47, no. 10, pp. 4753–4759, 2019.
- [19] E. Beidler, T. Covassin, M. B. Donnellan, S. Nogle, M. B. Pontifex, and A. P. Kontos, "Higher risk-taking behavioursbehaviors and sensation seeking needs in collegiate student-athletes with a history of multiple sport-related concussions," *British Journal of Sports Medicine*, vol. 51, no. 11, p. A66.2-A66, 2017.
- [20] B. Carter, K. Whittaker, J. Dix, and C. Sanders, "G629 evaluating a telehealth project to support parental monitoring of signs of infection in children with neuropathic bladder," *Archives of Disease in Childhood*, vol. 101, Suppl 1, p. A371.1-A371, 2016.
- [21] M. N. Houston, M. C. Hoch, and J. M. Hoch, "Health-related quality of life in athletes: a systematic review with meta-analysis," *Journal of Athletic Training*, vol. 51, no. 6, pp. 442–453, 2016.
- [22] X. Xu, L. Li, and A. Sharma, "Controlling messy errors in virtual reconstruction of random sports image capture points for complex systems," *International Journal of Systems Assurance Engineering and Management*, 2021.
- [23] S. Shriram, J. Jaya, S. Shankar, and P. Ajay, "Deep learning-based real-time AI virtual mouse system using computer vision to avoid COVID-19 spread," *Journal of Healthcare Engineering*, vol. 2021, Article ID 8133076, 8 pages, 2021.
- [24] L. Xin, L. Jianqi, C. Jiayao, and Z. Fangchuan, "Mn₂O₃/γ-Al₂O₃ catalysts synergistic double dielectric barrier discharge (DDBD) degradation of toluene, ethyl-acetate and acetone," *Chemosphere*, vol. 284, article 131299, 2021.
- [25] R. Huang, S. Zhang, W. Zhang, and X. Yang, "Progress of zinc oxide-based nanocomposites in the textile industry," *IET Collaborative Intelligent Manufacturing*, vol. 3, no. 3, pp. 281–289, 2021.