

## Research Article

# Performance Analysis of Synchronous Multilink MAC Protocol with Automatic Repeat Request

Tong Jin , Jianlan Guo , Liangyu Lin , Yulei Wang , and Yungui Chen 

*The School of Computer Science and Engineering, The Faculty of Innovation Engineering, Macau University of Science and Technology, Avenida Wai Long, Taipa Macau, China*

Correspondence should be addressed to Jianlan Guo; rachel0519@126.com

Received 19 July 2022; Revised 29 August 2022; Accepted 5 September 2022; Published 27 September 2022

Academic Editor: Lingwei Xu

Copyright © 2022 Tong Jin et al. This is an open access article distributed under the Creative Commons Attribution License, which permits unrestricted use, distribution, and reproduction in any medium, provided the original work is properly cited.

Multilink operation (MLO) is considered a key candidate technique in 802.11be, which allows devices to transmit and receive data using multiple links concurrently, thereby contributing to improving throughput and reducing latency. However, the performance of the MLO scheme will gradually degrade as the channel environment deteriorates. To tackle this problem, in this paper, we propose a synchronous multilink media access control (MAC) protocol with Automatic Repeat Request (called SML-ARQ). With SML-ARQ, in the contention process, MLDs are allowed to perform channel access procedures over multiple links concurrently; in the transmission process, MLDs partition a link packet into multiple blocks and then transmit these blocks using multiple links. Any failed division of a link packet is copied and retransmitted once using multiple channels concurrently; as a consequence, SML-ARQ can mitigate the adverse impact of transmission failure on system performance. A theoretical model is being developed to analyze the performance of the proposed SML-ARQ. Extensive simulations verify the efficiency of SML-ARQ and the accuracy of our theoretical model.

## 1. Introduction

The wireless local area networking (WLAN) based on the IEEE 802.11 standard, frequently referred to as Wi-Fi, has become a necessity in both business and home environments [1]. According to a report issued by the Wireless Fidelity (Wi-Fi) Alliance [2], more than 9 billion Wi-Fi devices, including smartphones, laptops, tablets, IoT devices, and other devices, are currently in use worldwide. The emergence of new applications (e.g., augmented and virtual reality, video conference, gaming, and cloud computing) is entailing tremendous data traffic transiting over WLAN, demanding tens of gigabit per second data rates and sub 5 ms data transfer latency. To fulfill the peak throughput and stringent latency requirements set by future applications, the Institute of Electrical and Electronics Engineers (IEEE) 802.11 standard organization is going to release a new amendment standard, named IEEE 802.11be Extremely High Throughput (EHT) [3].

According to the 802.11be Project Authorization Request (PAR) approved by the IEEE Standards Board, 802.11be can offer a maximum throughput of at least 30 Gb/s [3] within a frequency range from 1 GHz to 7.25 GHz, while simultaneously improving worst case latency and jitter. For such purposes, 802.11be introduces various candidate significant techniques (such as single-band operation, multilink operation, spatial multiplexing, multiaccess point (multi-AP) coordination, and link adaptation) [2, 4–6].

The Multilink Operation (MLO) is one of the most representative main candidate techniques, which allows concurrent data transmission and reception between APs and stations (STAs) using multiple links. The AP/STA device (i.e., a single device with multiple affiliated AP/STAs) that can operate with multiple links is called AP/STA multilink capable devices (MLDs). There are two kinds of transmission modes, namely, asynchronous transmission mode and synchronous transmission mode [7], which can be supported in 802.11be. The former allows an MLD to transmit data frames asynchronously over different links. These

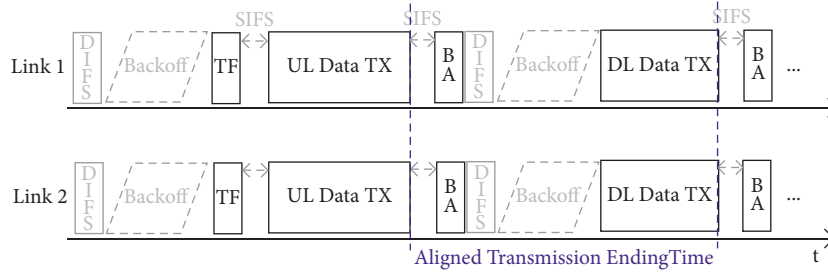

FIGURE 1: Synchronous transmission mode representation.

affiliated APs/STAs in this MLD can be regarded as multiple independent devices, and these devices can perform concurrent uplink and downlink transmission. Each affiliated AP/STA of an AP/STA STR MLD performs the channel access procedure independently over each link. MLD operating under asynchronous mode is called Simultaneously Transmit and Receive (STR) MLD. The latter allows an MLD to perform synchronized data frame transmissions on multiple links (by using the end time alignment or the defer transmission mechanism [8]). The MLD operating under the synchronous mode is called non-STR MLD. Since STR MLD usually provides poor performance due to the well-known in-device coexistence (IDC) interference, in this paper, we assume that all MLDs use synchronous transmission mode (see Figure 1).

*1.1. Motivation.* Potential benefits provided by MLO include (1) improving peak throughput by enabling opportunistic and efficient multilink channel access and allowing concurrent data transmission and reception over multiple frequency bands/channels; (2) reducing the end-to-end latency via seamless transitions among different links [2, 6, 9, 10].

However, [11, 12] evaluated the performance of the MLO scheme without retransmission in different channel environments (e.g., Rayleigh and Rician fading environments), which reveals that the potential gains provided by MLO in 802.11be can be decreased in bad channel conditions. Therefore, how to design the retransmission scheme utilizing multiple links to ensure reliable data transmission over noise wireless channels needs to be investigated.

*1.2. Our Contribution.* This paper aims to design a dynamic redundancy-based multilink retransmission scheme, which is suitable for the scenarios where each 802.11 device supports MLO. To the best of our knowledge, this paper is the first step toward designing a retransmission scheme to fully exploit the potential benefits of multiple links. This scheme can drastically alleviate system performance degradation caused by transmission failure in bad channel conditions. Our contributions are summarized as follows:

- (1) We propose a synchronous multilink MAC protocol with Automatic Repeat Request (called SML-ARQ). In the contention process, it allows MLDs to perform channel access procedures over multiple links independently and concurrently. Consequently,

compared to a single-link device, an MLD has more opportunities to access the channel than a single-link device. In the transmission process, it partitions a link packet into multiple blocks based on the number of available links of the MLD and then transmits these blocks concurrently using multiple links. If there is at least one block found to have failed after transmission, then those failed blocks will be retransmitted. In this way, the time taken by transmitting a link packet is shortened, and the negative impact of block errors can be efficiently mitigated.

- (2) We develop a theoretical model to analyze the system throughput of our protocol. With this model, we are able to evaluate the performance of the system.
- (3) We run extensive simulations to verify the accuracy of our theoretical model and demonstrate the superiority of our proposed protocol by comparing it with the synchronous multilink MAC protocol without a retransmission scheme (which is called SML-NARQ hereafter) in terms of system throughput. For example, adopting the same network environment (e.g., network topology, the number of available links, and fading environment), it is shown that there is up to 96.2% throughput gains achieved by using our protocol than that of using SML-NARQ.

## 2. Related Work

*2.1. Retransmission Scheme in IEEE 802.11 Standard.* In order to provide reliable data transmission, extensive research efforts have been dedicated to designing and implementing efficient ARQ schemes in wireless networks [13, 14]. Reference [15] designs a novel MAC-defined aggregated selective repeat ARQ scheme with the consideration of frame aggregation in the IEEE 802.11n standard and further proposes a Reed-Solomon (RS) block code-based aggregated hybrid ARQ scheme for achieving better performance under bad channel condition. Reference [16] proposes an adaptive ARQ scheme for aggregate MPDU transmission in the 802.11ac error-prone wireless network environment. Given the optimal parameter pairs (i.e., the number of lost MPDUs and the number of duplicated MPDUs) in duplicated MPDUs transmission, this protocol enhances system performance under worse channel quality.

Reference [17] proposes a QoS-aware backup padding ARQ Scheme suitable for multiuser (MU) transmission, which aims to solve the dummy bits problem and the blocking problem caused by failed packets; therefore, it can provide Quality of Service (QoS) guarantees.

However, most of the existing ARQ algorithms are designed and implemented in conventional 802.11 WLAN scenarios with multiple single-link devices. These designs allow retransmission using only one channel and therefore fail to fully utilize the potential gains of multiple channels in the scenarios where each device supports MLO.

### 2.2. Multiradio Multichannel Transmission in IEEE 802.11be.

Reference [2] gives a comprehensive review of the IEEE 802.11be and evaluates its potential throughput gains of it through system-level simulation results. This paper demonstrates that, by using various candidate significant techniques (such as single-band operation, multilink operation, and link adaption), 802.11be can achieve a remarkable performance improvement with respect to 802.11ax. As one of the most representative features proposed in 802.11be, multilink operation (MLO) offers great potential to enhance system throughput and has thus attracted significant attention [6, 18]. Several studies have been devoted to discussing how to design and implement efficient synchronous channel access schemes supporting MLO. Reference [19] proposes an enhanced channel access mechanism to facilitate multilink utilization. To mitigate the effect of the radio-frequency (RF) power leakage problems, various penalties will be assigned to multilink devices based on specific rules, thus guaranteeing high performance. Reference [20] first indicates the backoff counter overflow problem during the synchronous channel access process and then proposes available solutions to tackle the problem, thereby improving throughput and latency.

Nevertheless, none of these designs for multiradio multichannel transmission focus on designing the retransmission process utilizing the MLO functionality. In the case of bad channel conditions, the performance of these designs drops sharply due to frequent transmission failure.

In contrast, unlike the previous works, our proposed SML-ARQ allows MLDs to utilize multiple links for retransmission, thereby achieving more reliable transmissions within a shorter transmitting period. The remainder of the paper is organized as follows. Section 3 details the MAC layer design of SML-ARQ. Section 4 provides a theoretical model to analyze the system throughput. Section 5 provides the performance evaluation. Section 6 concludes this paper.

## 3. Mac Layer Design

In this section, we first outline the proposed SML-ARQ and then, respectively, detail the contention process and the retransmission process.

**3.1. Overview.** Inspired by the multiradio multichannel retransmission scheme specified in [21], we propose a distributed MAC protocol for IEEE 802.11be, called SML-ARQ,

by fully exploiting the potential gains of the MLO technique. With SML-ARQ, the goal of efficiently improving the network throughput and reducing latency is achieved.

As depicted in Figure 2(a), considering an infrastructure-based WLAN scenario with 1AP and  $v$  nodes, we introduce the proposed SML-ARQ protocol. In this paper, we assume that the system is saturated (each node is assumed to have consecutive uplink traffic flow).

The 802.11be allows MLDs to concurrently utilize multiple channels. For an MLD that possesses the STR mode, asynchronous transmissions can be operated independently on individual links. Each AP/STA that belongs to an AP MLD/non-AP MLD performs channel contention following IEEE 802.11 distributed coordination function (DCF) over different links independently. In this case, the throughput achieved by a STR mode  $n$ -link MLD can ideally be exactly  $n$  times that achieved by a legacy single-link device. The performance of STR mode MLD is better than that of non-STR mode MLD; however, to avoid the RF power leakage problem (i.e., the RF power leakage of one link ruins the transmission/reception on other links), we assume that all MLDs possess the non-STR mode and operate under the synchronous transmission mode.

Figure 2(b) shows an IEEE 802.11be  $n$ -link AP MLD and non-AP MLD. Each time the  $n$ -link non-AP MLD transmits an uplink link packet, this link packet will be divided into  $n$  blocks, and then each of these blocks will be transmitted over a respective link.

In SML-ARQ, all nodes execute two processes serially (as illustrated in Figure 3): the contention process and the dynamic transmission process (i.e., the transmission duration is variable).

In the contention process, each MLD first senses that the channel remains idle for DCF Interframe Space (DIFS) duration and then performs a channel access procedure following the multilink distributed coordination function (called ML-DCF).

In the transmission process, the MLD that infers that it has won the channel will instantaneously start a dynamic uplink synchronous transmission process with ARQ. Note that the ending time of a transmission performed by each of the affiliated STAs of the MLD is aligned.

**3.2. Contention Process.** Figure 4 depicts the contention process in SML-ARQ. For an  $n$ -link MLD, ML-DCF stipulates that each of  $n$  link can be designated as a channel access link (that is, each link has a separate backoff counter). An  $n$ -link MLD validates its victory when all of the backoff counters of  $n$  links reach zero, and afterwards, it will initiate an uplink data transmission process over  $n$  links simultaneously. Among  $n$  links, the latest one that has completed its backoff procedure will be set to Primary Link (PL), while the remaining  $n - 1$  links will be set to Auxiliary Link (AL).

Below, by taking an  $n$ -link MLD  $i$  as an example, we describe the design of the ML-DCF. As shown in Figure 4, suppose that the backoff counters selected by MLD  $i$  on link 2, link 3, ..., link  $n - 1$  are all less than or equal to 3, while the backoff counters of link 1 and link  $n$  are 4 and 3, respectively.

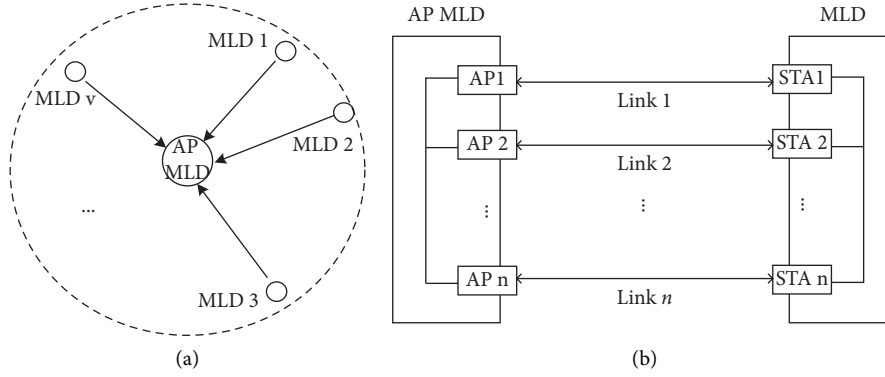

FIGURE 2: (a) The network topology and (b) IEEE 802.11be multilink devices with  $n$  links (where  $n \leq 4$ ).

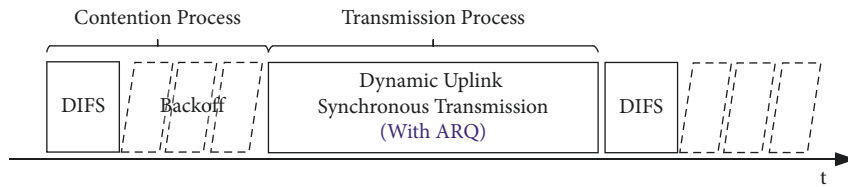

FIGURE 3: An overview of SML-ARQ design.

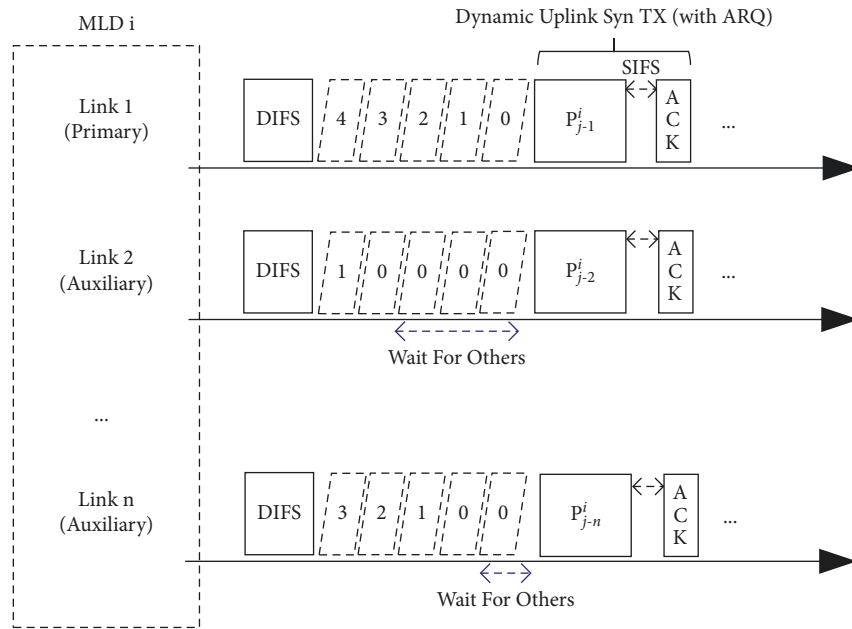

FIGURE 4: ML-DCF with the longest backoff of the MLD  $i (i \in [1, v])$  in the SML-ARQ, where  $n \leq 4$ .

Therefore, the other links have to wait until the backoff counter of link 1 expires. Here,  $P_{j-f}^i$  represents the  $f$ th block ( $f \in [1, n]$ ) of  $j$ th link packet transmitted by the MLD  $i$ . If each link of MLD  $i$  has received the acknowledgment frames (ACK) feedback (detailed in Section 3.3), then it will infer that the  $j$ th link packet has been received successfully by an AP MLD. In this case, the MLD  $i$  does not need to perform a retransmission process. Otherwise, if there is at least one link of MLD  $i$  that has received the negative-acknowledgement frames (NACK) feedback, MLD  $i$  will initiate a retransmission process (explained in Section 3.3). Note that the

ACK time (i.e., transmission times of the ACK) is set equal to the NACK time (i.e., transmission times of the NACK).

Since each link packet will be divided into  $n$  blocks and is thereby able to be transmitted concurrently utilizing  $n$  channels, the txSlot size in SML-ARQ is set equal to the period of time needed for transmitting a block.

**3.3. Retransmission Process.** In SML-ARQ, if the receiver (i.e., one affiliated AP) successfully receives a block on a link, then it will send the ACK feedback; otherwise, it will send the

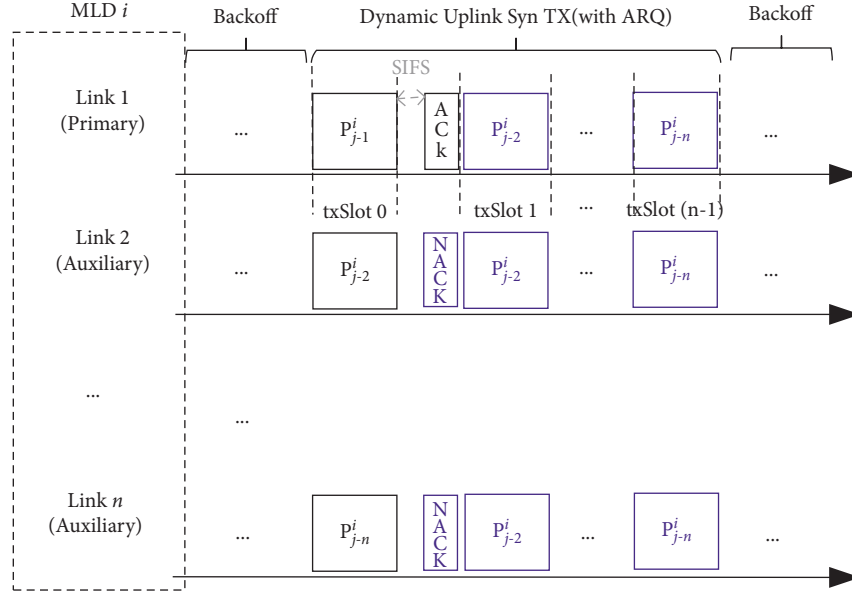

FIGURE 5: The retransmission process of the MLD  $i$  in the SML-ARQ (where the  $P_{j-f}^i$  ( $f \in [1, n]$ ) represents the  $f$ th block of the  $j$ th link packet and  $n \leq 4$ ).

NACK feedback. Based on the receiver feedback, as we mentioned before, if there is at least one block found to have failed after the first transmission slot (i.e., txSlot 0), then those failed blocks will be retransmitted according to a simple rule: each block that was found to have failed in the first transmission will be retransmitted for only one time, and at each retransmission, it will be duplicated to  $n$  copies for concurrently transmitting over  $n$  available links. For a link packet composed of  $n$  blocks, the order of retransmissions for possible failed blocks is indicated by their failed block indices. As depicted in Figure 5, the indices of failed blocks are  $2, \dots, n$ ; therefore,  $n$  copies of  $P_{j-2}^i, \dots, P_{j-n}^i$  will be sequentially transmitted in, respectively, txSlot 1,  $\dots$ , txSlot  $n-1$ .

Taking an  $n$ -link MLD  $i$  as an example, Figure 5 shows the retransmission process in SML-ARQ. Let  $P_{j-f}^i$  ( $f \in [1, n]$ ) denote the  $f$ th block of the  $j$ th link packet transmitted by MLD  $i$ . Assume that only link 1 of MLD  $i$  has received the ACK feedback, while its other links have received the NACK feedback. In this case, MLD  $i$  infers that the  $P_{j-1}^i$  (i.e., 1th block of  $j$ th link packet transmitted by MLD  $i$ ) is successfully received by AP MLD, while the other  $n-1$  blocks of  $j$ th link packet (i.e.,  $P_{j-2}^i, \dots, P_{j-n}^i$ ) all have failed after the first transmission slot. Therefore, MLD  $i$  sequentially transmits  $n$  copies of  $P_{j-2}^i, \dots, P_{j-n}^i$  using  $n$  links simultaneously in the retransmission process.

In case there is no block found to have failed after the txSlot 0, the uplink transmission process consists of one txSlot, a short interframe space (SIFS), and an ACK. In case there are  $k$  blocks found to have failed after the txSlot 0, the uplink transmission process consists of  $k+1$  txSlot, a SIFS, and an ACK/NACK. In the example in Figure 5, when the value of  $k$  is  $n-1$ , the time of the dynamic transmission process is the sum of  $n$  txSlots and an ACK/NACK time.

## 4. Theoretical Analysis

In this section, we develop theoretical models to analyze the system throughput of the proposed SML-ARQ. Assuming that the system is saturated (each node is assumed to have consecutive uplink traffic flow) in SML-ARQ, we first calculate the conditional collision probability (i.e.,  $p$ ) and the probability of the event that an STA of MLD transmits in a randomly selected slot (i.e.,  $\tau$ ) and then define and obtain the system throughput.

**4.1. The Probability  $p$  and the Probability  $\tau$ .** Let  $TX$  represent the event that an STA of an  $n$ -link MLD ( $n \in [1, 4]$ ) transmits in a randomly chosen slot time, and the probability of  $TX$  is denoted by  $P(TX)$ . Assume that  $s$  represents the backoff stage of an STA, and then  $s=i$  denotes the event that the backoff stage of the STA is  $i$  ( $i \in [0, R]$ ). Let  $R$  represent the maximum retry limit. According to Bayes' theorem in [9, 22], we have

$$P(TX) \cdot \frac{P(s=i|TX)}{P(TX|s=i)} = P(s=i), \quad (1)$$

where  $P(s=i|TX)$  refers to the conditional probability that the backoff stage of an STA is  $i$  assuming that this STA transmits in a randomly chosen slot time, while  $P(TX|s=i)$  refers to the conditional probability of an STA transmitting in a randomly chosen slot time assuming that the backoff stage of this STA is  $i$ .

For each  $i \in [0, R]$ , we have

$$P(TX) \cdot \sum_{i=0}^R \frac{P(s=i|TX)}{P(TX|s=i)} = \sum_{i=0}^R P(s=i) = 1. \quad (2)$$

Then, the  $\tau$  can be expressed as

$$P(TX) = \tau = \frac{1}{\sum_{i=0}^R P(s=i|TX)/P(TX|s=i)}. \quad (3)$$

Let  $\nu$  represent the total number of  $n$ -link MLDs. Following [23], the conditional collision probability  $p$  is the probability that a transmitted link packet collides, which can be expressed as

$$p = 1 - (1 - \tau)^{\nu-1}. \quad (4)$$

Thus, to compute  $\tau$ , we first calculate  $P(s=i|TX)$  and  $P(TX|s=i)$ .

For  $P(s=i|TX)$ , it follows a truncated geometric distribution, with parameters  $1-p$  and  $R+1$  [22]; thus, we have

$$P(s=i|TX) = \frac{(1-p)p^i}{1-p^{R+1}}. \quad (5)$$

For  $P(TX|s=i)$ , it is calculated according to [22]

$$P(TX|s=i) = \frac{1}{1+E[b_i]}, \quad (6)$$

where  $E[b_i]$  represents the average value of the chosen backoff counter on each link of an  $n$ -link MLD, when its current backoff stage is  $i$ .

Besides, we calculate the  $E[b_i]$ . Let discrete r.v.  $X_{n,i}$  represent the chosen backoff counter on link  $n$  of an  $n$ -link MLD after a successful link packet transmission or after a collision when the backoff stage of STA on link  $n$  is  $i$ . The range of  $X_{n,i}$  is given by

$$X_{n,i} \in [0, W_i - 1], \quad (7)$$

where  $W_i = 2^i CW_{\min}$ .

The chosen backoff counters on each link of an  $n$ -link MLD are independent and identically distributed (i.i.d.) from a uniform distribution over  $(0, W_i - 1)$

$$X_{1,i}, X_{2,i}, \dots, X_{n,i} \sim \text{Uniform}(0, W_i - 1). \quad (8)$$

For  $r \in [1, m]$ ,  $x \in [0, W_i - 1]$ , we have

$$P_{X_{r,i}}(x) = P(X_{r,i} = x) = \frac{1}{W_i}. \quad (9)$$

Let discrete r.v.  $Y_{n,i}$  represent the largest one of  $n$  chosen backoff counters of  $n$ -link MLD when its corresponding backoff stage is  $i$ , i.e.,

$$Y_{n,i} = \max(X_{1,i}, X_{2,i}, \dots, X_{n,i}). \quad (10)$$

Let  $c$  represent a constant value ( $c \in [0, W_i - 1]$ ), and then, the cumulative distribution function of  $Y_{n,i}$  can be expressed as

$$\begin{aligned} P(Y_{n,i} \leq c) &= P(X_{1,i} \leq c, X_{2,i} \leq c, \dots, X_{n,i} \leq c) \\ &= P(X_{1,i} \leq c)P(X_{2,i} \leq c) \dots P(X_{n,i} \leq c) = \left(\frac{c+1}{W_i}\right)^n. \end{aligned} \quad (11)$$

Using (11), we see that

$$\begin{aligned} P(Y_{n,i} = c) &= P(Y_{n,i} \leq c) - P(Y_{n,i} \leq c-1) \\ &= \left(\frac{c+1}{W_i}\right)^n - \left(\frac{c}{W_i}\right)^n. \end{aligned} \quad (12)$$

By substituting (12) in (6), we obtain

$$\begin{aligned} P(TX|s=i) &= \frac{1}{1+E[b_i]} \\ &= \frac{1}{1 + \sum_{c=0}^{W_i-1} c \cdot P(Y_{n,i} = c)} \\ &= \frac{1}{1 + \sum_{c=0}^{W_i-1} c \cdot ((c+1/W_i)^n - (c/W_i)^n)}, \end{aligned} \quad (13)$$

where  $n \in [1, 4]$ ,  $i \in [0, R]$ , and  $c \in [0, W_i - 1]$ .

Finally, by substituting (5) and (13) in (3), we obtain the expression of  $\tau$  with  $p$  as a parameter. This expression and (4) represent a nonlinear system, which can be solved using fixed point iteration, and the numerical results of  $\tau$  and  $p$  can be obtained.

**4.2. Throughput Efficiency.** Let  $S$  denote the normalized system throughput, defined as the ratio of the MAC Layer throughput and the data rate. Let  $\Gamma$  and  $R$  denote the MAC Layer throughput and the data rate, respectively, and we have

$$S = \frac{\Gamma}{R}. \quad (14)$$

Here, the MAC Layer throughput  $\Gamma$  is defined as the average number of uplink bits transmitted successfully in the average length of a generic slot time  $\Omega$ , i.e.,

$$\Gamma = \frac{P_s P_{tr} \bar{L}_p}{E(\Omega)}, \quad (15)$$

where  $P_s$  denotes that a successful transmission occurs after contention stage (i.e., the probability that exactly one  $n$ -link MLD transmits a link packet on the channel), the probability that at least one  $n$ -link MLD attempts to transmit in a generic slot time, and the average payload size of a successfully received link packet (i.e., when a link packet error does not occur).

According to [23], the  $P_{tr}$  and  $P_s$  are given by

$$\begin{aligned} P_{tr} &= 1 - (1 - \tau)^\nu, \\ P_s &= \frac{n\tau(1 - \tau)^{\nu-1}}{1 - (1 - \tau)^\nu}. \end{aligned} \quad (16)$$

Below, to calculate  $\bar{L}_p$ , we first calculate the average block error rate, which is denoted as  $\bar{P}_{be}$ . Let  $b$  represent the length of each block that is transmitted in one link of  $n$ -link MLD, and we have

$$b = L_{phy} + L_{mac} + \frac{1}{n}L_{payload}. \quad (17)$$

Assuming that  $n$  links can all be regarded as identical but independent Nakagami-slow-fading channels corrupted by independent additive white Gaussian noise, let  $\gamma$  ( $\gamma > 0$ ) represent the instantaneous SNR per bit, considering using M-ary QAM in Nakagami-  $m$  ( $m \geq 1/2$ ) slow-fading channels, following [21], and  $\overline{P_{be}}$  is given by

$$\overline{P_{be}} = \int_0^{\infty} P(\gamma) (1 - (1 - \epsilon_{ins}(\gamma))^b) d\gamma, \quad (18)$$

where  $\epsilon_{ins}(\gamma)$  represents the instantaneous bit error rate (BER) conditional on  $\gamma$  given in [24, 25];  $P(\gamma)$  represents the probability density function (pdf) of instantaneous signal-to-noise ratio (SNR) per bit that was driven in [26], which is given by

$$P(\gamma) = \frac{m^m \gamma^{m-1} e^{-m\gamma/\overline{\gamma_c}}}{\overline{\gamma_c}^m \Gamma(m)}, \quad (19)$$

where  $\Gamma(\bullet)$  represents the Gamma function, and  $\overline{\gamma_c}$  denotes the average SNR per bit.

Since the average block success rate is equal to  $1 - \overline{P_{be}} \in [0, 1]$ , let r.v.  $T$  follow a binomial distribution with parameters  $n$  and  $\overline{P_{be}}$ ; thus, we have

$$T \sim Bn, 1 - \overline{P_{be}}. \quad (20)$$

Let  $T = kk \in [0, n]$  represent the event that, within one txSlot, there are exactly  $k$  blocks that are successfully received in  $n$  blocks transmitted by an  $n$ -link MLD. Then, the probability of  $T = k$  is expressed as

$$P_r(T = k) = \binom{n}{k} (1 - \overline{P_{be}})^k \overline{P_{be}}^{n-k}. \quad (21)$$

Then,  $\overline{L_p}$  can be calculated as

$$\overline{L_p} = E(T_p) = \left( P_r(T = n) + \sum_{i=0}^{n-1} P_r(T = i) \sum_{j=1}^n P_r(T = j)^{n-i} \right) \bullet L_{payload}. \quad (22)$$

Finally, we compute the  $E(\Omega)$ . Let  $\sigma$  denote the duration of an empty slot time in 802.11, and let  $\sigma_1$  represent/denote the duration of a txSlot ( $\sigma_1 = T_{phy} + T_{mac} + 1/nT_{payload}$ ). We can calculate  $\Omega$  as follows:

$$\Omega = \begin{cases} T_{difs} + \overline{T_s}, & w.p.P_{tr}P_s, \\ T_{difs} + T_c, & w.p.P_{tr}(1 - P_s), \\ \sigma, & w.p.1 - P_{tr}. \end{cases} \quad (23)$$

Hence,  $E(\Omega)$  can be expressed as

$$E(\Omega) = (1 - P_{tr})\sigma + P_{tr}P_s(T_{difs} + \overline{T_s}) + P_{tr}(1 - P_s)(T_{difs} + T_c), \quad (24)$$

where  $T_c$  represents the duration of a collision (i.e., the channel is unavailable for a while due to an unsuccessful link

TABLE 1: Parameter settings in simulation.

$v$	30	Slot	9 $\mu s$
$T_{DIFS}$	34 $\mu s$	m	1/2
$T_{SIFS}$	16 $\mu s$	R	135 Mbps

packet transmission),  $T_c = (n + 1)\sigma_1 + T_{sifs} + T_{nack}$ , while  $\overline{T_s}$  represents the average time the channel is sensed busy due to a successful link packet transmission.

Let  $T_{ack/Nack}$  represent the transmission times of the ACK/NACK frame (where we assume that the length of the ACK/NACK frame is equal); thus,  $\overline{T_s}$  can be calculated as

$$\overline{T_s} = E(T_s) = \sum_{i=0}^n P_r(T = i) t_{s_i}, \quad (25)$$

$$t_{s_i} = (n - i + 1)\sigma_1 + T_{sifs} + T_{ack/Nack}$$

where  $t_{s_i}$  refers to the duration of the transmission process given that there are exactly  $i$  blocks that are successfully received in  $n$  blocks transmitted by an  $n$ -link MLD after the first txSlot.

## 5. Performance Evaluation

In this section, we evaluate the performance of SML-ARQ protocol via extensive simulations. Besides, we compare our protocol with the SML-NARQ protocol.

For SML-ARQ, the theoretical throughput efficiency is calculated according to (14); and the SML-ARQ simulator is written using C++. Table 1 shows the default parameter settings in our protocols and the SML-NARQ. The number of nodes  $v$  is set equal to 30 by default. The slot time size, the distributed coordination function interframe space (DIFS), and the SIFS are set equal to 9  $\mu s$ , 34  $\mu s$ , and 16  $\mu s$ , respectively, which are set in accordance with IEEE 802.11be. In this paper, we consider Nakagami-1/2 slow-fading environments. The data rate is set to 54 Mbps. The length of the MAC payload is 1080 Bytes. The value of each simulation result is an average of over 5 simulation runs, where each run lasts for 100 seconds.

In Figures 6–10, curves with labels “ana” and “sim” denote the theoretical and simulation results, respectively; curves labeled “( $n = 1$ ”, “( $n = 2$ ”, “( $n = 3$ ”, and “( $n = 4$ ” represent the results of  $n$ -link SML-ARQ when  $n$  is equal to 1, 2, 3, and 4, respectively. In Figures 6 and 7, curves labeled “( $c = 1$ ”, “( $c = 2$ ”, “( $c = 3$ ”, and “( $c = 4$ ” represent the simulation results of  $n$ -link SML-NARQ when  $n$  is equal to 1, 2, 3, and 4, respectively.

Figure 6 plots the normalized throughput efficiency of SML-ARQ and SML-NARQ as the number of nodes varies from 2 to 50, when setting SNR= 12dB and 16-QAM. From this figure, we have the following four observations.

- (1) For our protocol, the simulation curves almost overlap the corresponding theoretical curves from (14); the average relative error between them is 1.8%, which demonstrates that our model is very accurate.
- (2) The system efficiency in our protocol is higher than that in the compared protocol. In total, there are

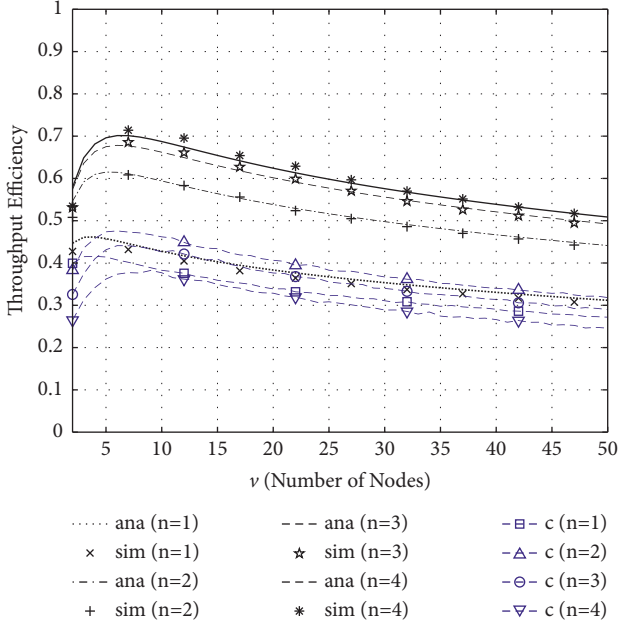
FIGURE 6: Throughput efficiency versus  $\nu$ .

approximately 34.0% and 96.2% throughput gain achievable by 2-link SML-ARQ and 4-link SML-ARQ compared to 2-link SML-NARQ and 4-link SML-NARQ, respectively. It is obvious in the figure that the improvement in channel utilization is proportional to the number of links (say, the larger the  $n$ , the higher the  $n$ -link SML-ARQ system efficiency). This is because, for one thing, the  $n$ -link SML design fully exploits potential gains of  $n$ -link compared with a single-link device. Specifically, it can (1) increase channel access efficiency (i.e., there are far more opportunities to access the channel); (2) shorten the time taken by transmitting a link packet. For another reason, the ARQ mechanism effectively mitigates the negative impact of block errors. Recalling the ARQ design, if a block error occurs on a specific link in the first txSlot, the failed block will be copied  $n$  times, and then, these  $n$  copies will be, respectively, retransmitted on each of the  $n$  links. In the retransmission process, the probability that all  $n$  copies will fail is low. Consequently, our design can significantly improve system performance.

- (3) The system throughput efficiency in 2-link SML-NARQ exceeds the system throughput efficiency of 3-link SML-NARQ and 4-link SML-NARQ, and the system throughput efficiency of 4-link SML-NARQ is even slightly lower than that of 1-link SML-NARQ. The reason is that, in  $n$ -link SML-NARQ, a link packet is divided into  $n$  blocks, and these  $n$  blocks are transmitted concurrently on  $n$  links, respectively. In the absence of a retransmission scheme, if and only if all  $n$  blocks have been successfully transmitted (that is, no block error has ever occurred on these  $n$  links), the link packet composed of those  $n$  blocks can be regarded as successfully received by the receiver.

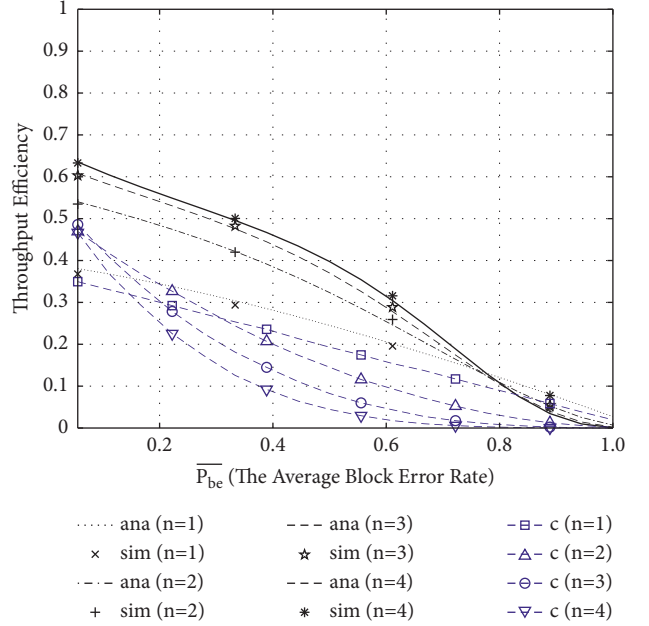
FIGURE 7: Throughput efficiency versus  $\overline{P_{be}}$ .

Under the poor channel conditions, the probability of a link packet being successfully received by the receiver is low when using SML-NARQ. Although SML-ARQ significantly shortens the duration of a link packet transmission, frequent occurrence of block errors will offset the gains offered by multilinks.

- (4) For both SML-ARQ and SML-NARQ, the throughput efficiency decreases slightly as  $\nu$  increases. The reason is that as the number of nodes participating in the contention increases, collisions caused by two or more nodes choosing identical backoff counters are prone to occur.

Figure 7 plots the normalized throughput efficiency of SML-ARQ and SML-NARQ as the average block error rate varies from 0.0 to 1.0 when setting  $\nu = 30$ . In this figure, we can see that:

- (1) For our protocol, the theoretical results well match the corresponding simulation results; the average relative error between them is 1.7%, meaning that our theoretical model is very accurate.
- (2) For both SML-ARQ and SML-NARQ, the normalized throughput efficiency decreases as  $\overline{P_{be}}$  increases. This indicates that the system performance of using either of these two protocols is severely affected by the channel environment. The worse the channel environment, the lower the performance of SML-ARQ and SML-NARQ.
- (3) The throughput efficiency in SML-NARQ is almost always lower than that in SML-ARQ. In the case of  $\overline{P_{be}} \geq 0.09$ ,  $\overline{P_{be}} \geq 0.15$ , and  $\overline{P_{be}} \geq 0.26$ , the throughput efficiency of 4-link SML-NARQ, 3-link SML-NARQ, and 2-link SML-NARQ, respectively, is lower than



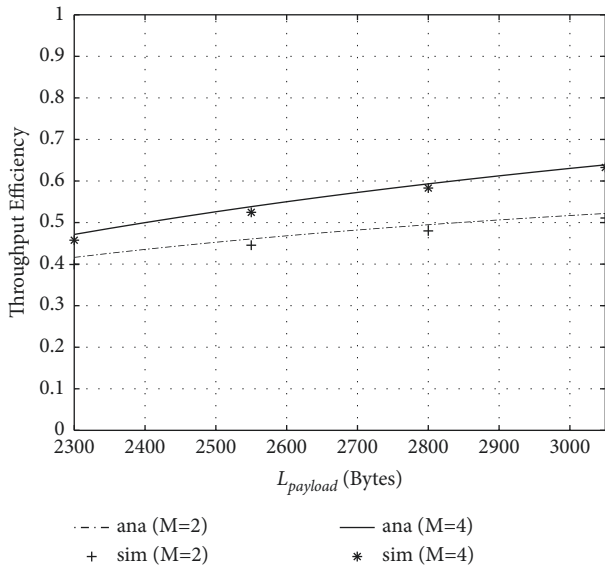

FIGURE 8: Throughput efficiency versus payload length.

that of 1-link SML-NARQ. This indicates that, for  $n$ -link SML-NARQ, once  $\overline{P}_{be}$  exceeds a certain value, frequent block errors in turn severely reduce the throughput gain provided by multi-link. The performance of using  $n$ -link SML-NARQ is inversely proportional to  $n$  as  $\overline{P}_{be}$  increases (that is, the larger the value of  $n$  is, the more the throughput efficiency of  $n$ -link SML-NARQ tends to descend more rapidly as  $\overline{P}_{be}$  increases). Obviously, in the case of bad channel conditions, the negative impact of block errors will seriously degrade the performance of the SML scheme.

- (4) There is a gradual decline in the throughput efficiency of SML-ARQ as  $\overline{P}_{be}$  increases. This indicates that the multilink retransmission scheme exploited in SML-ARQ can efficiently mitigate the negative impact of the frequent occurrence of block errors. For SML-ARQ, only in extremely bad wireless channel conditions (i.e., when  $\overline{P}_{be} \geq 0.78$ ), the potential throughput gain achievable by multilink retransmission will be offset by a high block error rate.

Figure 8 plots the normalized throughput efficiency of SML-ARQ as the payload length varies from 2300 Bytes, 2400 Bytes, 2500 Bytes, ..., to 3000 Bytes when setting  $\nu = 30$ , SNR = 12 dB, and 16-QAM. From this figure, we can see that:

- (1) The theoretical results closely match the simulation results. The average relative error between them is 0.9%. This manifests that our model is accurate.
- (2) For both 2-link SML-ARQ and 4-link SML-ARQ, the system throughput efficiency increases with increasing  $L_{payload}$ . The reason is that, in the contention process, SML-ARQ performs time domain

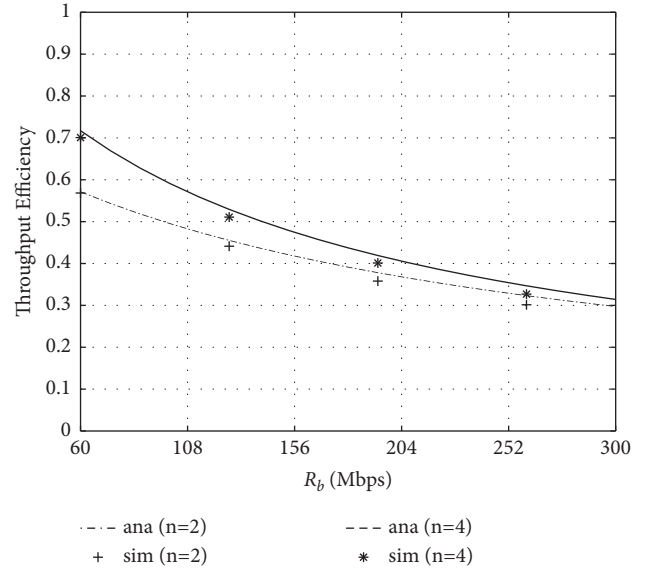

FIGURE 9: Throughput efficiency versus data rate.

channel contention following IEEE 802.11 DCF. Its contention process adopts binary exponential backoff (BEB), during which channel resources are wasted most of the time due to the channel being forced to remain idle in the case of all nodes performing random backoff. Therefore, the larger the payload, the smaller the fraction of time that the contention overhead occupies the channel, which in turn improves throughput efficiency.

- (3) The throughput efficiency in 4-link SML-ARQ is always higher than that in 2-link SML-ARQ. This is because (a) the number of available links in 4-link SML-ARQ is larger than that in 2-link SML-ARQ, thus improving the efficiency (that is, the time required to transmit a data packet is shorter); (b) ARQ mechanism effectively compensates for the drawback of failed transmissions caused by block error. Consequently, the 4-link SML-ARQ outperforms the 2-link SML-ARQ in terms of the system throughput.

Figure 9 plots the normalized throughput efficiency of SML-ARQ as the payload length varies from 60 Mbps, 80 Mbps, 100 Mbps, ..., to 300 Mbps when setting  $\nu = 30$ , SNR = 12 dB and 16-QAM. From this figure, we can see that:

- (1) For our protocol, the theoretical results closely match the corresponding simulation results (the average error between them is 1.6%), manifesting that our theoretical model is very accurate.
- (2) For both 2-link SML-ARQ and 4-link SML-ARQ, throughput efficiency decreases with the increase of  $R_b$ . The reason is that, with the increase of  $R_b$ , the PHY preamble is still transmitted at 6 Mbps; thereby, the fraction of time that the channel is used for transmitting payload gradually decreases.
- (3) The throughput efficiency in 4-link SML-ARQ is always higher than that in the 2-link SML-ARQ. This

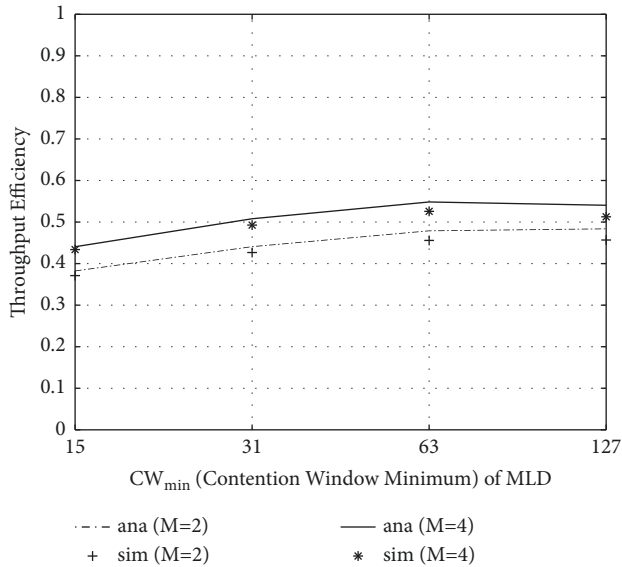

FIGURE 10: Throughput efficiency versus contention window minimum of MLD.

indicates that the 4-link SML-ARQ can achieve better performance than 2-link SML-ARQ.

Figure 10 plots the normalized throughput efficiency of SML-ARQ as the contention window minimum varies from 15, 31, . . . , to 127 when setting  $\nu = 30$ , SNR = 12 dB and 16-QAM. From this figure, we can see that:

- (1) For our protocol, the theoretical results well match the simulation results (the average error between them is 3.2%), manifesting that our theoretical model is accurate.
- (2) For both 2-link SML-ARQ and 4-link SML-ARQ, the throughput efficiency first gradually increases with the increase of  $CW_{\min}$  and then declines with the further increase of  $CW_{\min}$ . The reason is that a large  $CW_{\min}$  leads to a low collision probability and high contention overhead.
- (3) The throughput efficiency in 4-link SML-ARQ is always higher than that in the 2-link SML-ARQ, showing that the 4-link SML-ARQ can achieve better performance than 2-link SML-ARQ.

## 6. Conclusions

Multilink operation (MLO) is considered a key candidate technology in 802.11be, which allows devices to use multiple links to send and receive data simultaneously, thus helping improve throughput and reduce latency. However, as the channel environment deteriorates, the performance of MLO schemes will gradually degrade. To address this issue, in this paper, we first propose a multilink MAC protocol with a dynamic redundancy-based retransmission scheme consistent with the IEEE 802.11be. In the contention process, each MLD exploits multiple links to contend for channels simultaneously, thereby having a higher chance for winning channel contention compared to legacy single-link devices.

In the transmission process, a link packet will be partitioned into multiple blocks and then transmitted with multiple links. To ensure the reliability of data transmission, any failed blocks will be copied and retransmitted only one time using multiple links. Next, we develop a theoretical model to calculate system throughput. Finally, extensive simulations verify the accuracy of our theoretical model and the effectiveness of SML-ARQ. [5].

## Data Availability

The data underlying the results presented in the study are available within the article.

## Conflicts of Interest

The authors declare that are no potential conflicts of interest regarding the publication of this paper.

## Acknowledgments

This work is funded in part by the National Natural Science Foundation of China (file nos. 61872451 and 61872452) and in part by the Science and Technology Development Fund, Macau SAR (file nos. 0093/2022/A2 and 0076/2022/A2).

## References

- [1] E. Au, "IEEE 802.11be: extremely high throughput [standards]," *IEEE Vehicular Technology Magazine*, vol. 14, no. 3, pp. 138–140, 2019.
- [2] D. Lopez-Perez, A. Garcia-Rodriguez, L. Galati-Giordano, M. Kasslin, and K. Doppler, "IEEE 802.11be extremely high throughput: the next generation of wi-fi technology beyond 802.11ax," *IEEE Communications Magazine*, vol. 57, no. 9, pp. 113–119, 2019.
- [3] L. Cariou, *802.11 EHT Proposed PAR*, IEEE, 2019.
- [4] A. Garcia-Rodriguez, D. Lopez-Perez, L. Galati-Giordano, and G. Geraci, "IEEE 802.11be: wi-fi 7 strikes back," *IEEE Communications Magazine*, vol. 59, no. 4, pp. 102–108, 2021.
- [5] E. Au, *Specification Framework for TGbe*, Retrieved Mentor Ieee Org Httpsmentor Ieee Org80211dcn1911-19-1262-14-00bespecification-Framew, Tgbe Docx, 2020.
- [6] E. Khorov, I. Levitsky, and I. F. Akyildiz, "Current status and directions of IEEE 802.11be, the future wi-fi 7," *IEEE Access*, vol. 8, pp. 88664–88688, 2020.
- [7] A. López-Raventós and B. Bellalta, *Multi-link Operation in IEEE 802.11 Be WLANs*, IEEE Wirel. Commun, 2022.
- [8] *IEEE P802.11be/D1.0 Draft Standard for Information Technology— Telecommunications and Information Exchange between Systems Local and Metropolitan Area Networks— Specific Requirements.*, 2021.
- [9] T. Kim and T. Kim, "Performance analysis of synchronous multi-radio multi-link MAC protocols in IEEE 802.11be extremely high throughput WLANs," *Applied Sciences*, vol. 11, no. 1, p. 317, 2020.
- [10] D. Cavalcanti, S. Bush, M. Illouz, G. Kronauer, A. Regev, and G. Venkatesan, "Wireless TSN—Definitions, Use Cases & Standards Roadmap," *Avnu Alliance*, pp. 1–16, 2020.
- [11] G. Lacalle, I. Val, O. Seijo, M. Mendicute, D. Cavalcanti, and J. Perez-Ramirez, "Analysis of Latency and Reliability Improvement with Multi-Link Operation over 802.11," in *Proceedings of the 2021 IEEE 19th International Conference on*

- Industrial Informatics (INDIN)*, pp. 1–7, IEEE, Palma de Mallorca, Spain, July 2021.
- [12] R. P. F. Hoefel, “IEEE 802.11 be: throughput and reliability enhancements for next Generation Wi-Fi networks,” in *Proceedings of the 2020 IEEE 31st Annual International Symposium on Personal, Indoor and Mobile Radio Communications*, pp. 1–7, IEEE, London, UK, United Kingdom, August 2020.
- [13] A. Ahmed, A. Al-Dweik, Y. Iraqi, H. Mukhtar, M. Naeem, and E. Hossain, “Hybrid automatic repeat request (HARQ) in wireless communications systems and standards: a contemporary survey,” *IEEE Communications Surveys & Tutorials*, vol. 23, no. 4, pp. 2711–2752, 2021.
- [14] A. H. Sodhro, “A review on 802.11 MAC protocols industrial standards, architecture elements for providing QoS guarantee, supporting emergency traffic, and security: future directions,” *J. Ind. Inf. Integr.* vol. 4, 2021.
- [15] J.-S. Lin, K.-T. Feng, Y.-Z. Huang, and L.-C. Wang, “Novel design and analysis of aggregated ARQ protocols for IEEE 802.11 n networks,” *IEEE Transactions on Mobile Computing*, vol. 12, no. 3, pp. 556–570, 2012.
- [16] L. Zhu, B. Wu, and T. Ye, “An enhanced ARQ scheme for A-MPDU transmission under error-prone WLANs,” *IEEE Communications Letters*, vol. 23, no. 4, pp. 580–583, 2019.
- [17] C. Lu, B. Wu, L. Wang, Z. Wei, and Y. Tang, “A novel QoS-aware ARQ scheme for multi-user transmissions in IEEE802.11ax WLANs,” *Electronics*, vol. 9, no. 12, p. 2065, 2020.
- [18] C. Fang, Y. HanWangYanHeLongGuo, and Y. Guo, “IEEE 802.11be wi-fi 7: new challenges and opportunities,” *IEEE Communications Surveys & Tutorials*, vol. 22, no. 4, pp. 2136–2166, 2020.
- [19] W. Yun and J.-H. Yun, “Multi-link operation with enhanced synchronous channel access in IEEE 802.11be wireless LANs: coexistence issue and solutions,” *Sensors*, vol. 21, no. 23, p. 7974, 2021.
- [20] W. Yun and J.-H. Yun, “Multilink operation in IEEE 802.11be wireless LANs: backoff overflow problem and solutions,” *Sensors*, vol. 22, no. 9, p. 3501, 2022.
- [21] Y.-L. Tsai and Z. Tsai, “Performance analysis of two multi-channel fast retransmission schemes for delay-sensitive flows,” *IEEE Transactions on Vehicular Technology*, vol. 59, no. 7, pp. 3468–3479, 2010.
- [22] G. Tinnirello and I. Tinnirello, “Remarks on IEEE 802.11 DCF performance analysis,” *IEEE Communications Letters*, vol. 9, no. 8, pp. 765–767, 2005.
- [23] G. Bianchi, “Performance analysis of the IEEE 802.11 distributed coordination function,” *IEEE Journal on Selected Areas in Communications*, vol. 18, no. 3, pp. 535–547, 2000.
- [24] M. S. Patterh, T. S. Kamal, and B. S. Sohi, “BER performance of MQAM with L-branch MRC diversity reception over correlated Nakagami-m fading channels,” *Wireless Communications and Mobile Computing*, vol. 3, no. 3, pp. 397–406, 2003.
- [25] D. Yoon, K. Cho, and J. Lee, “Bit error probability of M-ary quadrature amplitude modulation,” vol. 5, pp. 2422–2427, in *Proceedings of the Vehicular Technology Conference Fall 2000. IEEE VTS Fall VTC2000. 52nd Vehicular Technology Conference (Cat. No. 00CH37152)*, vol. 5, pp. 2422–2427, IEEE, Boston, MA, USA, September 2000.
- [26] M. Nakagami, “The m-distribution-A general formula of intensity distribution of rapid fading,” *Statistical Methods in Radio Wave Propagation*, pp. 3–36, 1960.