

Review Article

Advanced Power Management and Control for Hybrid Electric Vehicles: A Survey

Jielin Jiang ^{1,2}, Qinting Jiang ¹, Jinhui Chen ¹, Xiaotong Zhou ¹, Shengkai Zhu ¹, and Tianyu Chen ¹

¹School of Computer and Software, Nanjing University of Information Science and Technology, Nanjing, China

²Jiangsu Collaborative Innovation Center of Atmospheric Environment and Equipment Technology (CICAET), Nanjing University of Information Science and Technology, Nanjing, China

Correspondence should be addressed to Qinting Jiang; q.jiang@nuist.edu.cn

Received 30 October 2020; Revised 13 December 2020; Accepted 24 December 2020; Published 7 January 2021

Academic Editor: Shaohua Wan

Copyright © 2021 Jielin Jiang et al. This is an open access article distributed under the Creative Commons Attribution License, which permits unrestricted use, distribution, and reproduction in any medium, provided the original work is properly cited.

With the trend of low emissions and sustainable development, the demand for hybrid electric vehicles (HEVs) has increased rapidly. By combining a conventional internal combustion engine with one or more electric motors powered by a battery, HEVs have the advantages over traditional vehicles in better fuel economy and lower tailpipe emissions. Nevertheless, the power management strategies (PMSs) for conventional vehicles which mainly focus on the efficiency of internal combustion engine are no longer applicable due to the complex internal structure of HEVs. Hence, a large number of novel strategies appropriate for HEVs have been surveyed, but most of the researches concentrate on discussing the classifications of PMSs and comparing their cons and pros. This paper presents a comprehensive review of power management strategies adopted in HEVs aiming at specific challenges for the first time. The categories of the existing PMSs are presented based on the different algorithms, followed by a brief study of each type including the analysis of its pros and cons. Afterwards, the implementation and optimization of power management strategies aiming at proposed challenges are introduced in detail with the description of their optimization objectives and optimized results. Finally, future directions and open issues of PMSs in HEVs are discussed.

1. Introduction

Currently, due to the dramatic expansion of the world population and economic boom in most countries, the ownership of private cars is rising sharply, which imposes a serious burden on energy distribution and environmental protection [1]. To be specific, conventional cars are mainly powered by burning fossil fuels (diesel and petrol), but these fuels are reserved limited and nonrenewable [2]. Additionally, poisonous gases (e.g., CO, CnHm, and NOx) emitted by vehicles not only generate air pollution and pose enormous threats to human health but also exacerbate the greenhouse effect which increases the likelihood of global climate disasters (e.g., hurricane, tsunami, and rise of sea level).

Hybrid electric vehicles (HEVs) are considered as one of the most innovative solutions to the above challenges. Compared with the single power structure of traditional fuel-based vehicles, the power supply system of HEV is composed

of several parts such as generator, internal combustion engine, and converter [3]. Such internal structure enriches the energy sources of HEV, enabling it to be driven by both electricity and heat, thus reducing the consumption of fossil fuels and emissions. Nevertheless, the power management strategies for conventional vehicles, which mainly focus on the efficiency of internal combustion engine, are no longer applicable due to the complex internal structure of HEV. New strategies are not only required to optimize the internal combustion engine but also to take the power of the battery, the flow, and the distribution of energy and collaboration of internal components (e.g., generator and internal combustion engine) into consideration [4]. Multiple management objectives greatly increase the complexity. The four main challenges in the HEV power management are as follows:

- (1) Real-time optimization. Compared with static optimization, real-time optimization can adjust the

power management strategy according to driving conditions, thus significantly improving the timeliness of the strategy [5]. Nevertheless, limited by existing technologies (e.g., GPS and BIMS), it is impossible to accurately predict, analyze, and assess future driving conditions which include road conditions, traffic flow, and surrounding environment. Consequently, real-time optimization adaptive to dynamic driving conditions is challenging [6]

- (2) Battery durability. Compared with the constant load conditions, the durability of fuel batteries tends to be significantly reduced under a dynamic loading condition [7]. Moreover, frequent charging and discharging process, switching voltages, and the flow of energy tend to accelerate battery aging
- (3) Computation load. The computation load generated by some power management strategies, such as dynamic programming (DP), is likely to increase substantially with the expansion of optimal objectives [8]. Additionally, since current vehicular networks have limited computation capabilities, they may have difficulty in processing such large scale data instantly. Hence, most of these strategies are merely limited to theoretical analysis instead of practical operation [9]
- (4) Multiple energy sources. Different from traditional fuel-based vehicles, HEV driven by multiple power sources has various energy flows and transitions internally. Hence, under diverse driving conditions, the cooperation of internal components (e.g., generator and internal combustion engine) and energy distribution tend to be more complicated [10]

A large number of power management strategies (PMSs) of HEV have been surveyed, but the current works are mainly focused on discussing the classifications of PMSs and comparing their cons and pros [11, 12]. No scholars have presented a comprehensive and thorough review of power management strategies aiming at specific challenges. To bridge this gap, a comprehensive and concrete survey of the recent research efforts on power management strategies in HEV in terms of above challenges is conducted in this paper, providing explicit research directions for later scholars [13].

The paper is organized as follows. Part II introduces the internal system framework of HEV, including power supply system, the generation of energy, and the cooperation of each part. Part III presents an overview of power management strategies of HEVs, providing their classifications and comparisons. After that, part IV reviews the implementation and optimization of power management strategies according to specific challenges raised above. Finally, part V discusses future trends and open issues of power management strategies in HEVs.

2. Power System Configuration

Due to the low dependency on fossil fuels [14], electric vehicles (EVs), especially hybrid electric vehicles, are recognized

as alternatives for conventional vehicles. Hybrid electric vehicles can be commonly classified into three types: series hybrid electric vehicles (SHEVs), parallel hybrid electric vehicles (PHEVs), and series parallel hybrid electric vehicles (SPHEVs) [15].

2.1. Series Hybrid Electric Vehicles. The power system of a series hybrid electric vehicle consists of several batteries, a decoupled-from-wheel engine, an electric generator, and a motor [16]. The structure and the energy flow are shown in Figure 1. The main driving power for the wheels is directly provided by the battery pack rather than the engine. Additionally, the engines of SHEVs are utilized to drive the electric generators to charge the battery pack. The power released by the battery pack will then drive the motor to provide necessary energy and torque for the wheels [17].

During the energy conversion process, the energy forms are totally transformed three times, more than that of conventional vehicles. Due to such energy conversion mechanism, the engine is able to work smoothly. Thus, the redundant energy consumption caused by the external environment can be avoided to some extent. Nevertheless, if a SHEV runs at a high speed, this conversion process will reduce the energy efficiency, making it even lower than that of conventional vehicles. Based on the advantages and disadvantages analyzed above, this kind of HEVs can adapt to different situations when running at a low speed. For instance, the SHEVs technology tends to be utilized in the application of city-buses where frequent starts together with a low speed are demanded.

2.2. Parallel Hybrid Electric Vehicles. Different from SHEVs, PHEVs are driven by electric power and traditional heat energy simultaneously. Namely, that the energy sources of a PHEV are both the battery pack and the engine. The electricity stored in the battery pack is delivered to the motor. Meanwhile, the engine distributes its energy to the wheels and the electric generator to charge the batteries (Figure 2). Then, the power provided by the batteries and the engine works together to drive the wheels [18].

Owing to the design of multiply energy sources, the energy efficiency of PHEVs is higher than that of SHEVs. Nevertheless, the energy efficiency will be reduced if the state of charge (SOC) of the battery pack is low. Additionally, a battery pack with perfect SOC helps PHEVs work under a high-efficiency state. Hence, maintaining the SOC of the battery pack is another critical issue [19].

2.3. Series-Parallel Hybrid Electric Vehicles. The power system of a SPHEV is usually composed of an engine, two motors, two generators, and a battery pack. Such system lets the SPHEVs obtain the advantages of both SHEVs and PHEVs. SPHEVs are capable of working in different modes under various situations. Thus, SHEVs are more flexible in mode operation and more environmentally friendly [20]. The power supply of SPHEVs can be mechanical, electrical, or the both. For instance, when the battery pack is able to meet the energy requirements, the pure electric mode will be chosen; when the state of charge of the battery pack is

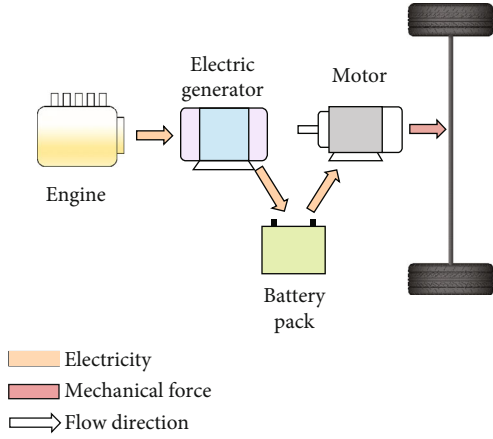

FIGURE 1: The power system diagram of SHEVs.

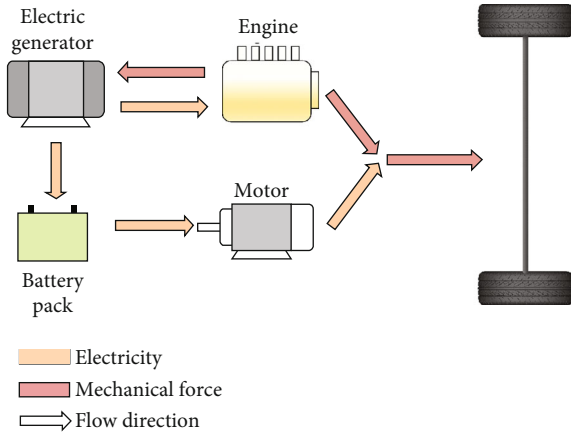

FIGURE 2: The power system diagram of PHEVs.

low or more power is needed, the engine will be turned on to satisfy the demand. However, flexible mode operation tends to cause the challenges of mode chosen and energy arrangement. Additionally, SPHEVs have some disadvantages both in production and economy. Firstly, the structure is of high cost, which may result in the difficulty of mass production. Hence, the widespread adoption will be a challenge. Moreover, the complexity of the structure leads to a technology monopoly between different automobile manufacturers, so the energy consumptions of vehicles from different companies may vary greatly.

The main structure of SPHEVs is shown in Figure 3. The transducer can provide the supply voltage needed by the motor owing to an internal inverter. Motors can be used as electric generators if necessary, so it is called as motor/generator (MG). The planetary gear train is a special structure which works as a power split device [21]. The rotation axis of the planetary gear carrier is connected to the engine and makes the planetary gears work together with the sun gear. The rotation axis of the sun gear is connected to MG1. The sun gear generates electric energy with the assistance of the engine. Meanwhile, the rotation axis of the planetary gear carrier is linked to MG2. The planetary gear provides power to the wheels.

As mentioned above, the complex structure may cause a series of problems. Firstly, the changeable driving condition requires that the driving mode should be chosen wisely by the control system. Moreover, the cooperation between electricity and conventional energy may not be smoothly enough, which often leads to low energy efficiency and more emissions.

3. Overview of HEV Power Management Strategies

3.1. Dynamic Programming. Dynamic programming (DP) is an optimization method commonly used in multistage decision-making process [22]. The optimization of energy consumption and emissions in HEV can just be regarded as such process in the discrete-time format [23]. Since DP is capable of finding the global optimum accurately, it is frequently applied in the power management of HEV to find the control solution. The state transition equation in HEV is showed in (1)

$$x(k+1) = f(x(k), u(k)), \quad (1)$$

where $u(k)$ is the vector of control variables, such as the desired output torque from the engine and the gear shift command to the transmission, and $x(k)$ is the state vector of the system. The optimization goal of DP is to find the control input $u(k)$ to minimize a cost function which consists of energy consumption and emissions. The cost function can be written as

$$J = \sum_{k=0}^{N-1} L(x(k), U(k)), \quad (2)$$

where N is the duration of the driving cycle, and L is the instantaneous cost including energy consumption and emissions which should be minimize. By leveraging the property that DP is based on Bellman's principle of optimality, we can easily obtain the optimal strategy. Specifically, we break down the original problem into several subproblems. The subproblem which involves only the last stage is solved primarily. Then, the subproblems involving the last two stages, the last three stages are gradually considered. The basic process of DP is presented in (3) and (4).

Step $N-1$:

$$J_{N-1}^*(x(N-1)) = \min_{u(N-1)} [L(x(N-1), u(N-1))], \quad (3)$$

Step k , for $0 \leq k < N-1$

$$J_k^*(x(k)) = \min_{u(k)} [L(x(k), u(k)) + J_{k+1}^*(x(k+1))]. \quad (4)$$

During the optimization, it is necessary to take some inequality constraints into consideration to ensure safe and smooth operation of engine, motor, and battery such as the engine torque, the motor torque, the battery state of charge, and the engine speed [24].

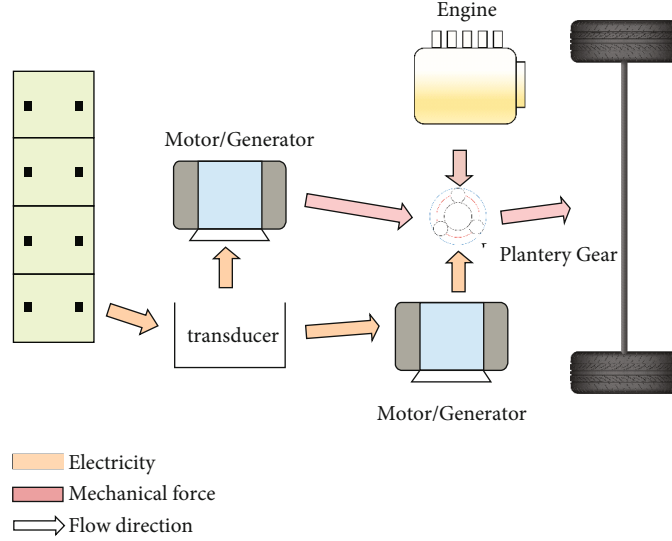

FIGURE 3: The power system diagram of SPHEVs.

Generally, DP is difficult to be directly used for this optimization process because of the high number of states in the model, i.e., curse of dimensionality [25, 26]. Therefore, the feasible methods based on DP always have been improved.

3.2. Genetic Algorithm. Genetic algorithm (GA) is a method which searches for the optimal solution by simulating the natural evolution process [27]. HEV is able to reduce energy consumption and emissions by leveraging the method of GA [28, 29].

Different parameter settings are regarded as different individuals in GA; then, the gene of each individual is coded by its own setting [30]. For example, an individual's genes can be expressed in binary numbers, such as genes = 00110100, which corresponds to a value within certain range of parameters.

The value of the fitness function is related to energy consumption and emissions which determined by genes, i.e., individuals with low energy consumption, and emissions genes are more likely to survive [31].

The processes of GA include initialization, selection, crossover, and mutation. Firstly, the genes of individual genes are coded randomly, i.e., individual genes are evenly distributed. Secondly, every individual is evaluated by its value of fitness function which determines its probability of survival. Third, the new individual is elected by its survival probability which can calculate by

$$p[i] = \frac{f_i}{\sum_{i=1}^n f_i}, \quad (5)$$

where f_i is the value of i^{th} individual of fitness function, $p[i]$ represents the probability that the i^{th} individual is selected, and n is the number of individuals. Finally, a new generation will be formed after necessary crossover and mutation. The iteration will keep going until the best individual fulfills the

termination criteria, i.e., the energy consumption and emissions meet the requirements.

GA has a certain dependence on the selection of the initial population and can be improved by combining some heuristic algorithms. Nevertheless, the feedback information may fail to be used in time. Thus, the search speed of the algorithm is relatively slow, and training time is required to increase to obtain a more accurate solution [32].

3.3. Particle Swarm Optimization. Particle swarm optimization (PSO) is a random search algorithm based on group collaboration. PSO has fast convergence speed and does not need the strict condition that the optimization function has differentiability. Hence, PSO is usually leveraged to optimize the control strategy in different situations [33, 34].

PSO algorithm first initializes a group of random particles, and then the particles follow the current optimal particles in the solution space to find the optimal solution through iteration. The iteration formula is given in (6)

$$\begin{aligned} v_{ij}(t+1) &= wv_{ij}(t) + c_1r_1[p_{ij} - x_{ij}(t)] + c_2r_2[p_{gj} - x_{ij}(t)], x_{ij}(t+1) \\ &= x_{ij}(t) + v_{ij}(t+1), j = 1, 2, \dots, d, \end{aligned} \quad (6)$$

where w is the inertia weight factor, c_1 and c_2 are learning factors, r_1 and r_2 are random numbers.

Similar to GA, PSO also regards variables to be optimized as particles and keeps getting closer to the needed result, but the information sharing mechanisms of the two methods are different [35]. The information flow is one-way in PSO, and the entire search update process follows the current optimal solution. Hence, all particles converge to the optimal solution at a fast speed. However, PSO is also more likely to fall into a local optimum situation [36].

3.4. Fuzzy Control. Fuzzy control has been introduced to the power management in HEVs. The aims of fuzzy control are

to achieve high efficient work and meet certain requirements by adjusting the current and the voltage. Meanwhile, it tries to avoid affecting the performance and efficiency of the entire system [37]. Compared with rule control, fuzzy control can output ratio according to different operating conditions. Additionally, fuzzy rules are easy to be adjusted and is robust to model errors and inaccurate measurements [38, 39].

In fuzzy control, the controller performs the basic steps of fuzzy logic. Primarily, the inputs are fuzzified into membership functions; then, the fuzzy outputs are computed by expertise-based rules. Ultimately, the outputs are fuzzified to proportional control signals [40, 41].

Although fuzzy control can optimize power management or emissions to a certain extent, it relies heavily on rules based on experience and fails to adjust according to the actual situation [22].

3.5. Equivalent Cost Minimization Strategy. Equivalent cost minimization strategy (ECMS) is a method frequently adopted in the PMSs of HEVs. By leveraging equivalent factors and predicting future costs to compensate the energy, ECMS convert the on-board electric energy depletion to an equivalent fuel consumption [42, 43].

The results revealed that the ability of ECMS can obtain a near optimal solution compared with DP at lower computational requirements. If powertrain components have constant efficiencies (mean value), then the cost to be minimized will be defined as (7)

$$C_{\text{tot}} = C_{\text{ICE}}(k(t), T_{\text{th}}(t)) + C_{\text{eq}}(k(t), T_{\text{th}}(t)) \quad (7)$$

where C_{ICE} is the real engine fuel consumption, and C_{eq} is electric motor equivalent fuel consumption. The design variables are the gear number $k(t)$, and the torque driver demands $T_{\text{th}}(t)$. The equivalence of electric energy is calculated by different charge or discharge processes of the battery

$$C_{\text{eq}}(k(t), T_{\text{th}}(t)) = \begin{cases} \frac{SFC_{\text{rech}} \cdot P_e(\omega_e, T_e)}{\bar{\eta}_e \bar{\eta}_{\text{batt}} \cdot 3.6 \cdot 10^6} \forall T_e < 0 \\ \frac{SFC_{\text{dis}} \cdot P_e(\omega_e, T_e) \bar{\eta}_e \bar{\eta}_{\text{batt}}}{3.6 \cdot 10^6} \forall T_e \geq 0 \end{cases} \quad (8)$$

where SFC_{rech} and SFC_{dis} are the recharge and discharge mean specific fuel consumption, $\bar{\eta}_e$ and $\bar{\eta}_{\text{batt}}$ are the mean efficiency of electric motor and battery, and P_e is the motor power at torque T_e . The main challenge of ECMS is to consider the efficiency of each component and the dynamics of the power supply to estimate these equivalent factors.

3.6. Reinforcement Learning. Reinforcement learning (RL) is developed from theories of animal learning and parameter disturbance adaptive control. Its basic principles are as follows: if a certain behavior strategy of the agent leads to positive rewards (reinforcing signals) in the environment, then the tendency of the agent to produce such behavior strategy in the future will be strengthened. The goal of the agent is

to find the optimal strategy in each discrete state to maximize the expected sum of discount rewards [44, 45].

The transition probability matrix can be expressed by

$$\begin{cases} P_{i,j} = \frac{M_{i,j}}{M_i} \\ M_i = \sum_{j=1}^N M_{i,j} \end{cases} \quad (9)$$

The optimal value of states is defined as the expected sum of discount rewards which can be represented as (10)

$$V^*(s) = \min_{\pi} E \left(\sum_{t=t_0}^{t=t_f} \gamma^t r_t \right), \quad (10)$$

where π is a policy, and $\gamma \in [0, 1]$ is the discount factor.

The low sampling efficiency and requirements of huge learning time restrict the usage of RL. Therefore, RL needs to be leveraged under the right circumstances.

4. The Implementation and Optimization of PMSS

Although the HEVs have made great progress in improving fuel economy, reducing emissions, and achieving better vehicle performance, they still face significant challenges in power management. The challenges include real-time optimization, battery durability, computational load, and the power allocation among multienergy sources. To this endeavor, with the continuously advancing investigations, the novel power management strategies have been proposed. In this section, the advanced power management strategies aiming to address these challenges are discussed.

4.1. The Real-Time Optimization. In the real-time optimization, the optimal solution is often obtained based on the forecast of future conditions. It indicates that the future driving conditions, such as traffic conditions, road grade, and surrounding environment, are prerequisites for the real-time optimization. Accordingly, the methods utilized for the prediction of the future information are essential for the optimization of the power management strategy in real time.

Since the Markov chain is able to predict the power demand and vehicle velocity under stochastic circumstances, the strategies based on the Markov chain have been proposed. Zeng and Wang [19] proposed a stochastic model predictive strategy for the PHEV model under the hilly driving environment. The strategy modeled the grade, the speed change, and the stop and turning information as a Markov chain and applied a stochastic dynamic programming (SDP) strategy to maintain the battery SOC. Zou et al. [46] presented a three-dimensional Markov chain driving model for the tracked vehicles, where a nearest-neighborhood method was utilized to update an online transition probability matrix, and a SDP method for the tracked vehicles validated the reliability of the nearest-neighborhood approach. Additionally, Li et al. [47] designed a novel driving-

behavior-aware model predictive control method. The K -means was utilized to classify driving behaviors, and the Markov chain was employed to obtain driver models under different driving behaviors.

Due to the strong abilities in predicting and modeling, the artificial intelligence has been employed to forecast the driving cycles. Chen et al. [48] proposed a particle swarm optimization algorithm to optimize a rule-based power management strategy under a certain driving cycle. Meanwhile, a driving condition recognition algorithm was employed to identify real-time driving conditions by fuzzy logic. To address the problem that the thresholds are sensitive to the different driving cycles, a dynamic optimal parameter algorithm was established. Sun et al. [49] designed a velocity predictor based on a neural network to predict the short-term future driving behaviors. The velocity predictor was combined with adaptive-ECMS to provide temporary driving information for real-time equivalence factor adaptation. Liu et al. [50] presented a reinforcement learning-based adaptive energy management for a hybrid electric, where fuel consumption was minimized over different driving schedules to guarantee power demand. Table 1 lists the main strategies designed for the real-time optimization.

4.2. The Battery Durability. The HEV system requires high energy capacities for long driving distances and high power capacities for accelerating, climbing, or braking. These requirements (high energy capacities and high power capacities) keep the battery in frequent discharge-charge condition. Nevertheless, the battery durability is impaired by the high discharge-charge rates, leading to a reduction in fuel economy. Hence, a proper power management for HEV is required to fulfill the durability of the battery.

To deal with the battery durability, a system-level design is essential. Capasso et al. [51] developed an optimal control strategy, which exploits the off-line solution of an isoperimetric problem and dynamically optimizes the battery durability via reducing peak current. The results showed the effectiveness of the strategy in reducing the high charging/-discharging current peaks to increase the battery durability. In addition, Zhang et al. [52] proposed a hysteresis control strategy for HEV with three fuel cell stacks, where each fuel cell stack works at a fixed operating point, and its active time is shortened by on-off switching control. Combined with the power capability and SOC states, Wang et al. [53] designed a finite state machine-based management strategy and presented an optimal oxygen excess ratio control to maximize the net power of fuel cell. The simulated results indicated that the method guarantees the required power during the driving cycles. Additionally, by taking the battery durability into consideration, the power management strategies can obtain the near-optimal solution. Zhang et al. [54] proposed an optimal power management strategy based on the DP algorithm and verified by the different battery SOC and battery state-of-health (SOH) conditions, which guarantees a better strategy control performance. To optimize the control of the fuel cell system, Robin et al. [55] designed a mechanistic catalyst dissolution model to predict the lifetime of fuel cell and utilized a model inversion to forecast the performance loss. The

mechanistic catalyst dissolution model successfully passed the battery durability test in dynamic operation conditions. The effect and strategies that have been put forward in developing the battery durability are shown in Table 2.

4.3. Computational Load. Due to the curse of dimensions, the data required to support a reliable result tends to multiply exponentially with the increase in variables. A mass of data leads to a high computation load or even an inability to calculate. Consequently, some power management strategies (e.g., dynamic programming) fail to be applied for the power management of HEV without the optimization for computational complexity in practice.

Larsson et al. [56] put forward a method based on local approximation of the gridded cost-to-go and utilized local approximations at the appropriate control signal to reduce the quantized interpolation. Combined with the particle swarm optimization (PSO), Yang et al. [57] proposed a rapid-DP optimization strategy to select the optimal control state of the motor and further improved fuel economy of the vehicle.

With the proposal of level-set DP in [58], the computing time of DP was decreased by 300 times. Nevertheless, more challenges, e.g., the Markov and standardization problems, were raised. To deal with these problems, Zhou et al. [59] proposed a unified solution method, where the Markov characteristics of DP were utilized to construct a unified equation of state. A massive amount of data in the computing was reduced by filters based on state variables and control variables. This method was faster than the conventional DP, reducing computation time by 96.48% and 23.44% compared with basic DP and level-set DP.

Due to the low computational complexity of neural network, Li et al. [60] presented a power management strategy based on reinforcement learning without worrying curse of dimensionality in complex environments, where stochastic gradient descent and experience replay were adopted to guarantee the accuracy and stability of the method.

The strategies to address the computational load discussed are listed in Table 3.

4.4. The Power Allocation of Multiple Energy Sources. Compared with EVs, PHEVs have longer driving ranges. On the one hand, the engine allows the vehicle to work when the battery SOC is at a low state, which is similar to the situation of conventional vehicles. On the other hand, the engine will be turned off, and the vehicle will be driven by the electric power system when the speed or the power demand is low. Therefore, the driving performance depends on the power allocation among multienergy sources.

Many valuable works related to power management for HEVs with multienergy sources, where intelligent strategies (e.g., fuzzy logic, dynamic programming, and particle swarm optimization [48]) are utilized to optimize energy allocation among multiple sources, have been widely conducted. Nevertheless, most of the works investigate power management strategies for the HEVs powered by the battery and engine or the battery and ultracapacitor, and few of them aim at

TABLE 1: Main strategies proposed to deal with the real-time optimization.

Reference	Solution	Highlights
[19]	Markov chains and stochastic dynamic programming	(1) Model the road grade as a Markov chain (2) Maintain the SOC within its boundary
[46]	Markov chains and nearest-neighborhood method	(1) Present a three-dimensional Markov chain driver model (2) Update transition probability matrix online
[47]	Markov chains	(1) Classify eight typical driving behaviors (2) Establish driver models under different driving behaviors
[48]	Particle swarm optimization and fuzzy logic	(1) Pay attention to uncertain driving condition (2) Avoid thresholds sensitive to driving cycles
[49]	Neural network	(1) Design a velocity predictor (2) Real-time adaptation
[50]	Reinforcement learning	(1) Present a control-oriented dynamic model (2) Method adaptability under different driving conditions

TABLE 2: Main strategies proposed to deal with the battery durability.

Reference	Solution	Highlights
[51]	Isoperimetric optimization	(1) Dynamically optimize battery durability (2) Reduce high discharge-charge current peaks
[52]	Optimal control	(1) Propose a hysteresis power management and control strategy (2) Provide a novel configuration
[53]	Finite state machine	(1) Consider power capability and SOC (2) Maximize the net power
[54]	Dynamic programming	(1) Consider battery durability (2) Verify strategies under SOC and SOH condition
[55]	Lifetime prediction	(1) Design a mechanistic catalyst dissolution model (2) Forecast the performance loss

TABLE 3: Main strategies proposed to deal with deal with the computational load.

Reference	Solution	Highlights
[56]	Local approximation	(1) Reduce interpolation (2) Reduce computing time by two orders of magnitude
[57]	Rapid-DP and particle swarm optimization	(1) Propose a joint optimization (2) Improve fuel economy
[58]	Level-set function	(1) Decrease computing time of DP by 300 times
[59]	A unified DP model	(1) Solve the Markov problem in DP (2) Reduce computation data
[60]	Reinforcement learning	(1) Avoid the curse of dimensionality (2) Complex environment stability

the power management strategies of vehicles with more than two sources.

In the hybrid energy storage system (HESS), a battery and an ultracapacitor are combined to reduce the charge rate of the battery. To deal with the energy allocation problem among the HESS and engine-generator, Zhang and Xiong [61] proposed a hierarchical control strategy, where a fuzzy logic controller was employed for classifying the driving patterns, and the DP method was utilized to develop control strategies for different driving blocks. However, in [61], the HESS is viewed as a single source, and the power of the battery and ultracapacitor was determined by the deterministic

required power. Thus, an integrated power management strategy where the battery and the ultracapacitor were regarded as difference power sources [62] was designed, including HESS and an assistance power unit (APU). Utilizing a model predictive control (MOC) controller, the power allocation between battery and ultracapacitor could be realized, while the output power of HESS and APU is allocated by the rule-based strategy. To obtain the real-time power allocation between the battery and the ultracapacitor for the HESS, Xiong et al. [63] presented a reinforcement learning-based energy management, which could learn current driving power information and update the strategy in time.

TABLE 4: Main strategies proposed to deal with deal with the multiple energy sources.

Reference	Solution	Highlights
[61]	Driving pattern recognition and dynamic programming	(1) Propose a hierarchical control strategy for HESS (2) Classify different driving patterns
[62]	Model predictive control and dynamic programming	(1) Design an assistance power unit (2) Pay attention to the power allocation between battery and ultracapacitor (3) Present an MPC controller
[63]	Reinforcement learn	(1) Real-time power allocation strategy
[64]	Fuzzy logic control genetic algorithm	(1) Propose a novel method for FCS
[43]	Equivalent consumption minimization strategy	(1) Pay attention to the PEMFC (2) Improve overall efficiency

Ahmadi et al. [64] proposed a novel power allocation method for the fuel-cell vehicle powered by the fuel-cell system (FCS), battery, and ultracapacitor, and implemented an intelligent control technique based on fuzzy logic control, which determines the required power for FCS and ultracapacitor. Additionally, since the proton exchange membrane fuel cell (PEMFC) plays an important role in developing the fuel-cell vehicle, Li et al. [43] designed a system, where PEMFC, two batteries, and two supercapacitors were combined to avoid the rapid changes of power demand, and ECMS was utilized to achieve better energy efficiency of the overall system.

The strategies are summarized and shown in Table 4.

5. Open Issues and Challenges

This section puts forwards some remaining challenges of power management strategies in HEVs that should be taken into account, and the open issues and future trends will also be discussed.

5.1. System Stability. The power system in HEVs consists of multienergy sources (e.g., motor, engine, and battery), power switching unit, and converters. These components tend to be affected by the changes in parameters such as temperature, discharge-charge rate, and load variation [10]. Consequently, the disturbance from the parameters leads to changing power demands, battery overload, and low power quality, which eventually results in the instability of the vehicle power system [65]. To deal with the challenge for system stability, the design of the power management strategies is ought to take the terminal cost and stability constraints into account to guarantee the stable system operation [66, 67].

5.2. System Robustness. The robustness of the power management strategies refers to the ability of the control system to maintain the model stability and resist system noises and disturbances [68]. Nevertheless, most of the power management and control strategies for the HEVs are simulated in the specific scenarios, ignoring the uncertainties that may occur in a real scenario. Such static power management strategies are likely to cause a poor vehicle performance.

On the one hand, some power management strategies, such as Markov chains, are based on the collected data.

Therefore, if the real driving conditions differ from the collected data of the driving cycles, the algorithms fail to the optimization [69]. On the other hand, the components in the system configuration, such as generators, batteries, and capacitors, always age and wear out during the operation, resulting in uncertainties of the configuration and parameter [70, 71].

Accordingly, based on the power management strategy for HEVs, the robust control strategy adopted to the real scenario requires investigating.

5.3. Edge Computing. Currently, technologies related to edge computing are being studied extensively. Different from the centralized computing model of cloud computing, mobile users look for nearby available devices and base stations to offload the current computation tasks in an edge computing scenario [72]. Data transfer overhead and latency are greatly reduced as the edge nodes are closer to the user [73].

Due to the increasing requirements of the low latency and computing for power management strategies in HEV, it is necessary to move the computational nodes from the cloud data centers to the edge nodes [74, 75]. Additionally, computing offloads on edge devices enhance the responsiveness of the service while significantly reducing the energy loss caused by data transfer. Meanwhile, the distributed computing nodes have the potential to enable the robustness of the power management strategies to guarantee the vehicle safety, real-time optimization, and fuel economy [76].

5.4. Smart Grid. With the rapid expansion of strategic emerging industries like hybrid electric vehicles, great importance has been attached to an electric automation level in enhancing overall efficiency and improving electricity supply reliability [77].

Smart grid is a modern power grid featured as being automatic, interactive, and IT-based. It is composed of different types of generation sources along with introduction of information and communication technologies (ICT). Supported by the intelligent control and IT platform, smart grid involves six segments including power generation, transformation, transmission, distribution, dispatching, and consumption. In the scenario of smart grid, the charging efficiency of hybrid electric vehicles will be significantly improved, followed by the reduced charging cost [78].

5.5. Battery Aging. Battery aging is a common issue in many types of batteries. During the charging and discharging process, chemical reactions take place inside the battery constantly which corrodes the cathode of the battery until the cathode completely deteriorates. Batteries should be replaced regularly if the aging issue is serious. Thus, battery exerts an important influence on the overall cost of HEVs. Although many studies have been conducted on power management strategies of HEV, only a few of them take this issue into consideration [79].

One promising solution is to combine a supercapacitor with the battery. Compared to supercapacitor, battery has better energy density but poor power density to release energy sharply. Moreover, the cycling life of battery is much shorter. On the other hand, although supercapacitor has lower energy density, it generally has much higher power density. The combination of the both can play a complementary role.

6. Conclusion

The characteristics of low energy consumption and limited emissions of HEV make it a promising industry. Substituting HVEs for conventional fuel-based vehicles is expected to alleviate the current energy shortage and serious environmental pollution. The goal of this paper is to comprehensively study the power management strategies for HEVs aiming at specific challenges. The main challenges in power management strategies for HEVs are listed at the beginning. After a brief introduction on internal dynamic structures of HEV and an overview of existing power management strategies, the comparisons and experimental results of each method are also presented. Eventually, several open issues and future trends of HEVs are discussed.

Data Availability

No data were used to support this study.

Conflicts of Interest

The authors declare no conflicts of interest.

Acknowledgments

This work was supported in part by the National Natural Science Foundation of China under Grant no. 61601235, in part by the Natural Science Foundation of Jiangsu Province of China under Grant no. BK20160972. Meanwhile, the authors extend their appreciation to the Deanship of Scientific Research at King Saud University for funding this work through research group no. RG-1441-331.

References

- [1] R. Dominguez, J. Solano, and A. Jacome, "Sizing of fuel cell - ultracapacitors hybrid electric vehicles based on the energy management strategy," in *2018 IEEE Vehicle Power and Propulsion Conference (VPPC)*, pp. 1–5, Chicago, IL, 2018.
- [2] A. Rezaei, J. B. Burl, M. Rezaei, and B. Zhou, "Catch energy saving opportunity in charge-depletion mode, a real-time controller for plug-in hybrid electric vehicles," *IEEE Transactions on Vehicular Technology*, vol. 67, no. 11, pp. 11234–11237, 2018.
- [3] J. Guan and B. Chen, "Adaptive power management strategy based on equivalent fuel consumption minimization strategy for a mild hybrid electric vehicle," in *2019 IEEE Vehicle Power and Propulsion Conference (VPPC)*, pp. 1–4, Hanoi, Vietnam, 2019.
- [4] S. S. George and M. O. Badawy, "A modular multi-level converter for energy management of hybrid storage system in electric vehicles," in *2018 IEEE Transportation Electrification Conference and Expo (ITEC)*, pp. 336–341, Long Beach, CA, 2018.
- [5] R. Ghaderi, M. Kandidayeni, M. Soleymani, and L. Boulon, "Investigation of the battery degradation impact on the energy management of a fuel cell hybrid electric vehicle," in *2019 IEEE Vehicle Power and Propulsion Conference (VPPC)*, pp. 1–6, Hanoi, Vietnam, 2019.
- [6] D. He, Y. Zou, J. Wu, X. Zhang, Z. Zhang, and R. Wang, "Deep Q-learning based energy management strategy for a series hybrid electric tracked vehicle and its adaptability validation," in *2019 IEEE Transportation Electrification Conference and Expo (ITEC)*, pp. 1–6, Detroit, MI, USA, 2019.
- [7] J. Guo, H. He, and C. Sun, "ARIMA-based road gradient and vehicle velocity prediction for hybrid electric vehicle energy management," *IEEE Transactions on Vehicular Technology*, vol. 68, no. 6, pp. 5309–5320, 2019.
- [8] J. Oncken and B. Chen, "Real-time model predictive powertrain control for a connected plug-in hybrid electric vehicle," *IEEE Transactions on Vehicular Technology*, vol. 69, no. 8, pp. 8420–8432, 2020.
- [9] J. Wu, J. Ruan, N. Zhang, and P. D. Walker, "An optimized real-time energy management strategy for the power-split hybrid electric vehicles," *IEEE Transactions on Control Systems Technology*, vol. 27, no. 3, pp. 1194–1202, 2019.
- [10] S. Zhou, Z. Chen, D. Huang, and T. Lin, "Model prediction and rule based energy management strategy for a plug-in hybrid electric vehicle with hybrid energy storage system," *IEEE Transactions on Power Electronics*, 2020.
- [11] H. H. Nguyen, J. Kim, G. Hwang, S. Lee, and M. Kim, "Research on novel concept of hybrid electric vehicle using removable engine-generator," in *2019 IEEE Vehicle Power and Propulsion Conference (VPPC)*, pp. 1–5, Hanoi, Vietnam, 2019.
- [12] Q. Sun, J. Wu, C. Gan, J. Si, J. Guo, and Y. Hu, "Cascaded multiport converter for SRM-based hybrid electrical vehicle applications," *IEEE Transactions on Power Electronics*, vol. 34, no. 12, pp. 11940–11951, 2019.
- [13] L. Zhang, X. Hu, Z. Wang, F. Sun, J. Deng, and D. G. Dorrell, "Multi-objective optimal sizing of hybrid energy storage system for electric vehicles," *IEEE Transactions on Vehicular Technology*, vol. 67, no. 2, pp. 1027–1035, 2018.
- [14] P. G. Anselma, Y. Huo, J. Roeleveld, G. Belingardi, and A. Emadi, "Integration of on-line control in optimal design of multimode power-split hybrid electric vehicle powertrains," *IEEE Transactions on Vehicular Technology*, vol. 68, no. 4, pp. 3436–3445, 2019.
- [15] A. Macias Fernandez, M. Kandidayeni, L. Boulon, and H. Chaoui, "An adaptive state machine based energy management strategy for a multi-stack fuel cell hybrid electric vehicle,"

- IEEE Transactions on Vehicular Technology*, vol. 69, no. 1, pp. 220–234, 2020.
- [16] J. Gissing, P. Themann, S. Baltzer, T. Lichius, and L. Eckstein, “Optimal control of series plug-in hybrid electric vehicles considering the cabin heat demand,” *IEEE Transactions on Control Systems and Technology*, vol. 24, no. 3, pp. 1126–1133, 2016.
- [17] Y. Li, H. He, J. Peng, and H. Wang, “Deep reinforcement learning-based energy management for a series hybrid electric vehicle enabled by history cumulative trip information,” *IEEE Transactions on Vehicular Technology*, vol. 68, no. 8, pp. 7416–7430, 2019.
- [18] L. Li, C. Yang, Y. Zhang, L. Zhang, and J. Song, “Correctional DP-based energy management strategy of plug-in hybrid electric bus for city-bus route,” *IEEE Transactions on Vehicular Technology*, vol. 64, no. 7, pp. 2792–2803, 2015.
- [19] X. Zeng and J. Wang, “A parallel hybrid electric vehicle energy management strategy using stochastic model predictive control with road grade preview,” *IEEE Transactions on Control Systems Technology*, vol. 23, no. 6, pp. 2416–2423, 2015.
- [20] H. Zhang, Y. Zhang, and C. Yin, “Hardware-in-the-loop simulation of robust mode transition control for a series-parallel hybrid electric vehicle,” *IEEE Transactions on Vehicular Technology*, vol. 65, no. 3, pp. 1059–1069, 2016.
- [21] A. Gayebloo and A. Randan, “Superiority of dual-mechanical-port-machine-based structure for series-parallel hybrid electric vehicle applications,” *IEEE Transactions on Vehicular Technology*, vol. 65, no. 2, pp. 589–602, 2016.
- [22] M. Passalacqua, D. Lanzarotto, M. Repetto, L. Vaccaro, A. Bonfiglio, and M. Marchesoni, “Fuel economy and EMS for a series hybrid vehicle based on supercapacitor storage,” *IEEE Transactions on Power Electronics*, vol. 34, no. 10, pp. 9966–9977, 2019.
- [23] D. S. Mendoza, P. Acevedo, J. S. Jaimes, and J. Solano, “Energy management of a dual-mode locomotive based on the energy sources characteristics,” in *2019 IEEE Vehicle Power and Propulsion Conference (VPPC)*, pp. 1–4, Hanoi, Vietnam, 2019.
- [24] Z. H. C. Daud, Z. Asus, S. A. A. Bakar, N. A. Husain, I. I. Mazali, and D. Chrenko, “Thermal characteristics of a lithium-ion battery used in a hybrid electric vehicle under various driving cycles,” *IET Electrical Systems in Transportation*, vol. 10, no. 3, pp. 243–248, 2020.
- [25] A. Rezaei, J. B. Burl, B. Zhou, and M. Rezaei, “A new real-time optimal energy management strategy for parallel hybrid electric vehicles,” *IEEE Transactions on Control Systems Technology*, vol. 27, no. 2, pp. 830–837, 2019.
- [26] C. Zhu, F. Lu, H. Zhang, J. Sun, and C. C. Mi, “A real-time battery thermal management strategy for connected and automated hybrid electric vehicles (CAHEVs) based on iterative dynamic programming,” *IEEE Transactions on Vehicular Technology*, vol. 67, no. 9, pp. 8077–8084, 2018.
- [27] R. Liessner, A. Lorenz, J. Schmitt, A. M. Dietermann, and B. Baker, “Simultaneous electric powertrain hardware and energy management optimization of a hybrid electric vehicle using deep reinforcement learning and Bayesian optimization,” in *2019 IEEE Vehicle Power and Propulsion Conference (VPPC)*, pp. 1–6, Hanoi, Vietnam, 2019.
- [28] S. Yang, M. Li, B. Xu, B. Guo, and C. Zhu, “Optimization of fuzzy controller based on genetic algorithm,” in *2010 International Conference on Intelligent System Design and Engineering Application*, pp. 21–28, Changsha, 2010.
- [29] Y. Cheng, C. Lai, and J. Teh, “Optimization of control strategy for hybrid electric vehicles based on improved genetic algorithm,” in *2017 IEEE Vehicle Power and Propulsion Conference (VPPC)*, pp. 1–4, Belfort, 2017.
- [30] M. Yue, S. Jemei, and N. Zerhouni, “Health-conscious energy management for fuel cell hybrid electric vehicles based on prognostics-enabled decision-making,” *IEEE Transactions on Vehicular Technology*, vol. 68, no. 12, pp. 11483–11491, 2019.
- [31] S. Uebel, N. Murgovski, B. Bäker, and J. Sjöberg, “A two-level MPC for energy management including velocity control of hybrid electric vehicles,” *IEEE Transactions on Vehicular Technology*, vol. 68, no. 6, pp. 5494–5505, 2019.
- [32] S. Nazari, J. Siegel, and A. Stefanopoulou, “Optimal energy management for a mild hybrid vehicle with electric and hybrid engine boosting systems,” *IEEE Transactions on Vehicular Technology*, vol. 68, no. 4, pp. 3386–3399, 2019.
- [33] G. Celli, E. Ghiani, F. Pilo, G. Pisano, and G. G. Soma, “Particle swarm optimization for minimizing the burden of electric vehicles in active distribution networks,” in *2012 IEEE Power and Energy Society General Meeting*, pp. 1–7, San Diego, CA, 2012.
- [34] M. Zhou, H. Zhang, and X. Wang, “Research on fuzzy energy management strategy of parallel hybrid electric vehicle,” in *Proceedings of 2011 International Conference on Electronic & Mechanical Engineering and Information Technology*, pp. 967–971, Harbin, 2011.
- [35] J. Qi, C. Lai, B. Xu, Y. Sun, and K. Leung, “Collaborative energy management optimization toward a green energy local area network,” *IEEE Transactions on Industrial Informatics*, vol. 14, no. 12, pp. 5410–5418, 2018.
- [36] S. Xie, S. Qi, and K. Lang, “A data-driven power management strategy for plug-in hybrid electric vehicles including optimal battery depth of discharging,” *IEEE Transactions on Industrial Informatics*, vol. 16, no. 5, pp. 3387–3396, 2020.
- [37] A. A. Ferreira, J. A. Pomilio, G. Spiazzi, and L. de Araujo Silva, “Energy management fuzzy logic supervisory for electric vehicle power supplies system,” *IEEE Transactions on Power Electronics*, vol. 23, no. 1, pp. 107–115, 2008.
- [38] W. Lee, H. Jeoung, D. Park, and N. Kim, “An adaptive concept of PMP-based control for saving operating costs of extended-range electric vehicles,” *IEEE Transactions on Vehicular Technology*, vol. 68, no. 12, pp. 11505–11512, 2019.
- [39] Q. Zhang and G. Li, “Experimental study on a semi-active battery-supercapacitor hybrid energy storage system for electric vehicle application,” *IEEE Transactions on Power Electronics*, vol. 35, no. 1, pp. 1014–1021, 2020.
- [40] H. N. de Melo, J. P. F. Trovão, P. G. Pereira, H. M. Jorge, and C. H. Antunes, “A controllable bidirectional battery charger for electric vehicles with vehicle-to-grid capability,” *IEEE Transactions on Vehicular Technology*, vol. 67, no. 1, pp. 114–123, 2018.
- [41] J. Chen, C. Xu, C. Wu, and W. Xu, “Adaptive fuzzy logic control of fuel-cell-battery hybrid systems for electric vehicles,” *IEEE Transactions on Industrial Informatics*, vol. 14, no. 1, pp. 292–300, 2018.
- [42] M. A. Ali and D. Soffker, “Towards optimal power management of hybrid electric vehicles in real-time: a review on methods, challenges, and state-of-the-art solutions,” *Energies*, vol. 11, no. 3, pp. 1–24, 2018.
- [43] Q. Li, T. Wang, C. Dai, W. Chen, and L. Ma, “Power management strategy based on adaptive droop control for a fuel cell-

- battery-Supercapacitor hybrid tramway,” *IEEE Transactions on Vehicular Technology*, vol. 67, no. 7, pp. 5658–5670, 2018.
- [44] P. G. Anselma, Y. Huo, J. Roeleveld, G. Belingardi, and A. Emadi, “Slope-weighted energy-based rapid control analysis for hybrid electric vehicles,” *IEEE Transactions on Vehicular Technology*, vol. 68, no. 5, pp. 4458–4466, 2019.
- [45] T. Liu, X. Tang, H. Wang, H. Yu, and X. Hu, “Adaptive hierarchical energy Management Design for a Plug-in Hybrid Electric Vehicle,” *IEEE Transactions on Vehicular Technology*, vol. 68, no. 12, pp. 11513–11522, 2019.
- [46] Y. Zou, Z. Kong, T. Liu, and D. Liu, “A real-time Markov chain driver model for tracked vehicles and its validation: its adaptability via stochastic dynamic programming,” *IEEE Transactions on Vehicular Technology*, vol. 66, no. 5, pp. 3571–3582, 2017.
- [47] L. Li, S. You, C. Yang, B. Yan, J. Song, and Z. Chen, “Driving-behavior-aware stochastic model predictive control for plug-in hybrid electric buses,” *Applied Energy*, vol. 162, pp. 868–879, 2016.
- [48] Z. Chen, R. Xiong, and J. Cao, “Particle swarm optimization-based optimal power management of plug-in hybrid electric vehicles considering uncertain driving conditions,” *Energy*, vol. 96, pp. 197–208, 2016.
- [49] C. Sun, F. Sun, and H. He, “Investigating adaptive-ecms with velocity forecast ability for hybrid electric vehicles,” *Applied Energy*, vol. 185, pp. 1644–1653, 2017.
- [50] T. Liu, Y. Zou, D. Liu, and F. Sun, “Reinforcement learning of adaptive energy management with transition probability for a hybrid electric tracked vehicle,” *IEEE Transactions on Industrial Electronics*, vol. 62, no. 12, pp. 7837–7846, 2015.
- [51] C. Capasso, D. Lauria, and O. Veneri, “Optimal control strategy of ultra-capacitors in hybrid energy storage system for electric vehicles,” *Energy Procedia*, vol. 142, pp. 1914–1919, 2017.
- [52] H. Zhang, X. Li, X. Liu, and J. Yan, “Enhancing fuel cell durability for fuel cell plug-in hybrid electric vehicles through strategic power management,” *Applied Energy*, vol. 241, pp. 483–490, 2019.
- [53] Y. Wang, Z. Sun, and Z. Chen, “Energy management strategy for battery/supercapacitor/fuel cell hybrid source vehicles based on finite state machine,” *Applied Energy*, vol. 254, 2019.
- [54] S. Zhang, R. Xiong, and J. Cao, “Battery durability and longevity based power management for plug-in hybrid electric vehicle with hybrid energy storage system,” *Applied Energy*, vol. 179, pp. 316–328, 2016.
- [55] C. Robin, M. Gerard, M. Quinaud, J. Darbigny, and Y. Bultel, “Proton exchange membrane fuel cell model for aging predictions: simulated equivalent active surface area loss and comparisons with durability tests,” *Journal of Power Sources*, vol. 326, pp. 417–427, 2016.
- [56] V. Larsson, L. Johannesson, and B. Egardt, “Analytic solutions to the dynamic programming subproblem in hybrid vehicle energy management,” *IEEE Transactions on Vehicular Technology*, vol. 64, no. 4, pp. 1458–1467, 2015.
- [57] Y. Yang, H. Pei, X. Hu, Y. Liu, C. Hou, and D. Cao, “Fuel economy optimization of power split hybrid vehicles: a rapid dynamic programming approach,” *Energy*, vol. 166, pp. 929–938, 2019.
- [58] P. Elbert, S. Ebbesen, and L. Guzzella, “Implementation of dynamic programming for n-dimensional optimal control problems with final state constraints,” *IEEE Transactions on Control Systems and Technology*, vol. 21, no. 3, pp. 924–931, 2013.
- [59] W. Zhou, L. Yang, Y. Cai, and T. Ying, “Dynamic programming for new energy vehicles based on their work modes part i: electric vehicles and hybrid electric vehicles,” *Journal of Power Sources*, vol. 406, pp. 151–166, 2018.
- [60] Y. Li, H. He, J. Peng, and H. Zhang, “Power management for a plug-in hybrid electric vehicle based on reinforcement learning with continuous state and action spaces,” *Energy Procedia*, vol. 142, pp. 2270–2275, 2017.
- [61] S. Zhang and R. Xiong, “Adaptive energy management of a plug-in hybrid electric vehicle based on driving pattern recognition and dynamic programming,” *Applied Energy*, vol. 155, pp. 68–78, 2015.
- [62] S. Zhang, R. Xiong, and F. Sun, “Model predictive control for power management in a plug-in hybrid electric vehicle with a hybrid energy storage system,” *Applied Energy*, vol. 185, pp. 1654–1662, 2017.
- [63] R. Xiong, J. Cao, and Q. Yu, “Reinforcement learning-based real-time power management for hybrid energy storage system in the plug-in hybrid electric vehicle,” *Applied Energy*, vol. 211, pp. 538–548, 2018.
- [64] S. Ahmadi, S. M. T. Bathaee, and A. H. Hosseinpour, “Improving fuel economy and performance of a fuel-cell hybrid electric vehicle (fuel-cell, battery, and ultra-capacitor) using optimized energy management strategy,” *Energy Conversion and Management*, vol. 160, pp. 74–84, 2018.
- [65] Q. Zhang, W. Deng, and G. Li, “Stochastic control of predictive power management for battery/supercapacitor hybrid energy storage systems of electric vehicles,” *IEEE Transactions on Industrial Informatics*, vol. 14, no. 7, pp. 3023–3030, 2018.
- [66] Z. Zhang, C. Guan, and Z. Liu, “Real-time optimization energy management strategy for fuel cell hybrid ships considering power sources degradation,” *IEEE Access*, vol. 8, pp. 87046–87059, 2020.
- [67] O. Salari, K. H. Zaad, A. Bakhshai, and P. Jain, “Filter design for energy management control of hybrid energy storage systems in electric vehicles,” in *2018 9th IEEE International Symposium on Power Electronics for Distributed Generation Systems (PEDG)*, pp. 1–7, Charlotte, NC, 2018.
- [68] J. J. Mwambeleko and T. Kulworawanichpong, “Battery and accelerating-catenary hybrid system for light rail vehicles and trams,” in *2017 International Electrical Engineering Congress (iEECON)*, pp. 1–4, Pattaya, 2017.
- [69] S. R. Marjani, M. Gheibi, V. Talavat, and M. Farsadi, “A novel hybrid intelligent method for static var compensator placement in distribution network with plug-in hybrid electrical vehicles parking,” in *2015 Intl Aegean Conference on Electrical Machines Power Electronics (ACEMP), 2015 Intl Conference on Optimization of Electrical Electronic Equipment (OPTIM) 2015 Intl Symposium on Advanced Electromechanical Motion Systems (ELECTROMOTION)*, pp. 323–330, Side, Turkey, 2015.
- [70] M. A. Saeed, N. Ahmed, M. Hussain, and A. Jafar, “A comparative study of controllers for optimal speed control of hybrid electric vehicle,” in *2016 International Conference on Intelligent Systems Engineering (ICISE)*, pp. 1–4, Islamabad, 2016.
- [71] J. Solano, D. Hissel, and M. Pera, “Energy management of an hybrid electric vehicle in degraded operation,” in *2014 IEEE Vehicle Power and Propulsion Conference (VPPC)*, pp. 1–4, Coimbra, 2014.
- [72] Q. Xu, S. Varadarajan, C. Chakrabarti, and L. J. Karam, “A distributed canny edge detector: algorithm and FPGA

- implementation,” *IEEE Transactions on Image Processing*, vol. 23, no. 7, pp. 2944–2960, 2014.
- [73] S. N. Shirazi, A. Gouglidis, A. Farshad, and D. Hutchison, “The extended cloud: review and analysis of mobile edge computing and fog from a security and resilience perspective,” *IEEE Journal on Selected Areas in Communications*, vol. 35, no. 11, pp. 2586–2595, 2017.
- [74] T. Bahreini, M. Brocanelli, and D. Grosu, “Energy-aware resource management in vehicular edge computing systems,” in *2020 IEEE International Conference on Cloud Engineering (IC2E)*, pp. 49–58, Sydney, Australia, 2020.
- [75] Y. Cao, H. Song, O. Kaiwartya et al., “Mobile edge computing for big-data-enabled electric vehicle charging,” *IEEE Communications Magazine*, vol. 56, no. 3, pp. 150–156, 2018.
- [76] D. Ahmad, S. Z. Hassan, A. Zahoor et al., “A bidirectional wireless power transfer for electric vehicle charging in V2G system,” in *2019 International Conference on Electrical, Communication, and Computer Engineering (ICECCE)*, pp. 1–6, Swat, Pakistan, 2019.
- [77] Z. Lv, H. Song, P. Basanta-Val, A. Steed, and M. Jo, “Next-generation big data analytics: state of the art, challenges, and future research topics,” *IEEE Transactions on Industrial Informatics*, vol. 13, no. 4, pp. 1891–1899, 2017.
- [78] X. Xu, B. Shen, S. Ding et al., “Service offloading with deep Q-network for digital twinning empowered Internet of Vehicles in edge computing,” *IEEE Transactions on Industrial Informatics*, 2020.
- [79] C. Chen, Y. Zhang, M. R. Khosravi, Q. Pei, and S. Wan, “An intelligent platooning algorithm for sustainable transportation systems in smart cities,” *IEEE Sensors Journal*, 2020.