

## Research Article

# Efficient Energy Utilization Algorithm through Energy Harvesting for Heterogeneous Clustered Wireless Sensor Network

Masresha Getahun,<sup>1</sup> M. Azath ,<sup>2</sup> Durga Prasad Sharma ,<sup>3</sup> Amin Tuni,<sup>2</sup> and Abel Adane<sup>4</sup>

<sup>1</sup>Information Communication Technology, Arba Minch College of Teachers Education, Arba Minch, Ethiopia

<sup>2</sup>Faculty of Computing and Software Engineering, Arba Minch University, Ethiopia

<sup>3</sup>MSRDC-MAISM (RTU), Research Centre Jaipur & AMUIT, MOEFDRE under UNDP, Ethiopia

<sup>4</sup>Faculty of Computing & Software Engineering, Arba Minch University, Ethiopia

Correspondence should be addressed to M. Azath; [azathhussain@gmail.com](mailto:azathhussain@gmail.com)

Received 21 December 2021; Revised 14 February 2022; Accepted 2 March 2022; Published 4 April 2022

Academic Editor: Narasimhan Venkateswaran

Copyright © 2022 Masresha Getahun et al. This is an open access article distributed under the Creative Commons Attribution License, which permits unrestricted use, distribution, and reproduction in any medium, provided the original work is properly cited.

The usefulness of wireless sensor networks has fascinated the world's attention. Usage of low-power microcontrollers and wireless sensors to handle real-world problems such as environmental, medicinal, and structural monitoring has exploded. Wireless sensor nodes are extremely tiny and are designed for low-duty applications such as recording physical characteristics. Wireless sensor network operations such as sensing, calculations, and communication take extensively more energy than these low-powered sensor nodes. They are used both in attainable and inaccessible areas and are usually powered by batteries. Since the sensor is powered by batteries, replacing and charging the battery after its depletion are challenging. Manual battery replacement is hampered by geographical restrictions, which results in significant reduction of wireless sensor network performance and longevity. As a result, this study addresses the energy-constrained wireless sensor networks by creating a technological model to a heterogeneous clustered wireless sensor network in an outdoor application using solar-enabled energy harvesting photovoltaic cells. Due to lack of energy, this effort was employed to overcome the challenges of relatively restricted processing performance and limited radio frequency transmission bandwidth. The program was created to efficiently utilize the energy produced from solar panels and charge the batteries in a variety of ways. The algorithm also controls the discharging process. According to the results of extensive investigation and experimentation, the sensor is continuously operated even when there is no solar light. The batteries are charged on bright day and discharged at night and on overcast days. The algorithm is used to govern the energy supplement to rechargeable lithium-ion polymer batteries as well as a load (sensor). In the worst scenario (no solar light/cloudy, and sensors reporting data every 30 minutes), the present cluster head sensor with 6 ordinary nodes in the cluster lasts just 16.6667 days. But the life duration of the newly designed model algorithm has been raised to 54.16667 days. The normal sensor node's life duration has also been enhanced from 50 to 91.66667 days.

## 1. Introduction

Wireless sensor network (WSN) is evolving as both vital and new tier in the IT ecology. It consists of emphatically large number of low power multifunctional tiny devices called sensor nodes and has sense, computation and communication ability. To handle these properties, there are some basic micro electro mechanical components of sensors such as analog to digital converter (ADC), a CPU, a power unit, and a communication unit. WSN became a reality due to

colossal advancements in micro-electrical-mechanical systems (MEMS) and radio communication technology. Sensor nodes are positioned in bulky scale that runs independently. These small devices are embedded with sensors named as "nodes" with proficiency to feel the real world.

A wireless sensor network is basically a circuitry of tiny devices called sensors that can sense the physical environment. The main distinctiveness of WSNs is flexibility, maintainability, scalability, self-monitoring, and property of fault tolerance. Moreover, it is capable to accomplish its duty even

in harsh environment. When compared with other networks, the services provided by wireless sensor network are in real time and reliable [1].

The WSN is typically an ad hoc network. Once the sensors are set up, the nodes self-organize itself in the network. The nodes are positioned distantly in an unattended environment. The placements are either fixed or random. In a fixed deployment, the position or location of node placement is determined, and in a random deployment, the nodes are deployed arbitrarily in the network, and location is not determined.

Energy is the most important source to carry out every operation in a wireless sensor network. Every node needs energy because the size of the node and the design of the sensor network directly depend on the potential energy issues with communication capability, computation, and storage capacity. Reducing energy depletion has become a major concern in wireless sensor networks.

WSN design is influenced by sensor node performance, clustering of sensor node, mobility of sensor node in the network, security, and power utilization. To efficiently design and manage, structural wireless sensor networks are classified as homogenous and heterogeneous. In homogeneous WSN system, all nodes have same sensing, computing, and storing capability, and nodes drain their energy uniformly which is a critical problem for the network life of WSN. All nodes will lose or drain their energy which collapses the whole network life. In heterogeneous system, WSN scheme nodes with dissimilar proficiency are used with respect to battery, storage, and mobility processing. The benefit of such heterogeneity is that the life span of network can be increased and the mastery roles of the network can be handled by nodes with high energy called cluster head. Nodes with low energy can be used for sensing the environment, hence making the network more efficient in terms of energy.

To manage the heterogeneous WSN in effective way, nodes can be grouped into nonoverlapping groups called cluster. Each of these clusters is led by a cluster head that manages the activities and schedules the nodes that are members of the cluster. The cluster head is either selected or predetermined. In heterogeneous WSN, the nodes with high energy is considered as the cluster head candidate, and nodes with less energy are for sensing. This is a very important technique to save the energy sensor node.

Different algorithms and protocols have been proposed to overcome the problem of power consumption in cluster heterogeneous wireless sensor networks. Algorithms have been proposed for distributed energy saving clustering (DEEC), the development of distributed energy saving clustering (DDEEC), enhanced distributed energy saving clustering (EDEEC), and clustering in threshold distributed power saving (TDEEC) clusters. The main purpose of these algorithms is to save energy and extend the life of the network.

In WSN, energy utilization is the most dominant issue which influences the node performance and the network life both directly and indirectly. During the operation time, every electro mechanical parts of the sensor node utilizes the energy which is continuously and sustainably needed for node parts like sensor part, analog data to digital conver-

tor part, processor part, storage unit, and communication part. The whole network life of WSN directly depends on the power sustainability. Power consumption constrains for nodes are the critical problem since they have used batteries or energy harvesting mechanism. WSN is usually battery operated (rechargeable or nonrechargeable) or an embedded form of energy harvesting. Since these nodes are deployed in unreachable sites, replacing the batteries every now and then is a tedious job.

As an objective, the intention of this research is to increase the efficiency of energy utilization by developing an algorithm and the model electromechanical parts of the sensor node. The function of the node will be both battery enabled and power harvesting mechanism, to recharge the battery and make the sources of energy sustainable. Clustering design and heterogeneous architecture are selected for the WSN since they are very important to conserve the energy for the node. A wireless sensor network requires energy to perform any function since it is one of the most demanding factors that influences the system's cost, longevity, and energy consumption. In this real-time context, there is a scarcity of energy platforms to carry out additional tasks.

The algorithm is to be tested in a simulated environment. The simulation technique is used for designing the algorithm, and further it can be tested with special reference to any territory having deployed wireless sensor networks selected for target study, analysis, and functional validation. The expected results of this research will be efficient energy utilizing in terms of power saving and recovering the sustained energy source and to prolong the life of the network.

## 2. Statement of the Problem

A wireless sensor network needs energy to carry out any operation as it is one of the most demanding factor which affects the cost, lifetime, and energy consumption of the system. A sensor node (i.e., a temperature and humidity node) powered by a 5000 mAh Li-ion polymer battery has a capacity of 50 days and consumes 26095.53 J of energy. This node can send and receive 2 KB of data at a time with a nearby node. If this node serves as the network's cluster head node, it has a life span of 16.667 days and uses 26068.7 J of energy. Because traffic near the cluster head is heavy so more energy is wasted from the node. This energy shortfall will bring the entire network to a halt. However, when the node is in complicated and continuous operation, the energy is depleted, and the energy storage (battery) is depleted. This halts sensor function, causing the nodes to shut down.

The nodes are set up remotely in such a way so that they are both reachable and unreachable. The deployment might be either predetermined or purposeless. Because of the inaccessibility (random deployment of nodes) to a significant number of sensor nodes, replacing nodes and recharging batteries are impractical.

Clustered heterogeneous wireless sensor network protocols have three layers of network in terms of stability period and network life span. Normal, advanced, and super nodes are the three network tiers. When compared to standard and advanced nodes, super nodes have greater energy level.

A clustered network's basic components are the base station (BS) node, the cluster head (CH) node, and the normal nodes. All data from the sensor network is transferred to the base station via cluster. Since there is more traffic near the base station, the sensor nodes in these locations run out of power. When the base station is disconnected, all remaining energy stored in other sensor nodes (doi.org/) are drained out. If the node functions constantly in the network, the energy spent by all level sensor nodes (normal, advanced, and super) cannot be recovered.

To address these issues, the researchers put forward the idea of solar-powered prototype sensor nodes as an alternate energy source for the sensor node. The energy gathered from solar, thermal, and vibration sources is incorporated in the sensor node, potentially increasing the node energy autonomy dramatically. When the energy source (solar) is unavailable, such as at night or on overcast days, the sensor node experiences energy under flow. When the energy storage is full, the captured energy cannot be stored, resulting in energy overflow to the sensor node or waste. The desideratum of this research is to create a novel model and an algorithm that will boost the efficiency of energy used by the sensor node by enabling active solar energy harvesting with photovoltaic cells. The gathered energy is used to load and charge the batteries immediately.

The researchers forwarded the following research questions with consideration of the issues cited in the statement of problems:

- (1) What is a technique solution for solar-powered wireless sensor node to efficiently utilize energy and prolong their lifetime?
- (2) How to manage wireless sensor node's energy overflow and underflow during energy harvesting from solar?

### 3. Scope and Limitation of the Study

The main focus of the research study is to examine the heterogeneous clustered wireless sensor network in reference to energy utilization of sensor node features. Energy is the critical issue in wireless sensor network that limits the performance of memory, processing capacity, and communication capabilities' of sensor node. High performance computing capabilities and affordability are most important issues. The study focuses only in rechargeable battery enabled and solar energy harvesting techniques for potential exploitation of efficient energy utilization over heterogeneous clustered wireless sensor network using three parameters, i.e., high performance computing, sustaining network life, and cost effectiveness that could be used as a baseline for implementation in deploying wireless sensor node in any application area. This research is also limited to use secondary data for experimental analysis to figure out the results. Because of the shortage or unavailability of sensor nodes applicability, this research is limited to be tested in simulated fashion only.

### 4. Literature Review

Different researchers indicate that the EH (energy harvesting) circuit should stay constantly active to catch energy. The energy consumed by the harvester circuit must be terribly little when compared to the energy provided by the close sources. Conjointly, the EH circuit should be able to store the harvested energy with minimum leakage. The energy that is harvested from the sun is employed by an electrical phenomenon technique. Electrical phenomenon is a technique of changing solar power into electrical energy. The importance of the system lies in the solar cell, electric receptacle hunter or maximum power point tracker (MPPT), and voltage converter. The utmost power is extracted from the electric cell by matching the electric resistance of the star cell and then to the transformer or converter. In step with investigator Trong Nhan LE, the facility density of PV-direct sun is  $15 \text{ mW/cm}^2$ , PV-cloudy day is  $0.15 \text{ mW/cm}^2$ , PV-indoor is  $6 \mu\text{W/cm}^2$ , and PV table lamp is  $0.57 \text{ mW/cm}^2$ . The energy that is harvested by solar or photovoltaic cell yields around  $15 \text{ mW/cm}^2$  fully daylight or  $0.006 \text{ mW/cm}^2$  below bright indoor illumination. The energy which is generated by electricity with  $1000^\circ\text{C}$  temperature is  $40 \mu\text{W/cm}^2$  of power, and  $330 \mu\text{W/cm}^2$  is generated from mechanical vibrations [2]. So, energy harvesting or power scavenging for the wireless device node is best fitted to applications that require continuous provider of low power, or the applications that need high power for a tiny low period of time. Every sensor node part (processor, sensor board, memory, radio, sensor unit, ADC) consumes a power during its real-time operation from the supplied battery. Although recent research focuses strongly on energy-aware applications and operating systems, energy consumption is still a limiting factor.

In 2011, S. Barani and C. Gomathy worked on power aware heterogeneous wireless sensor network. The research mainly focused on the power management of the sensor nodes in the network. The entire network's power utilization was analyzed based on its node's battery power at various scenarios, and the network lifetime was calculated based on the power consumed by the network at the end of each transmission. The researchers used temperature and pressure sensor node to estimate or calibrate the energy consumption per day and the life time of the whole network. According to the researchers, the total energy consumed by a single node (temperature) is 16,074.85 joules/day, and total energy consumed by a single node (pressure) is 5706.85 joules/day. Based on these facts, the life time of temperature node is 1.6 hours, and lifetime of pressure node is 4.73 hours.

In 2012, Somov et al. worked on "energy-aware gas sensing using wireless sensor networks." The result of average power consumption is 1.45 mW and 2.64 mW for the gas sensor and the sensor node, respectively. With researcher techniques, the sensor node lifetime was enriched from 187 days to 641 days.

In 2015, Olaf Landsiedel, Klaus Wehrle, and Stefan Gotz worked on "Precise Prediction of Power Consumption in Sensor Networks." In that the researchers discussed the basic concepts of energy consumption and objection of exactly

evaluating and predicating energy depilated in every sensor node parts.

Wireless sensor networks pose huge challenges in terms of implementation. Designers must carefully consider several key attributes, which are particularly important in wireless sensor networks, including cluster cost, cluster head and cluster selection, real-time operation, synchronization, data aggregation, repair mechanism, and quality of service. Clustering technique is the key technique for decreasing high energy nodes in which members of cluster select a cluster head (CH). There will be no communication between the nodes and base station (BS) due to long distance and limited battery as direct communication requires high energy [3], and the data might be lost due to energy shortage.

According to the researcher, WSNs are generally setup in natural, unattended, and uncontrolled environment. Development of network dynamics like topology, routing, and security based on WSN is influenced by the vitality of the nodes. Nodes are operated by a low battery and so the energy may easily get exhausted if any complex operations are performed by nodes [4]. To overcome this problem, the researchers proposed ZigBee as a solution, low-cost, low-power suite of high-level protocols. It does not require any access point and is mainly used to monitor or to control tasks that require low cost, reliability, security, and low power consumption (long battery life) and does not require high-range or high-speed communication. But still there is no constant energy harvesting technique to develop the energy as soon as it gets drains. The problem of network life is not fully addressed.

The researchers pointed out that the sensors need an effective energy utilization mechanism to increase the lifetime of sensors in wireless sensor networks. In order to use energy efficiently, communication protocols play an important role. The design goal of these protocols is to avoid unnecessary data transmission and reception. For this reason, when there is no data to send or receive, the node is switched to idle or idle mode. In order to effectively utilize the energy resources of CHWSN (clustered heterogeneous wireless sensor network), many routing protocols have been proposed. Energy Efficiency Stable Choice Protocol (EESCP) is one of those protocols which are used to increase the active nodes, thereby improving the energy efficiency, stability period and service life of the network, and balancing energy consumption CHWSN (C. [5]). But, the sustainability of the energy source is not fully solved. The protocol is just to increase the efficiency of energy utilization by a sensor node. Those nodes which are continuously operating in the network will still lose or drain their energy.

Different researchers develop different techniques to save energy consumption of the WSNs. In 2011, a popular technique was established to ingather energy for implantable biosensors. The researcher discussed the advantages and disadvantages of the energy harvesting techniques. Stress retained on the preliminary links to transport energy wirelessly through the biological tissues and empower bidirectional data communication with the implanted sensors [6]. Finally, high frequency inductive associations were entitled, also focusing on the energy attracted by the tissues.

Wireless sensor network (WSN) is an effective and efficient technology for field information. To fulfill the requirements of a realistic WSN system, a multiheterogeneity WSN scenario with sensor nodes having different initial energies and different traffic requirements along with solar energy-harvesting capabilities was considered. The proposed algorithm, energy harvesting, traffic, and energy aware routing, improves the WSN stability period over existing routing algorithms under the scenario, where the stability period indicates the WSN lifetime till all the nodes are alive and represent the most reliable period of an operational WSN [7].

The researchers address the issue of energy for long positioning of available invasion over sensor network systems, energy aggregation to achieve maximum its new potential to develop a wireless power sensor network (WPSN) system deeply embedded with a task scheduling, and to operate as a nonorthogonal multiple access (NOMA) system. The proposed meta-heuristic-based WPSN system is validated through simulation data presented in this work by analyzing, evaluating, and comparing it to benchmark state-of-the-art WPSN systems that coupled a metaheuristic algorithm, two additional metaheuristic algorithms such as genetic algorithm (GA) and ant-colony optimization (ACO) algorithm, and also a non-meta-heuristic algorithm specifically an iterative based Dinkelbach algorithm [8].

In a separate study, the researchers suggest a hybrid strategy usage of mobile sink, firefly algorithm based on leach, and Hopefield Neural Network (WSN-FAHN). As a result, mobile sink is used to reduce energy usage while also increasing network life span [9].

A technique is described by [10] that uses the firefly algorithm and the four parameters of residual energy, noise rate, number of hops, and distance. The suggested technique EM-FIREFLY is introduced, which picks the finest cluster head with high attraction and transmits packets of data through these cluster heads to the sink using the fitness function.

The suggested REACH method (Residual Energy Adaptive Cluster Head Selection Algorithm) simplifies the cluster building procedure. REACH focuses on the establishment of uniform energy-based clusters for effective energy management. In terms of life duration and dead node ratio, simulation findings reveal that REACH outperforms hetero Stable Election Protocol (SEP) and homogeneous Low Energy Adaptive Clustering Hierarchy (LEACH) (Hitesh [11]).

The key focus of this research paper is to propose a cost-effective solar energy harvesting resolution to the WSN node's battery capacity energy problem by harnessing ambient sun photovoltaic energy. The nodes of the Optimized Solar Energy Harvesting Wireless Sensor Network (SEH-WSN) should ideally run indefinitely (in years). We present a unique and efficient solar energy harvesting method for WSN nodes in this research, using pulse width modulation (PWM) and maximum power point tracking (MPPT). The goal of the research is to improve total harvesting system efficiency, which is dependent on solar panel efficiency, PWM efficiency, and MPPT efficiency. Various models for solar energy harvester systems are constructed, and iterative simulations in MATLAB/SIMULINK for solar-powered DC-DC converters with PWM and MPPT were done to

reach the best results. According to the simulation findings, our developed solar energy harvesting system has 87 percent efficiency (hsys) when using PWM control and 96 percent efficiency (hsys) when utilizing the MPPT control approach. Finally, for confirmation of simulation results, an experiment for PWM driven SEH-WSN is undertaken utilizing a Science tech 2311 WSN trainer kit and a Generic LM2575 DC-DC buck converter-based solar energy harvesting module (Himanshu Sharma 1, 2018).

The authors suggested a hybrid bacterial foraging optimization (BFO) and fruitfully optimization algorithm (FOA) for energy efficient cluster head (CH) choosing in a wireless sensor network. The bacterial forage optimization technique is influenced by the collective browsing behavior of bacteria such as *E. coli* and *M. xanthus*, which recognizes chemical in the environment and avoids certain signals. The FOA is a basic framework that is straightforward to employ when addressing an optimization issue with various properties. It is a reliable and quick approach for solving discrete optimization problems. The suggested method's performance metrics are assessed for end-to-end latency, packet delivery, drop ratio, energy consumption, network lifetime, and throughput. The simulation results demonstrate that the suggested technique outperforms current methods such as ant colony optimization, particle swarm optimization, and genetic algorithm in terms of energy efficiency and network life span by 35%, 58%, and 67%, respectively [12].

When a sensor node's battery's available energy is spent, the sensor node becomes inactive in a network. As a result, such a node may be unable to engage in the transmission of the application signal during the network's uplink stage, resulting in a loss of ability to convey critical signals in a timely way. Energy shortage has long been an issue in wireless sensor network applications. This work considers energy harvesting from the planned RF power source to overcome this challenge. However, wireless powered wireless sensor network systems face resource allocation inequity as well as interference in various energy resource transfers. These issues have a negative influence on the system's performance in terms of collected energy by sensor nodes, sensor data transfer rates, and total system throughput rate. This study addresses these issues by defining a sum-throughput maximization problem to minimize system energy consumption while increasing system overall throughput rate.

The throughput optimization issue is denoted by a nonconvex function. It is turned to a convex function by utilizing the issue structure. Numerical simulations are used to validate the statistical formulas of the optimization issue [13].

Water-quality monitoring with WSN technology has emerged as an intriguing research topic. The paucity of energy is a key issue that impedes the widespread implementation of WSN systems. Various power sources that gather energy from renewable sources have been investigated. Whenever energy-efficient models are not implemented, energy harvesting-based WSN systems may have an unpredictable energy supply, resulting in communication interruptions and limited system throughput. To address these issues, this work uses a sum-throughput approach to maxi-

mize both the energy gathered by sensor nodes and its data throughput. By collecting energy from specific radio frequency sources, a wireless information and power transfer (WIPT) approach is investigated. A novel WIPT system is presented to increase the fairness of resource consumption in the network due to the double near-far situation that challenges WIPT methods. The results of numerical simulations are provided to evaluate the conceptual interpretations for the optimization issue, which optimize the energy gathered and the total throughput rate. The suggested WIPT system outperforms an existing state-of-the-art WIPT system when the performance parameters of possible throughput and fairness in resource sharing are defined, with the evaluation based on mathematical simulations of both systems [14].

In summary, the peer-reviewed article journals attempt to provide numerous techniques of energy harvesting, protocols, and algorithms to address the problem of energy scarcity in the sensor node. The energy captured from the sun and the environment is fed into the load to cover the void left by the battery's energy deficiency. The suggested protocols and algorithms attempt to limit wasteful energy dissipation and leakage by putting the sensor in idle, sleep, and active states. The source of energy is a significant aspect in extending the life of a sensor. The sensor receives power from both primary and secondary energy storage systems. Identifying a reliable, accessible, and long-lasting energy source for the sensor node is an important and difficult task in a wireless sensor network. The goal of this research study is to provide a technical model of a sensor node as well as an algorithm for economically utilizing energy in an effective manner in order to extend the life of a wireless sensor network. The researchers evaluated majority of the present research articles, where the existing studies are prone to numerous limitations; few publications aided the manuscript to increase the amount of collecting energy. As a result, this research will be extremely useful in the real-world setting to gather energy in worst climatic conditions such as no sunlight or hazy days.

## 5. Research Methodology

To attain general and specific objective of the research and to answer the research questions, the following research methodology was employed. The research design used for this study is quantitative as major and qualitative as minor for selected clustered heterogeneous wireless sensor network architecture and design. As a method, literature review, dataset selection, and experimentation are deployed. This study has used a methodical path of science to form and arbitrate an approach that creates and defines new modernism using qualitative or quantitative data [15].

*5.1. Dataset Selection.* A scopic literature review was carried out to get a deeper understanding of sensor node energy utilization, stretched life time, and solar energy harvesting techniques in heterogeneous clustered WSNs. Secondary data was collected from internationally recognized company's annual reports and article journals which focused on the Li-ion polymer battery's life time during discharging.

The life span of discharging the Li-ion polymer battery data was collected by direct observation using Internet as a medium.

**5.2. Experimentation.** The experiment was conducted prepensely on one cluster head sensor node and 6 ordinary nodes in a cluster in two phases due to budget and time constraint and manageability. The experimental analysis was conducted in simulation environment to generate a quantified data and to calculate the life span of a node in the wireless network.

The first phase experiment was conducted in case of average energy consumption of both cluster head and ordinary sensor node by counting the round of their real operation. Assuming that sensor's CPU, storage, radio transmitter, and receiver, analog to digital convertor and circuit board are partially or averagely consuming energy. As the real operation of sensor is increased, the depilation of energy is also increased. Alive node is a node with stored energy.

- (i) *Round vs. Alive Node with Solar Energy Harvesting on Clustered Heterogeneous.* WSN extracts data of the battery with the help of external energy harvesting mechanism to compare it with the sensor node having no external energy harvesting mechanism
- (ii) *Round vs. Alive Node with Battery Enabled Node on Clustered Heterogeneous.* WSN extracts data about the life of battery without the help of external energy harvesting mechanism
- (iii) *Round vs. Alive Node with Newly Proposed Model, Algorithms, and Techniques on Clustered Heterogeneous.* WSN extracts data with the help of external energy harvesting mechanism

The second experiment was conducted in case of the worst energy consumption. Assuming that sensors CPU, storage, radio transmitter, and receiver, analog to digital convertor is active and fully energy consuming.

- (i) *Round vs. Alive Node with Battery Enabled Node on Clustered Heterogeneous.* WSN extracts data about the life of battery without the help of external energy harvesting mechanism
- (ii) *Round vs. Alive Node with Solar Energy Harvesting on Clustered Heterogeneous.* WSN extracts data about the life of battery with the help of external energy harvesting mechanism to compare it with the sensor node having no external energy harvesting mechanism
- (iii) *Round vs. Alive Node with Newly Proposed Model, Algorithms, and Techniques on Clustered Heterogeneous.* WSN extracts data partially with the help of external energy harvesting mechanism

Each of the sensor node and the cluster head in a cluster consumes energy during the real operation. During operation, the energy is depilated from each ordinary sensor and

cluster head sensor node. The extracted data is analyzed in excel sheets and compared partially with the energy harvesting techniques to show the life span of each sensor node according to the energy accumulated and dissipated during real operation. With the same network structure and operation, but different techniques of energy harvesting and utilizing mechanism, the extracted data is analyzed quantitatively and qualitatively.

## 6. Proposed Model

To stress the scantiness of energy in ordinary and cluster head node, the researcher has proposed a new model of solar energy harvesting system. It is operated with accordance to the newly proposed algorithm. The paucity of energy in the sensor directly influences the sensor node's function. The whole wireless sensor network (WSNs) life is shown in Figure 1.

As an existing system, clustered wireless sensor network with accompanied solar energy harvesting system has been taken as reference. In this referenced network schema, data is reported to cluster head periodically and after 30 minutes to the cluster head node. Each battery has the potential to supply 26100.22 J of energy to the sensor. Charging and discharging of battery are controlled by the newly developed algorithm by referring the maximum and minimum threshold voltages of a battery.

The model harvest solar energy by PV solar panel is supplied to both load (sensor) and battery (Li-ion polymer) at the same time when direct sun light is available. At night time and cloudy days, the load consumes energy from the battery which is earlier charged by the solar panel. The model consists of three batteries for CH (cluster head) node and two pair of batteries for ordinary sensor node. In order to charge and discharge these batteries, the model is controlled and guided by microcontroller which uses an algorithm.

Energy is harvested from the solar panel, and this energy is directly delivered to the batteries and load with the help of energy regulator. The batteries are charged and discharged alternatively as shown in Figure 2.

The batteries used in this framework have maximum and minimum threshold with a value of 4.2 V and 2.70 V, respectively. When the power harvested from solar is terminated due to cloudy or night time, the frameworks automatically use power from the battery. The software and hardware parts of the sensor node work with the solar panel to harvest energy. Each hardware components which consumes energy in the sensor node is represented in Figure 3. The energy which is harvested from the solar is delivered to both the load (sensor) and the battery according to the newly proposed model.

The newly proposed model as shown in Figures 4 and 5 has two pairs of Li-ion polymer battery and solar panel. The energy harvested from the solar is supplied to both load and battery at the same time. The charging and discharging of the battery are controlled by the newly proposed algorithm. This technique manages the over flow and under flow of the harvested solar energy.

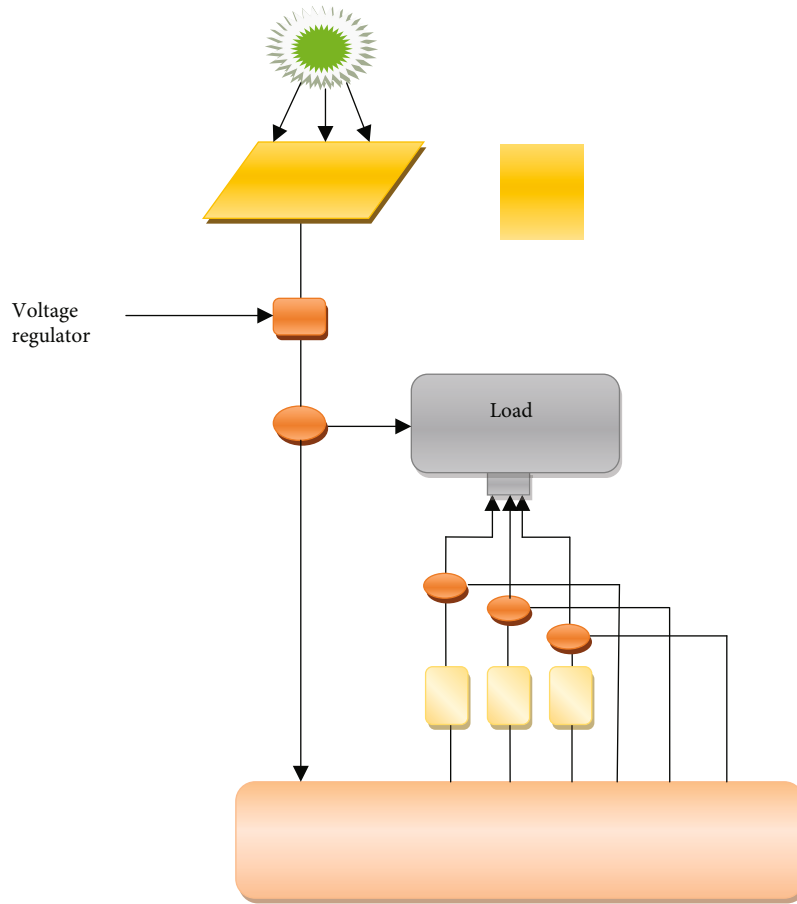

FIGURE 1: Proposed model for cluster head node.

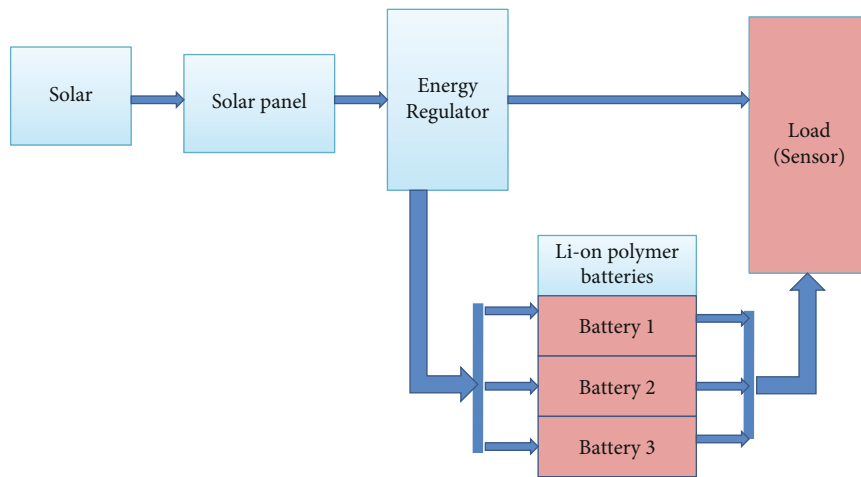

FIGURE 2: Proposed model architecture.

### 7. Proposed Algorithm

Several algorithms were proposed by different researchers to meet strict energy saving requirements. They are divided into location based: data-centric approach, mobility of nodes, multipath based, heterogeneity, and QoS-based algorithms with specific criterions. This research mainly focuses

on the Heterogeneity Algorithms with energy harvesting solar cell and to effectively save and utilize it. The newly proposed algorithm checks the battery voltage status in advance before charging. If the battery voltage is 2.75 V, then the microcontroller initiates (ON) the charger to pin. If the battery voltage reaches to maximum threshold of 4.2 V, then the pin which is earlier initiated is terminated (OFF). By using

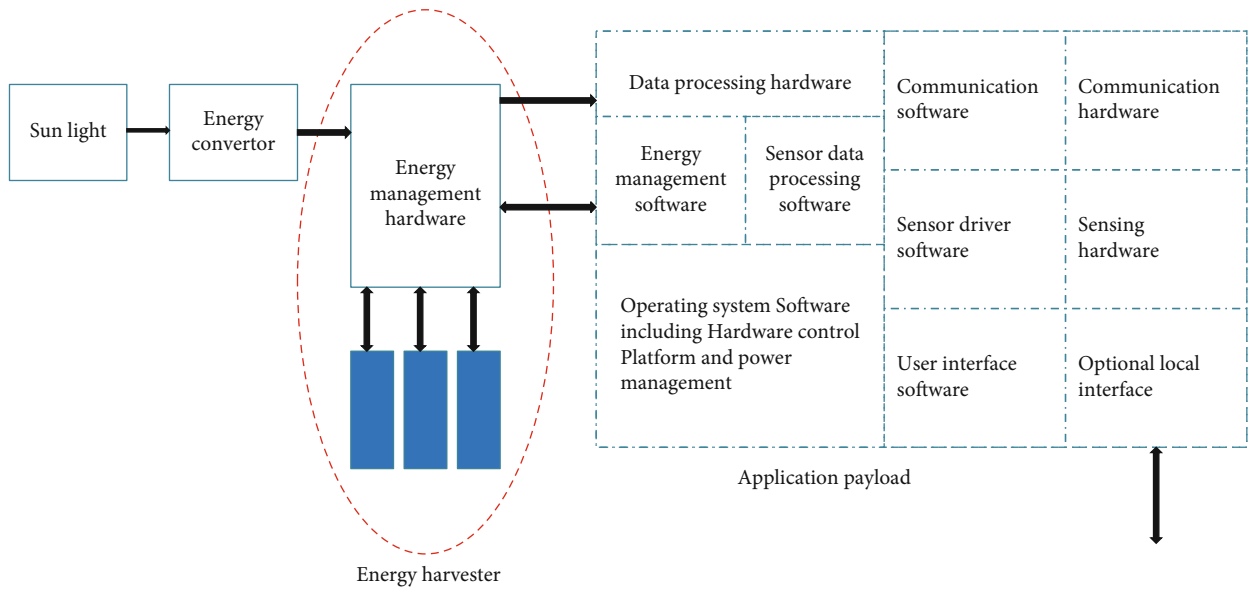

FIGURE 3: Sensor hardware and software components.

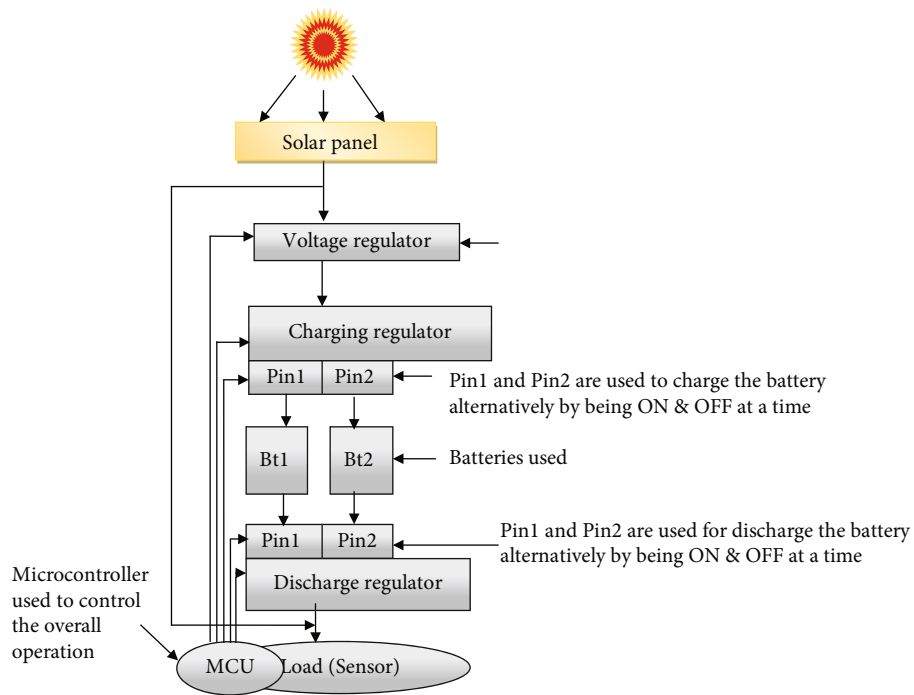

FIGURE 4: Proposed model architecture sensor node.

this principal technique, the next two batteries are charged alternatively. The working principle of the algorithm which charges the three batteries is stated as follows.

If sunny day

(1) Energy is directly supplied to load from solar

(2) Pin1 ON Charge → Bt1 by solar

If Bt1 full, then Pin 1 OFF

Pin 2 ON

(3) Pin 2 ON Charge → Bt2 by solar

If Bt2 full, then Pin 2 OFF

Pin 3 ON

(4) Pin 3 ON Charge → Bt3 by solar

If Bt3 full, then Pin 3 OFF



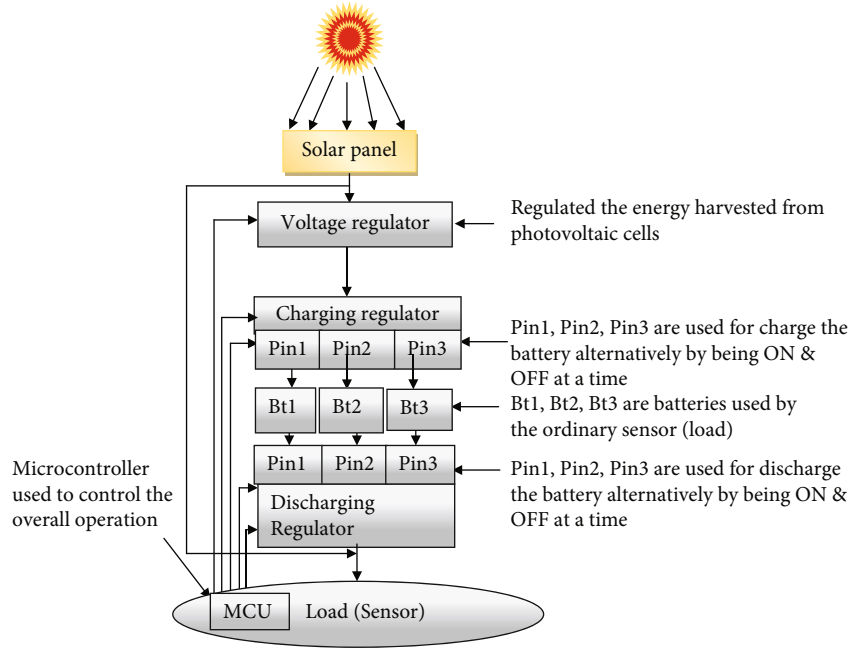

FIGURE 5: Proposed model architecture for CH node.

Then go to step 2

7.1. *Flow Chart of Charging Algorithm.* The flow chart of Figure 6 clearly indicates the work flow of the algorithm. The condition of the flow chart is checked on every step. It indicates every points of the algorithm. During the operation, the input and output values are clearly stated. The charging algorithm’s flow chart is given below.

## 8. Experimental Results

8.1. *Datasets during Experimentation.* In this blooming world, huge data are updated frequently so it is essential to scrutinize and acquire full knowledge from them [16]. Radio frequencies of a node should be active to receive and send packets from one node to another. The energy dissipated in transmitter amplifier in a free space channel  $\epsilon_{amp}$  and the energy of fusion  $\epsilon_f$  dissipated in interference and the fading are also considered in the research analysis. Table 1 shows each packet per energy values. This research was carried out using simulations in order to extend the battery life by charging it with both electrical and solar energy. The researchers employed varied energy levels for working with solar and electrical powers, which is mentioned in Tables 1 and 2. The research was completed through simulation-based work.

The amount of nodes that are positioned in the field and the size itself is one of the  $e$  critical factors that determine the dissipation of energy. Before analyzing the energy consumption of a single node, a determinant initial energy ( $E_o$ ) of every node in the cluster is evident. The number of node ( $n$ ) in the cluster and the distance ( $d$ ) between ordinary and cluster head (CH) is very crucial. Table 2 shows the cluster network assumptions values.

8.2. *Experimental Setup.* The experiment is conducted on the clustered heterogeneous wireless sensor node. The main duty is to experiment the lifetime of sensor in the network. The amount of energy peeled off from the sensor node is measured through repeated rounds of operation. During the experimentation, the existing system and the newly developed model are treated separately.

8.3. *Experimental Result and Discussion.* For experimental assay, the researchers take the following criterion to figure out the energy depilation of sensor hardware components, radio frequency, and the life times of the ordinary and cluster head sensor. They are round of operation ( $R$ ), initial energy of sensor ( $E_o$ ), energy consumed by sensor in idle state ( $E_i$ ), energy consumed by a sensor in active state ( $E_a$ ), energy of transmission of packet ( $E_{Tx}$ ), energy of receiving of a packet ( $E_{Rx}$ ), battery capacitance ( $C$ ), battery life ( $L$ ), distance between ordinary and cluster head node ( $d$ ), bits to be send ( $K$ ), and voltage required ( $V$ ). Sensor nodes should be both in active and idle state in order to manage their energy. The energy or current consumed during active and idle state is varied. The total energy which is consumed by the hardware components of sensor node in idle state and the current consumed by the hardware components of sensor node in active state is presented below.

The amount of voltage required to this sensor node hardware component is derived from a battery  $\Delta V = V_{max} - V_{min}$ . The maximum and minimum threshold of a sensor node’s battery is 4.2V and 2.75V, respectively. For example, the sensor’s CPU consumes  $1.9968 \times 10^{-6}$  J of energy in idle state within time elapse of 0.00042 seconds is shown in Table 3.

The experimental analysis in Figure 7 indicates that, when the sensor is in idle state, CPU and sensor board

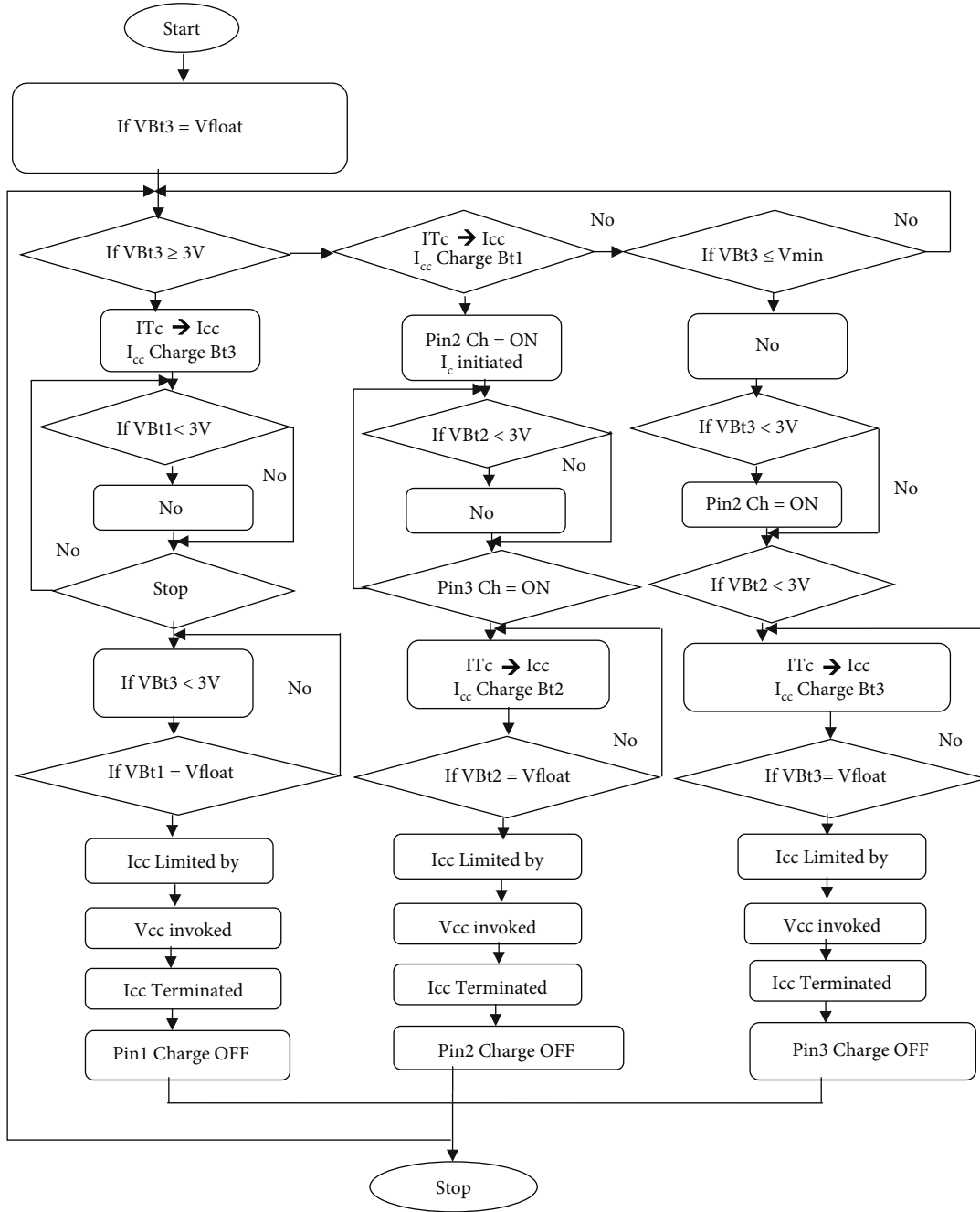

FIGURE 6: Flow chart of charging.

consume more energy than others. Sensor board and CPU work even in idle state. Since sensor gets active after every 30 minutes, all hardware components consume a significant energy. Above all, sensing (writing sensed data) and radio transceiver parts of sensor consume abundant energy.

8.4. Calculating Life Span of Sensor. The experimental results shown in Figure 8 reveal that the sensor consumes less energy in active state, which is active for about 63.44042 minutes and consumes 936.6257508 J of energy. Whereas in the state of idle, more energy is squandered from the sensor. Since the sensor node is in idle state for about 30

minutes as soon as it gets activated and reports data, it consumes more energy. According to the experimental analysis, the sensor stays idle for about 71936.56 minutes and consumes 25158.9036 J of energy. Generally, the total energy which is consumed by sensor in both active and idle state is 26095.53 J of energy.

In consonance with the above chart, the sensor dissipates more energy while in idle state. The experimental analysis indicates that CPU and sensor board require continuous energy supplies. The life span of sensor directly influences the life of the whole wireless sensor network. To calculate the life span of a sensor, we have to figure

TABLE 1: Packet per energy value.

Parameters	Value
$E_{TX}$ (data transmission energy)	$5 \times 10^{-8}$ J/bite/m <sup>2</sup>
$E_{RX}$ (data receiving energy)	$5 \times 10^{-8}$ J/bite/m <sup>2</sup>
$E_{RXClusterHead}$ (data receiving energy cluster head)	$5 \times 10^{-8}$ J/bite/m <sup>2</sup>
$\epsilon_{amp}$ amplifier energy	$1.3 \times 10^{-15}$ J/bits/m <sup>2</sup>
$\epsilon_f$ energy of fusion	$10^{-11}$ J/bits/m <sup>2</sup>
$E_{DA}$ (data aggregation energy)	$5 \times 10^{-9}$ J
Packet header size	20 bits
$K_{bite}$ packet size	2048 bits (2 KB)

TABLE 2: Cluster network assumption.

S. no	Parameters	Values
1	Number of normal node in the cluster	6
2	Cluster head node	1
3	Field size nodes are deployed	50 m $\times$ 50 m
4	Average distance between CH and ordinary node	100 m

TABLE 3: Idle state sensor energy dissipation and active sensor current consumption.

(a)

Hardware	$V$ in V	$I$ in A	$t$ in sec	$E$ in J
Idle CPU	1.45	0.0032	0.00042	1.9968E-06
Power down	1.45	0.000103	0.00042	6.4272E-08
Power save	1.45	0.00011	0.00042	6.864E-08
Standby	1.45	0.000216	0.00042	1.34784E-07
Total energy				2.26E-06

(b)

Sensor hardware	$I$ in A
Active CPU	0.008
ADCs	0.001
Oscillator	0.00093
LED	0.0022
Sensor board	0.0007
Extended stand by	0.00022
Total current	0.01305

out all energy consumed during the real time operation. The total energy consumed during the real time operation is represented by “Ece.”

$$E_{ce} = E_a + E_i, \quad (1)$$

where “Ea” is the energy consumed in active state and “Ei” is energy consumed in idle state. “Eb” stands for the energy stored in a battery that is to be utilized by the sensor. The life span or availability of a sensor network directly depends on the energy stored in a battery.

After a constant and precise analysis of a sensor’s packet transmission and energy dissipation, it sends 2068000 bits or 2019.531 KB of data to the cluster head within 50 days. Due to shortage of energy, a sensor will be unable to send data to the cluster head after 1000 rounds of operation as represented in Figure 9.

**8.5. Cluster Head (CH) Node Energy Consumption in State of Active.** The feasibility of an ordinary sensor is directly influenced by left over energy of cluster head. If the cluster head (CH) node encounters the shortage of energy in the cluster, the ordinary nodes in the cluster are supposed to send

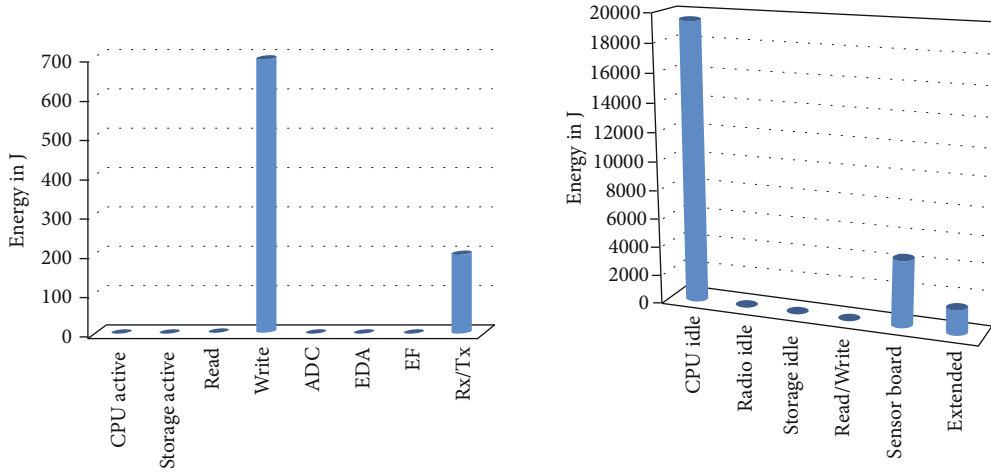

FIGURE 7: Energy consumption of sensor node in state of active and idle.

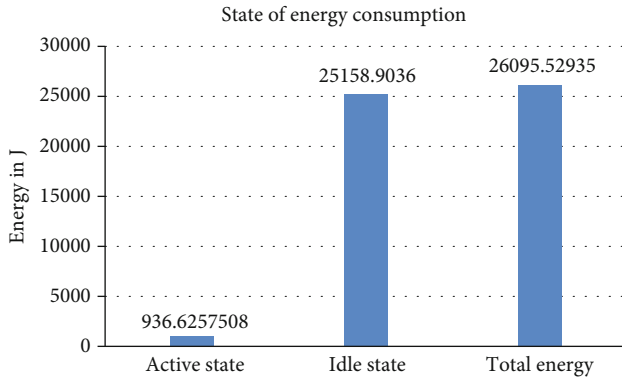

FIGURE 8: Energy consumption of idle and active state.

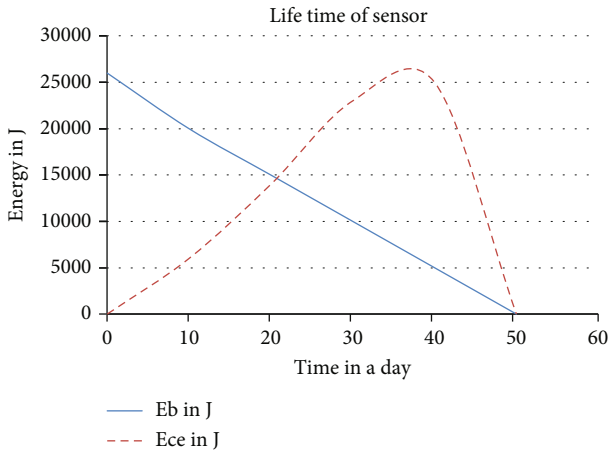

FIGURE 9: Life time vs. energy consumption.

packet. The experimental analysis clearly shows that the cluster head node is not long lasting in a cluster. It is suffering continuously by receiving, aggregating, and sending packets to the base station (BS). The energy dissipation of a cluster head (CH) with six ordinary nodes in a cluster is calculated below,

$$E_{CH} = E_{Rx} + E_{DA} + E_{Tx\ send}, \quad (2)$$

$$E_{CH} = E_{Rx}KN + E_{RxCH}K + E_{DA} + E_{Tx\ send},$$

where  $E_{sd}$  represents energy required by sensor to send a single packet to the cluster head,  $E_{CH}$  represents the cluster head energy which receives packet from a sensor,  $E_{DA}$  represents the energy required by cluster head for data aggregation before it sends to base station, and  $E_o$  is an initial total energy of sensor node.  $K$  and  $N$  stands for packet size and numbers of node in the cluster, respectively.

The experimental result in Figure 10 emphasizes that after a time elapse of 16.6667 days of operation, the cluster head node is unable to receive a packet from sensor node and send it to base station due to shortage of energy. “ $E_c$ ” and “ $E_b$ ” represents energy consumed by cluster head and energy stored in a battery, respectively. The life of a CH sensor is directly proportional to its battery life.

If there is no  $E_c$  (consumed energy), then a battery is unable to supply energy to cluster head node. This situation stops the whole network life. The experimental results reveal that the ordinary node in the cluster has a longer life span or has a higher life expectancy than the cluster node.

The next algorithm proposed is to discharge batteries. During cloudy day and night time, the load (sensor) gets energy from battery since in the newly model two batteries for ordinary and three batteries for cluster head (CH) are designed; it also needs an alternative discharging algorithm. Before the load discharges the energy, the microcontroller checks the battery status. The working principles of the discharging algorithm are as follows.

If no sun or night time

- (1) Load  $\rightarrow$  discharge Bt1, if Bt1 = 2.75 V then
- (2) Load  $\rightarrow$  discharge Bt2, if Bt2 = 2.75 V then
- (3) Load  $\rightarrow$  discharge Bt3, if Bt3 = 2.75 V then go to step 1 else
- (4) Go to step sunny day principle

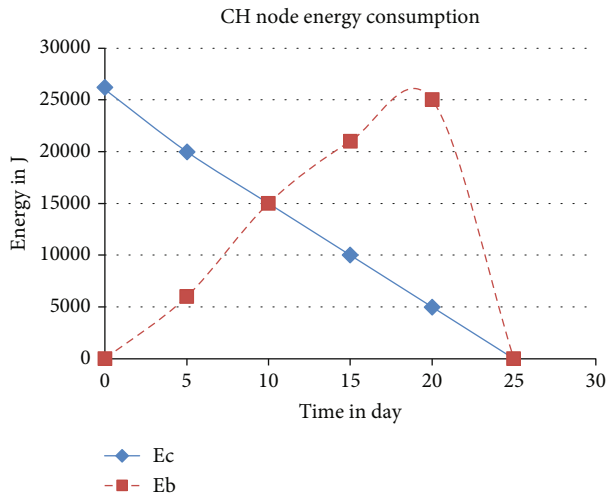

FIGURE 10: Cluster head node energy dissipation.

**8.6. Solar-Powered Sensor Node Experimental Result and Discussion.** The theorization in the newly proposed model is that if there is no sun light (cloudy day) for about 60 days, then how many day the node will sustain in the network is a critical question. A node in cluster having a battery and photovoltaic panel for harvesting solar energy from the sun sustains only for about 50 days. The newly proposed model continuously working for more than 50 days and prolonged life span or availability of the whole network is shown in Figure 11.

The sensor will stop working after 50 days because of shortage in energy supply. For next 10 days, there will be more operations. The sensors will be unable to send and receive a packet from the surrounding or nearby node which is represented in Figure 12.

**8.7. Solar-Powered Cluster Head Experimental Result and Discussion.** The CH sensor receives data from the first level node in the cluster. The CH also aggregates the data and sends it to base station (BS). During this operational activity, the cluster head nodes dissipate more energy and sustain in the network for about 16.6667 days according to the earlier analysis.

The researchers thoroughly gather data for how much time elapse is taken by the battery to fully charge and discharge. The life of a cluster head node in the network is not more than 16.6667 days according to the earlier analysis above. There are six ordinary sensor nodes in a cluster network and periodically report data to the cluster head (CH) node after 30 minutes. According to the analysis, more energy is dissipated or depilated from the cluster head node. The newly proposed cluster head (CH) node has group of three batteries which are fully charged at the beginning.

Figure 13 represents a cluster head with a single rechargeable battery, and solar energy harvester is experimentally tested after 30 days of no sun light (cloudy day). After 16.6667 days, the energy gets depilated, and the cluster head stops its operation. The cluster head stays idle without power for about 10 days. But, after 30th day, the solar panel

starts to charge the battery and supplies energy to the load (cluster head node).

A cluster head with a pair of rechargeable battery and solar energy harvester is experimentally tested after 30 days of no sun light (cloudy day). After 30 days, the solar panel starts to charge the first battery then alternatively charges the next battery. The newly proposed algorithm controls the sequence of charging and discharging as shown in Figure 14.

The newly proposed algorithm charges a single battery at a time. The harvested solar energy is directly supplied to load and charges the battery at the same time. The most sustainable and energy efficient model which is proposed by the researchers is the cluster node with a group of three batteries. It supplies an energy for about 56.25 days without solar energy supplement. The newly proposed algorithm charges and discharges the three batteries alternatively. Since there is no sun light for time being, the algorithm now discharges the three batteries alternatively. Technically, a battery cannot be charged and discharged at the same time. It is impossible to do that because this may cause a technical failure and explosion to the battery.

If the sun light is available, the discharged batteries are charged alternatively. The microcontroller checks the battery status before charging it by using the newly proposed algorithm. The critical threshold values of a battery voltage are checked continuously.  $V_{\max} = 4.2\text{ V}$  and  $V_{\min} = 2.75\text{ V}$  are the maximum and minimum threshold value of a battery. Generally, the experimental result indicates that the life span of an ordinary sensor is increased from 50 to 91.66667 days and that of cluster head node is increased from 16.6667 to 54.16667 days. The node utilizes (discharge) the supplied battery alternatively. Hence, the depleted battery is ready for the next charging through solar. The newly developed algorithm plays a crucial role in charging and discharging the batteries.

**8.8. Simulation Results and Discussion.** The open source electric circuit simulator software is used to design, analyze, and test a circuit virtually on a computer. There are different simulator softwares online and which directly work on the website. Circuit sims, DCACLab, EveryCircuit, DoCircuits, Proteus professional, Arduino IDE, and many more are electric circuit simulator software.

**8.9. Software Tools Used.** The researchers have used the Arduino IDE and Proteus professional software. The Proteus professional software is a mixed mode and SPICE-based electronic circuit simulation tool from Lab center. It runs on all window operating system. It has two versions called basic and advanced. Basic version is free and supports interactive simulation only while advanced supports a range of useful functions and futures like graph-based analysis which includes frequency, noise, and distortion parameters. The newly proposed model and algorithm are simulated by Proteus 8 professional and Arduino IDE. The Proteus 8 professional application software and Arduino IDE are used for writing and compiling the code into the Arduino Module.

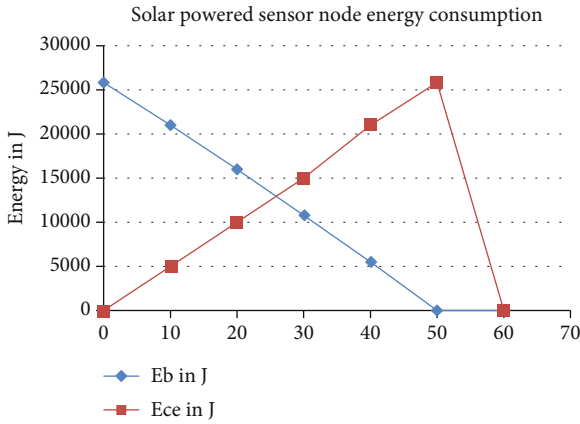

FIGURE 11: Solar-powered sensor node energy consumption.

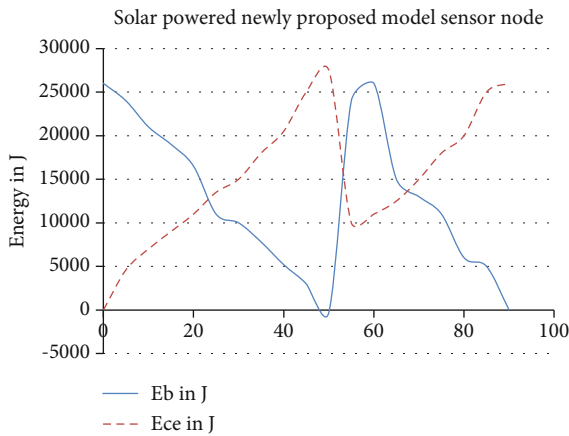

FIGURE 12: Solar-powered newly proposed sensor node.

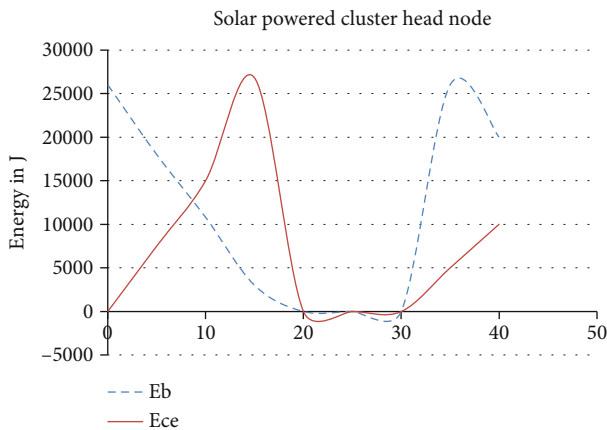

FIGURE 13: Solar-powered cluster head node.

8.10. *Proteus 8 Professional Application Software.* In this technological world before an electrical installation is implemented, it has to be designed and simulated to test its utility by the Proteus 8 professional application software. The software has all electrical components with valued resistance, current, power, and energy. The Proteus 8 professional is

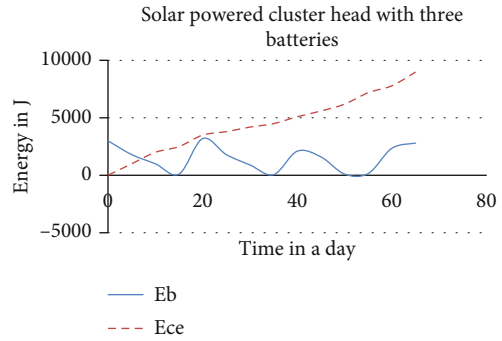

FIGURE 14: Solar-powered cluster head node with three batteries.

used to design the model components and the principal work flow. The model is designed for both sensor and cluster head node. The cluster head node model contains PV solar panel as energy harvester, MUC, three (AAA sized batteries), and the sensor as a load. The ordinary sensor node model also contains PV solar panel as energy harvester, MUC, three (AA sized batteries), and the sensor as a load.

The microcontroller checks the status of a battery before initiating charging pins. If the first battery’s voltages are reached to the minimum threshold 2.75 V, then pin1 becomes initiated to be “ON” and starts charging Bt1 (battery 1). After Bt1 voltage reaches to maximum threshold 4.2 V, pin1 becomes “OFF” and terminates charging.

The second battery Bt2 is initiated to charge only after the Bt1 is charged and when reached to the maximum threshold value. Alternatively, charging and continuity are controlled by microcontroller which is enhanced by the newly proposed algorithm.

The last battery Bt3 is charged once the Bt2 is fully charged. If all batteries are fully charged, the charging process is terminated by the microcontroller. But, if there is a dissipation of energy from the Bt1, the Bt2 is to be discharged. If the Bt2 is discharged and reaches the minimum threshold, then Bt3 is ready to be discharged. Meanwhile, if there is sun light, the microcontroller initiates Bt1 to charge which is already discharged.

The researchers used Arduino IDE to code and prolog the algorithms and the Proteus professional software to designing a model and simulate its functionality. The results of the principal functions of the proposed model during the simulation are presented as follows.

8.10.1. *Battery 1 Charging.* In Figure 15, microcontroller checks the status of all batteries before it starts charging. If voltage of battery 1 is of minimum threshold 2.75 V, then pin1 becomes “ON” and starts charging. If the battery’s voltage is reached to maximum threshold 4.2 V, then pin1 becomes “OFF” and terminate charging.

8.10.2. *Battery 2 Charging.* In Figure 16, the microcontroller checks the status of battery 2 before it starts charging. If voltage of battery 2 is of minimum threshold 2.75 V, then pin2 becomes “ON” and starts charging. If the battery’s voltage reaches to maximum threshold of 4.2 V, then pin2 becomes “OFF” and terminates charging.

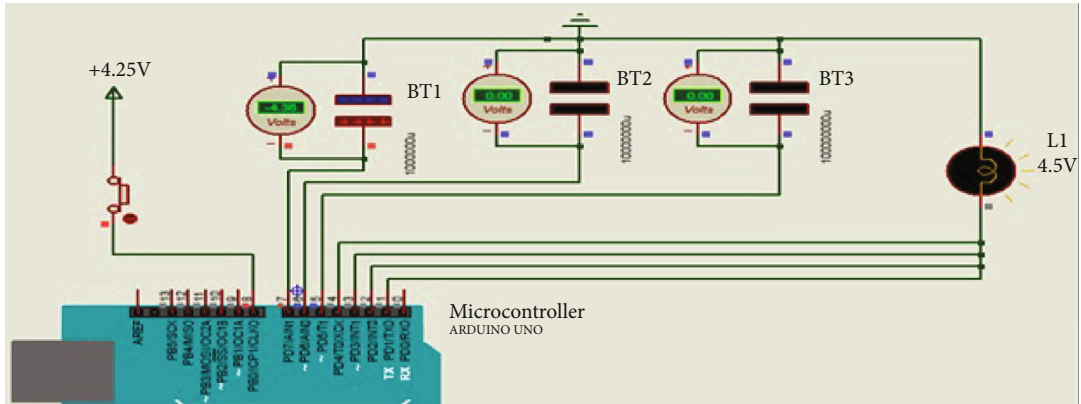

FIGURE 15: Battery 1 charging simulation.

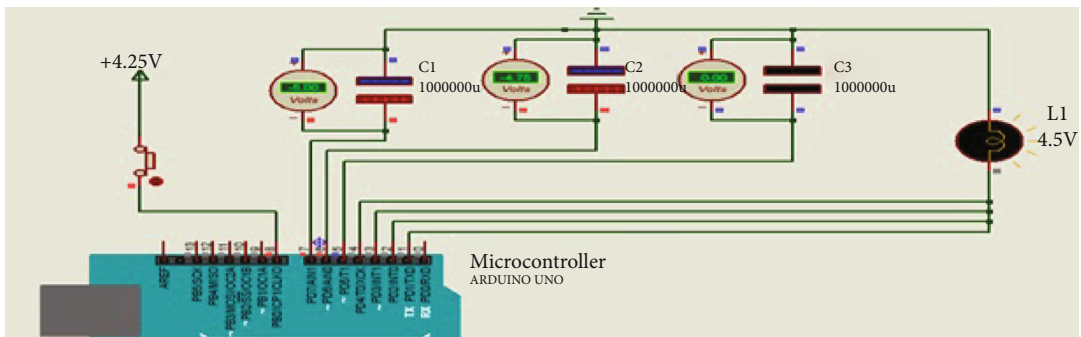

FIGURE 16: Battery 2 charging simulation.

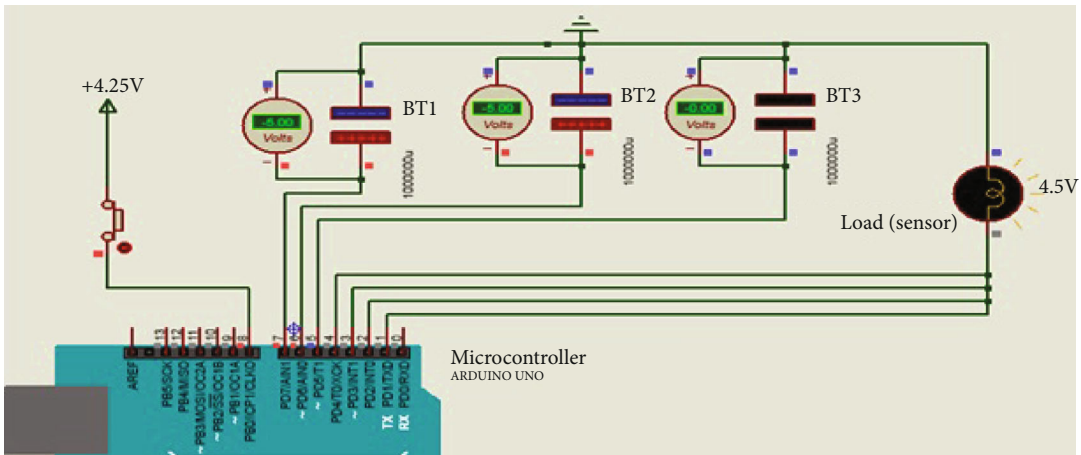

FIGURE 17: Battery 3 charging simulation.

8.10.3. *Battery 3 Charging.* In Figure 17, the microcontroller checks the status of battery 3 before it starts charging. If voltage of battery 3 is of minimum threshold with 2.75 V, then pin3 becomes “ON” and starts charging. If the battery’s voltage is of maximum threshold with 4.2 V, then pin3 becomes “OFF” and terminates charging.

## 9. Conclusion

Wireless sensor node is one of the most important parts in the whole of WSN, spasmodically composed of low-energy sensor equipment, surrounded with microcontroller and Wi-Fi transceiver. Embedded microcontrollers are typically

used to gather data and methodize the extracted statistics from sensors. The features of a sensor produce a measurable reaction to modify internal parts of it (which include temperature, humidity, pressure, and humidity). The Wi-Fi transceiver transmits the statistics extracted from the sensors to the base station or via the mutual verbal exchange among the nodes. Sensor nodes are deployed in both accessible and inaccessible range as they are powered from batteries. Since the energy provided to the batteries is limited, the lifetime of the sensors is shortened. Manually replacing the sensor's battery is due to the location constraints in sensor nodes deployment. The shortage of energy causes a major drawback on the performance and lifetime of WSNs. The researchers thoroughly identify the challenges, limitations, and drawbacks of sensor node's energy sources. The primary source of the sensor node obtains energy from both chargeable and nonrechargeable batteries. As a secondary source, the sensor node acquires the energy from solar, wind, piezoelectric, radio frequency, vibration, and heat. The energy of all these sources has their own limitations and challenges. The researchers identified solar energy as a very good source of energy relatively the other in terms of availability, predictability, and sustainability for both fixed and random deployments of sensor node. Photovoltaic (PV) solar panel is used for energy harvesting, and it delivers to both load and charge batteries simultaneously. The researchers also recognize Li-ion polymer as highly efficient rechargeable battery in terms of overcharge tolerance, self-discharge/month, and maintenance requirement. In this research, the researchers have developed a model and an algorithm that guarantees the energy sustainability for a sensor node through harvesting solar energy with Li-ion polymer rechargeable battery, which more specifically increases the life span of sensor and the whole WSNs. After the researchers' experimental testing, the life spans of both conventional and cluster head (CH) sensors are significantly extended. In the worst-case scenario (lack of sunlight or excessive cloudiness), the testing results showed that the life span of an ordinary sensor node has increased. Previously in other research articles, it was specified that the lifetime is only 50 days for an ordinary sensor node, but after experimental analysis, it is extended to 91.66667 days. Similarly, the cluster head node has also upgraded 16.6667 to 54.16667 days.

## 10. Contribution of the Study

The annexations of this research are as follows: (1) solar energy harvesting system which is enhanced by the developed photovoltaic cell sensor node model. The model is designed with both cluster head (CH) node and ordinary node in the cluster. The cluster node is designed with a group of three rechargeable Li-ion polymer batteries, and the ordinary node is designed with a two rechargeable Li-ion polymer batteries. The consumption of energy by ordinary sensor and cluster head (CH) node is different due to their job assessments. (2) The proposed algorithm controls the energy harvested from the solar panel which is used to control the energy supply of both Li-ion polymer rechargeable batteries and a load (sensor). The microcontroller is

enhanced by the algorithm to check the battery status whether it is ready to charge or discharge. It also controls the charging system of the batteries by checking their status and charging them alternatively. (3) The life spans of both ordinary and cluster head (CH) sensor are prolonged in a significant way after the experimentally test of the researchers. In the worst case (absence of sunlight or too much cloudy) of the analysis, the experimental result indicated that the life span of ordinary sensor node is increased from 50 to 91.66667 days and that of cluster head node is increased from 16.6667 to 54.16667 days.

## Abbreviations

ADC:	Analog to digital convertor
Ah:	Ampere hour
BS:	Base station
Bt1:	Battery 1
Bt2:	Battery 2
Bt3:	Battery 3
C:	Capacitance
CH:	Cluster head
CH-WSN:	Clustered heterogeneous wireless sensor networks
DAC:	Digital to analog convertor
DC-DC:	Direct current-direct current
DDEEC:	Developed distributed energy efficient clustering
DEEC:	Distributed energy efficient clustering
EDEEC:	Enhanced distributed energy efficient clustering
EDLC:	Electric double layer capacitor
EESEP:	Energy efficient stable election protocol
EH:	Energy harvest
$E_o$ :	Initial energy
$E_{RX}$ :	Energy of packet receive
$E_{TX}$ :	Energy of packet send
HEED:	Hybrid energy efficient distributed clustering
IDE:	Integrated development environment
ISM:	International system for mobile
$L$ :	Life
LCA:	Linked cluster algorithm
LCA2:	Linked cluster algorithm 2
LEACH:	Low-energy adapting clustering hierarchy
LEDs:	Light emitted diodes
MCU:	Microcontroller unit
MPPT:	Maximum power point tracker
PV:	Photovoltaic
RF:	Radio frequency
SHE:	Solar energy harvesting
SuperCap:	Supper capacitor
TDEEC:	Threshold distributed energy efficient clustering
WSNs:	Wireless sensor networks.

## Data Availability

On reasonable request, the corresponding author will provide the datasets used and/or analyzed during the current study.



## Disclosure

To succor the Community of Ethiopia, the researchers quarterback this study as part of their Research Oriented Progress.

## Conflicts of Interest

The authors declare that they have no conflicts of interest.

## References

- [1] M. S. Manshahia, "Wireless sensor networks: a survey," *International Journal of Scientific & Engineering Research*, vol. 7, no. 4, pp. 712-713, 2016.
- [2] B. I. Sutapa Sarkar, "Energy harvesting method in wireless sensor network," *International Journal of Education (IJE)*, vol. 1, no. 1, pp. 63-70, 2013.
- [3] A. Y. Amita Singh, "A comprehensive study and review on wireless sensor networks, based on heterogeneous energy distribution & multizone algorithm," *International Journal of Advanced Research in Computer and Communication Engineering*, vol. 5, no. 4, pp. 1111-1112, 2016.
- [4] B. S. Ashish Gupta, "Power management in wireless sensor networks," *International Journal Of Advanced Research*, vol. 5, no. 1, pp. 163-165, 2014.
- [5] C. Divya, N. Krishnan, and T. Gandhi, "Energy efficient stable election protocol for clustered heterogeneous wireless sensor networks," *IOSR Journal of Computer Engineering*, vol. 12, no. 5, pp. 55-61, 2013.
- [6] S. C. Jacopo Olivo, *Energy harvesting and remote powering*, IEEE, 2011.
- [7] H. Sharma, A. Haque, and Z. Jaffery, "Modeling and optimisation of a solar energy harvesting system for wireless sensor network nodes," *Journal of Sensor and Actuator Networks*, vol. 7, no. 3, p. 40, 2018.
- [8] S. O. Olatinwo and T.-H. Joubert, "Energy efficiency maximization in a wireless powered IOT sensor network for water quality monitoring," *Computer Networks*, vol. 176, article 107237, 2020.
- [9] R. Fotohi and S. Firoozi Bari, "A novel countermeasure technique to protect WSN against denial-of-sleep attacks using firefly and Hopfield neural network (HNN) algorithms," *The Journal of Supercomputing*, vol. 76, no. 9, pp. 6860-6886, 2020.
- [10] H. Pakdel and R. Fotohi, "A firefly algorithm for power management in wireless sensor networks (wsns)," *The Journal of Supercomputing*, vol. 77, no. 9, pp. 9411-9432, 2021.
- [11] H. Mohapatra, "An efficient energy saving scheme through sorting technique for wireless sensor network," *International Journal of Emerging Trends in Engineering Research*, vol. 8, no. 8, pp. 4278-4286, 2020.
- [12] M. M. V. M. Kumar and A. Chaparala, "A hybrid BFO-FOA-based energy efficient cluster head selection in energy harvesting wireless sensor network," *International Journal of Communication Networks and Distributed Systems*, vol. 25, no. 2, p. 205, 2020.
- [13] S. O. Olatinwo and T. H. Joubert, "Efficient energy resource utilization in a wireless sensor system for monitoring water quality," *EURASIP Journal on Wireless Communications and Networking*, vol. 2019, no. 1, 2019.
- [14] S. Olatinwo and T.-H. Joubert, "Optimizing the energy and throughput of a water-quality monitoring system," *Sensors*, vol. 18, no. 4, p. 1198, 2018.
- [15] M. Zekiwo and A. Bruck, "Deep learning-based image processing for cotton leaf disease and pest diagnosis," *Journal of Electrical and Computer Engineering*, vol. 2021, Article ID 9981437, 10 pages, 2021.
- [16] G. Nemomsa and M. Azath, "Designing a predictive model for antiretroviral regimen at the antiretroviral therapy center in Chiro Hospital, Ethiopia," *Journal of Healthcare Engineering*, vol. 2021, Article ID 1161923, 10 pages, 2021.