

## *Retraction*

# **Retracted: Computer Multimedia-Oriented Chinese Language and Literature Distance Teaching System**

### **Wireless Communications and Mobile Computing**

Received 19 September 2023; Accepted 19 September 2023; Published 20 September 2023

Copyright © 2023 Wireless Communications and Mobile Computing. This is an open access article distributed under the Creative Commons Attribution License, which permits unrestricted use, distribution, and reproduction in any medium, provided the original work is properly cited.

This article has been retracted by Hindawi following an investigation undertaken by the publisher [1]. This investigation has uncovered evidence of one or more of the following indicators of systematic manipulation of the publication process:

- (1) Discrepancies in scope
- (2) Discrepancies in the description of the research reported
- (3) Discrepancies between the availability of data and the research described
- (4) Inappropriate citations
- (5) Incoherent, meaningless and/or irrelevant content included in the article
- (6) Peer-review manipulation

The presence of these indicators undermines our confidence in the integrity of the article's content and we cannot, therefore, vouch for its reliability. Please note that this notice is intended solely to alert readers that the content of this article is unreliable. We have not investigated whether authors were aware of or involved in the systematic manipulation of the publication process.

Wiley and Hindawi regrets that the usual quality checks did not identify these issues before publication and have since put additional measures in place to safeguard research integrity.

We wish to credit our own Research Integrity and Research Publishing teams and anonymous and named external researchers and research integrity experts for contributing to this investigation.

The corresponding author, as the representative of all authors, has been given the opportunity to register their agreement or disagreement to this retraction. We have kept a record of any response received.

### **References**

- [1] H. Zhang, "Computer Multimedia-Oriented Chinese Language and Literature Distance Teaching System," *Wireless Communications and Mobile Computing*, vol. 2022, Article ID 8231585, 8 pages, 2022.

## Research Article

# Computer Multimedia-Oriented Chinese Language and Literature Distance Teaching System

Hongshun Zhang 

Basic Teaching Department, Huanghe Jiaotong University, Jiaozuo 454950, China

Correspondence should be addressed to Hongshun Zhang; 19401014@masu.edu.cn

Received 4 July 2022; Revised 28 July 2022; Accepted 25 August 2022; Published 5 September 2022

Academic Editor: Hamurabi Gamboa Rosales

Copyright © 2022 Hongshun Zhang. This is an open access article distributed under the Creative Commons Attribution License, which permits unrestricted use, distribution, and reproduction in any medium, provided the original work is properly cited.

The traditional Chinese language and literature distance teaching system has the problem of incomplete instruction recognition function, which leads to the slow connection speed of the system. This paper designs a computer multimedia Chinese language and literature distance teaching system. For the hardware part, strain gauge and sensor are combined, connected to VCC through 10 K ohm pull-up resistance, and connected to other components. The software part obtains the expression form of Chinese language and literature; formulates the training target, according to the antimonotone characteristics of the support degree; adopts the association rule algorithm to build the remote teaching system database, combined with the client to parse the signaling message; and designs the software instruction recognition function by using the computer multimedia technology. *Experimental Results.* The average connection speeds of the Chinese language and literature distance teaching system in this paper and the other two kinds of Chinese language and literature distance teaching system are 8.737 s, 13.140 s, and 13.156 s, respectively, which proves that the performance of the Chinese language and literature distance teaching system combined with computer multimedia technology is more perfect.

## 1. Introduction

Traditional education is passive mode led by teachers, and students' learning initiative is poor. With the development of real-time communication technology, especially the rapid development of WebRTC technology, this one-way education mode will be gradually broken, so that students can learn knowledge from anyone at anytime and anywhere. Due to the rapid increase of social demand for education, the traditional education model can no longer fully meet this need, and online distance education is bound to become a very important way of knowledge dissemination [1, 2]. Computer multimedia technology is playing an increasingly obvious role in the field of teaching, especially in web-based open distance teaching [3]. Web-based open distance teaching system is a new teaching form developed on the basis of modern information technology such as computer network technology and multimedia video exchange technology [4, 5]. This can make up for the regional imbalance in education to some extent, so that children in remote areas can also receive quality education. The most important part of the

distance education system is the push of streaming media. At present, many live streaming platforms, no matter education or game, mainly use the technology of RTMP protocol to transmit video streams. In the network distance education system, a core part is the production of teaching content. At present, most of the courseware provided by the network distance education system are web pages written with HTML language. However, the main problem is that RTMP is based on TCP. Due to TCP three-way handshake, flow control, congestion control, and other mechanisms, the delay is relatively high. However, real-time audio and video are sensitive to delay, and it is based on TCP, so it cannot control audio and video data flexibly. Moreover, there are many disadvantages such as production trouble and synchronization difficulty. Therefore, it needs a courseware form with better demonstration effect, a tool for making courseware with simple operation and powerful function, and a shared teaching resource library facing Internet. But WebRTC technology is different; this technology uses UDP-based RTP protocol to transmit real-time media stream; the delay is low and can control the audio and video

data according to the demand, in order to realize that the distance education system education resources and education methods are not constrained by time and space. With the rapid development of network technology and the acceleration of teaching technology reform, the education of colleges and universities in China is developing towards network and informatization, so as to break through the limitations of school geographical location and achieve teaching effects such as distance teaching, so as to realize the sharing of teaching resources in the whole country [6–8]. At present, the research data about the distance teaching system of Chinese language and literature need to be further improved.

However, when utilized in a classroom or for educational purposes, multimedia applications' design quality and sophistication must be high enough to mix the various cognitive processes in order to accomplish the finest teacher mimicry. Multimedia apps come in a variety of forms and are currently accessible on the market. These programs have been used for a variety of educational reasons, including works for math classrooms, social science classes, science classes, physiology lessons, physics classes, and physical education studies [9].

## 2. Hardware Design of Chinese Language and Literature Distance Teaching System for Computer Multimedia

In the remote teaching system, in order to realize the real-time video streaming transmission effect, the video conference mode is adopted, and the video conference terminal is ZXMVC8900. ZXMVC8900 is a fully compatible intelligent video server designed and manufactured by ZTE with carrier-grade modular architecture. The equipment can fully support ITU-T H.323, H.320, and SIP protocols and access user terminals through IP, SDH, ATM, and other different networks, so as to achieve the 720p and 1080p resolutions of video and broadband voice processing. Common sensors are mainly analog sensors, digital sensors, and switching sensors, which are classified according to the output signal of the sensor. The specific block diagram of sensor composition is shown in Figure 1.

As can be seen from Figure 1, the sensitive element is the part that directly feels or responds to be measured and is converted into the part that has definite corresponding relationship with the measured according to certain rules. It is the function of analog sensor to convert measured nonelectrical quantity into analog electric signal and digital signal to convert measured nonelectrical quantity into digital output signal. The input and output data of the switch sensor are 0 or 1, so they can be installed in any sensor interface of the controller. The user wants to make the robot achieve a certain function; he uses the corresponding sensor. Programming switch sensor control is also directly high and low level control, switch sensor use and control is simple, and the price is also very cheap. ZXMVC8900 uses a variety of advanced technologies to support video streaming up to 8M bandwidth and achieve 1080p image resolution under this condition. By referring to the relevant sensor datasheet,

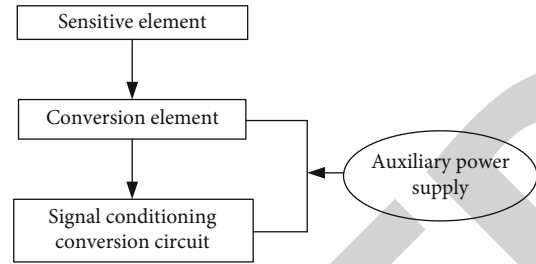

FIGURE 1: Block diagram of sensor composition.

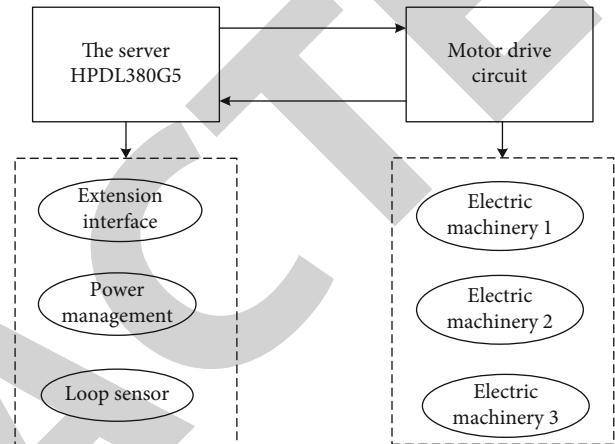

FIGURE 2: Server and motor drive circuit architecture diagram.

it can be seen that the temperature and humidity sensor is a single bus communication, data receiving, and receiving by a line; US 100 uses serial communication, GY30 uses IIC communication, HX711 uses SPI communication, serial communication interface has been reserved, and the sensor can be used according to the port plug. The architecture of server and motor drive circuit is shown in Figure 2.

As can be seen from Figure 2, the main chip of the controller runs the main program of the system, and all control commands are conveyed to sensors and drivers by it, which then complete the specified functions. HX711 chip is a 24-bit A/D conversion chip. The module is specially applied in the design of high-precision electronic balance. The combination of the module and strain gauge can be assembled into a weighing sensor. In the design process of distance education system, the server involved in system application uses HPDL380G5, which has the highest cost performance among servers with the same configuration. LS5328 gigabit switch manufactured by Huawei is used in the system design process, which is suitable for medium network applications. The dark part is HX711 chip, and the sensor is a sensor with strain gauge. The module communicates with MCU chip through two pins of DOUT and PD SCK. STM32F 103 VET6 chip is an enhanced CHIP in STM32 chip, which has a variety of common peripherals on the chip, convenient connection with sensors and motors, with excellent control characteristics. S TM32F 103 VET6 is a 32-bit ARM chip based on the Cortex-M3 kernel, which uses the Harf structure. The chip is integrated with a separate instruction and data bus. The software programming of the processor is

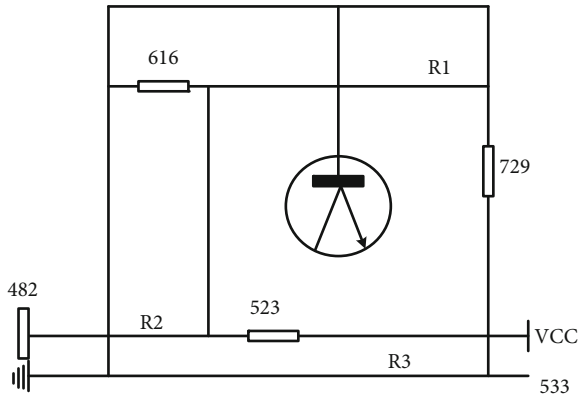

FIGURE 3: Sensor circuit design diagram.

written in C language, which is convenient for users to develop efficient control programs. The sensor circuit design is shown in Figure 3.

As can be seen from Figure 3, the working principle is to control the voltage of the output signal (R1 pin of the sensor interface) by using the characteristics of the photosensitive two-stage tube. The R2 pin of the sensor interface is connected to the power supply, and the R3 pin is grounded. The output of the signal line is low level. When the reflected light on the ground surface is dark, the photodiode 523 ends, and the signal line output is high level. NAND FLASH uses complex I/O port to access data serialized, address line, and data line multiplexing, operation is “page” as the basic unit, the size of the page is generally 512 bytes, writing speed is very fast, NAND FLASH has higher unit density, and capacity can be relatively large, mainly in 8~128 MB. Random access memory (RAM) is a volatile memory. After power failure, data disappears and cannot be preserved for a long time. A reset circuit is a circuit used to restore a circuit to its initial state by pushing a button. MT45W4ML16FPA chip is also a 16-bit data bus. The connection method is similar to NOR FLASH, except that nCSO of LPC2290 is connected to the/CE end of MT45W4ML16FPA chip. BLSO and BLSI pins are connected to UB and LB terminals of MT45W4ML16FPA chip, respectively. Since the reset pin of the STM32 chip is effective at low level, the reset circuit is connected to the VCC by a pull-up resistor of 10 K ohms in normal state and keeps the pin at high level. When the button is pressed, the reset pin connected to GND is pulled down by the electric flat, and the chip is reset. In addition, C15 high frequency filter capacitor is added to the circuit. Based on this, complete the steps of hardware design of Chinese language and literature distance teaching system.

### 3. Software Design of Chinese Language and Literature Distance Teaching System for Computer Multimedia

*3.1. Acquiring Chinese Language and Literature Expression Forms.* Chinese language and literature is an undergraduate major of literature set up by universities in China. Its training goal is to cultivate senior specialized talents of Chinese

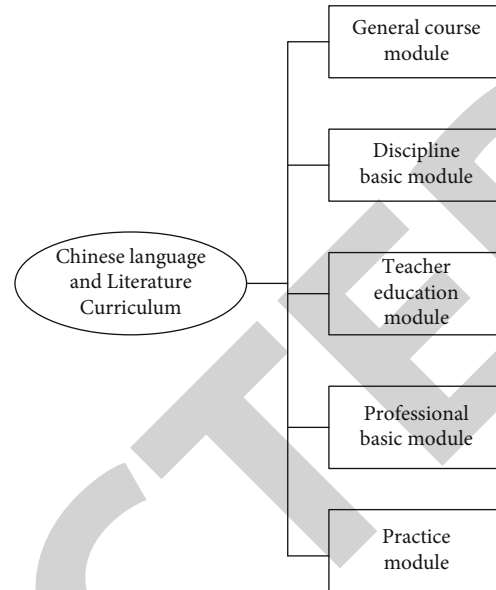

FIGURE 4: Curriculum structure of Chinese language and literature.

language and literature who can engage in literary criticism, teaching, and research of Chinese language and literature, culture, and propaganda in press and publication departments, universities, scientific research institutions, and government enterprises and public institutions. The educational curriculum setting of the distance teaching system is the core of the teaching plan and the embodiment of the training objectives of normal education [10, 11]. And “professional education” in Chinese literature is the direction of normal education in Chinese language and literature major, so also known as the “Chinese language and literature (normal)” or “Chinese language and literature (normal education direction)”; the training goal is to cultivate qualified for the middle school language teaching and research of teachers, teaching research and teaching management personnel, and other education workers. It can reflect the specific specifications of future teachers. The establishment of training objectives has a direct impact on the curriculum setting. In order to develop a teacher education curriculum conducive to the professional development of music teachers, the content of teacher professional development should be reflected in the training objectives first. The curriculum of Chinese language and literature is divided into five modules, as shown in Figure 4.

As can be seen from Figure 4, for the Chinese language and literature teacher training major, the professional training objectives formulated by colleges and universities reflect the content of the professional development of Chinese teachers. The students majoring in Chinese Language and literature should combine their specialty with the nature of normal education and become the real nature of normal education. The ratio of class hours and credits to educational courses and teaching practices of normal university students is relatively low, leading to the weakening of teachers’ ability. The curriculum of Chinese language and literature should adopt the “platform + module” curriculum mode. Most of

TABLE 1: Number of users of 50 connection speed (s).

| Number of experiments | Distance teaching system of Chinese language and literature based on leapfrog algorithm | Chinese language and literature distance teaching system based on genetic algorithm | Chinese language and literature distance teaching system in this paper |
|-----------------------|---|---|--|
| 1                     | 4.365   | 3.558   | 2.110  |
| 2                     | 3.998   | 4.226   | 1.996  |
| 3                     | 4.106   | 3.916   | 2.034  |
| 4                     | 3.847   | 4.253   | 1.887  |
| 5                     | 4.223   | 3.886   | 2.229  |

TABLE 2: Number of users of 100 connection speed (s).

| Number of experiments | Distance teaching system of Chinese language and literature based on leapfrog algorithm | Chinese language and literature distance teaching system based on genetic algorithm | Chinese language and literature distance teaching system in this paper |
|-----------------------|---|---|--|
| 1                     | 8.915   | 9.114   | 3.595  |
| 2                     | 9.054   | 8.553   | 3.612  |
| 3                     | 8.332   | 9.201   | 2.998  |
| 4                     | 9.067   | 8.771   | 3.115  |
| 5                     | 8.228   | 8.546   | 2.773  |

them adopt instillation teaching method, ignoring students' active participation and inquiry. As a result, the quality of students has not been fully developed actively. Based on this, the new curriculum reform emphasizes on a balanced and reasonable arrangement of courses with different functions and values and reflects comprehensiveness and selectivity, which should meet the needs of students' physical and mental development and the requirements of the future society for talent quality. Based on the above description, complete the steps of obtaining the expression form of Chinese language and literature.

**3.2. Construction of Distance Teaching System Database by Association Rule Algorithm.** Association refers to the rule characteristics between two or more data variables. Simply classify the correlation, including basic correlation, causal correlation, and temporal correlation. Association rules are the key technology in data mining. Its common algorithms include FP-tree frequency set algorithm, Apriori algorithm, partition-based algorithm, and so on. Generally, two measurement standards are adopted: one is the use frequency or support (such as frequent itemset mining), and the other is the efficiency value or profit as the main measurement standard. Assuming that the root node is the extension length, according to the anti-monotonicity of support, it

TABLE 3: Number of users of 300 connection speed (s).

| Number of experiments | Distance teaching system of Chinese language and literature based on leapfrog algorithm | Chinese language and literature distance teaching system based on genetic algorithm | Chinese language and literature distance teaching system in this paper |
|-----------------------|---|---|--|
| 1                     | 15.626  | 15.686  | 11.221   |
| 2                     | 13.007  | 14.551  | 13.465   |
| 3                     | 15.649  | 13.009  | 13.911   |
| 4                     | 13.461  | 14.220  | 14.388   |
| 5                     | 14.008  | 13.964  | 12.556   |

can be considered to accumulate the utility value of the extension length with the utility value of all items on the extension itemset of the extension length. According to the upper bound property of utility value, the upper bound of relative utility value can be obtained. The specific expression formula is as follows:

$$G = \frac{\sum(\alpha, \alpha - 1) + \sum(\beta, \beta - 1)}{P}. \quad (1)$$

In formula (1),  $\alpha$  represents the quality value, and  $\beta$  represents the support. Based on formula (1), according to the given node sequence, the expression formula of the sum of utility values is as follows:

$$L = \frac{1 - (\alpha + \beta)^2}{|Q|} + H. \quad (2)$$

In formula (2),  $Q$  represents the number of itemsets,  $H$  represents candidate nodes, and  $\alpha$  and  $\beta$  have the same meaning as formula (1). When the sum of the overall utility values is less than the length of the newly added itemset, formula (2) becomes the following form:

$$E = \sum \frac{1}{|Q|^2} - \frac{\phi}{H}. \quad (3)$$

In formula (3),  $\phi$  represents the support of the root node and  $H$  and  $Q$  have the same meaning as formula (2). The sequential pattern can be regarded as a special association rule. Since it is used by teachers and students, it does not involve money or transaction, so there is no need to design too much security performance and simplify the complexity of the system. Data storage requirements are set according to the actual situation, mainly to meet the requirements of teachers and students in the actual application of data storage and reading. The main purpose of this section is to visually reflect the relationship between requirement entities in the system, describe user requirements, and establish connection channels through entity association. The management requirements of distance education system are

TABLE 4: Number of users of 500 connection speed (s).

| Number of experiments | Distance teaching system of Chinese language and literature based on leapfrog algorithm | Chinese language and literature distance teaching system based on genetic algorithm | Chinese language and literature distance teaching system in this paper |
|-----------------------|---|---|--|
| 1                     | 27.363  | 25.117  | 16.331   |
| 2                     | 26.595  | 24.166  | 17.255   |
| 3                     | 23.774  | 26.914  | 15.949   |
| 4                     | 26.119  | 23.003  | 16.323   |
| 5                     | 23.066  | 28.474  | 17.006   |

mainly for the convenience of data management. In the process of system design, login system is used to verify the user's account and password information [12, 13]. Only after passing the system verification can you enter the system and carry out relevant operations to make the data management more organized. Timely assignment of tasks to children with "optimal allocation" improves system scalability. Among them, the remaining processing capacity and free memory capacity of the processor are calculated by the computing process on the subnode receiving the subtask and then fed back to the task distributor on the CPU and written into the table of the CPU. According to the above conclusions, the optimal distribution degree of child nodes is calculated, and the calculation formula is as follows:

$$\gamma = \frac{\eta \times (1 - h)^2}{2}. \quad (4)$$

In formula (4),  $\eta$  represents the optimal allocation of the root node, and  $h$  represents the amount of free memory. Due to the different sizes of conditional mode bases and heterogeneous hardware of the children, the children with fast computing speed and many children with short conditional mode bases will have to wait. At this point, the correlation degree between data can be calculated as follows:

$$t = \frac{|\delta - \phi|}{(\eta)^2} \times W. \quad (5)$$

In formula (5),  $\eta$  has the same meaning as formula (4),  $\phi$  has the same meaning as formula (3),  $\delta$  represents the remaining processing capacity, and  $W$  represents the length of the conditional mode base. This approach is to be able to communicate with users more intuitively. Through analysis, we can know that students, teachers, courses, classes, and assignments are the main entities in the distance education system of Chinese language and literature [14, 15]. Through the analysis of system requirements, we know that the core functions of the system are more important: user management, course management, homework management, online examination function, and transform the logical structure

into the table structure in the database. According to the actual situation of the school, the system abandoned the application of large database in the design process, using XML technology, XML documents as storage medium, data directly stored in XML documents, and using PHP to read and write. PHP can read data text more quickly than large databases, with repeated reads and writes, recognition, and validation. In the process of database design in this paper, we first design the basic database table structure for each system submodule and then design the corresponding extended data table to achieve the relevant function expansion and finally consider the possible relationship between all kinds of database table structure and set up the corresponding primary key and search engine. So by giving up the system to the large database repeatedly call to improve the speed of data access, which is one of the highlights of the system design. Based on the above description, the steps of constructing the remote teaching system database are completed.

*3.3. Computer Multimedia Technology Design Software Recognition Function.* The basic meaning of computer multimedia in pedagogy refers to the combination of various multimedia educational media, so that the ways and channels of transmitting and presenting educational information are diversified rather than a single one [16–18]. Computer multimedia technology is to directly apply SMIL to courseware making in distance education system and provide teachers with a simple, convenient, and powerful synchronous multimedia courseware making tool by implementing a graphical SMIL making tool. This part mainly introduces the online classroom module and video q&a module to establish real-time communication control signaling. This multimedia combination is not simply addition or alternation, but organic combination according to the theory of teaching design, so that they complement each other, optimize the means and methods of transmitting and presenting information, so as to mobilize various teaching elements, mobilize students' multisensory participation in learning, and form an optimized teaching system structure. By establishing a shared teaching component library and providing a web-based synthesis tool, teachers can extract components from the component library to assemble their own courseware, thus realizing the sharing of teaching resources and the componentization of courseware making. At the same time, the system also provides students with a learning environment similar to TV 10 VCD teaching; students can not only choose the teaching content and can freely control the teaching content of fast forward, backward, volume, screen and size, giving students greater flexibility. The software part of the remote teaching system is a three-layer model of distributed application, and its presentation layer is the EXE solution based on teaching methods [19]. The reason why browser-based solution is not used is that its presentation layer is a complete SMIL document editing tool, which needs to deal with complex tasks and requires rich functions provided by the teaching platform of the underlying operation [20]. After making clear the quantitative index, we only need to find the test questions that meet these indexes and

compose the examination paper. Other indicators are positional indicators, which are effective during and after paper formation in online learning mode, such as test difficulty and question differentiation. In the remote teaching system of Chinese language and literature, the user's fuzzy test paper requirements are quantified into the test paper index requirements, and the specific expression formula is as follows:

$$Y = \lambda \sum \left( \frac{\mu}{2} \right)^2. \quad (6)$$

In formula (6),  $\lambda$  represents the completed test paper formation, and  $\mu$  represents all actions of test paper formation. In order to ensure the simplicity and standardization of the control signaling, this paper defines the control signaling of the system according to the JSON format that meets the requirements of online learning and establishes a bidirectional connection between the client and the signaling server through the secure WebSocket C WSS protocol to transfer the control signaling. In this case, the limited functionality provided by the browser is not sufficient. The paper forming index is rationalized, and the expression formula is as follows:

$$\sigma = m - r_{i=1} \left( \frac{r-1}{\sum m_i} \right). \quad (7)$$

In formula (7),  $m$  represents the differentiation of test paper topics,  $r$  represents the difficulty of test paper topics, and  $i$  represents the distribution of knowledge points. The expression formula of balance operation based on formula (6) and formula (7) is

$$T = \sum t \left( \frac{1}{g} \right)^{-1}. \quad (8)$$

In formula (8),  $t$  represents the verification times, and  $g$  represents the verification index of subject type conditions. Most of the major browsers (including mobile browsers) already have WebSocket built-in. Android and iOS have no built-in implementation, but third-party libraries can be used (for example, crossbar). IO autoBahn library can be used on Android. The iOS server can use the Facebook SocketRocket library to establish a WebSocket bidirectional connection. When the operating system starts up, the application server is automatically up and running as a service to the operating system. This allows the application server to be served immediately when the client application executes, reducing the server response time. Otherwise, COM/DCOM will activate the application server before serving the client if the application server is not already active when the client application executes. Through the WebSocket protocol, the client and signaling server can send and receive signaling simultaneously. The following uses the browser side as an example (implemented in JavaScript code) to show how the client can establish a connection with the signaling server, process the signaling returned by the signaling server, and

send signaling to the signaling server. If the application server takes a lot of time to activate, the first client to use the service will get a very slow response. The data layer of distance teaching system is realized by ADO accessing Microsoft SQL Server database. Taking a cue from the use of globally unique identifiers (GUIDs) by COM objects, assign the "ID" attribute in each component using the GUID value. The client first establishes a bidirectional WSS connection with the signaling server, and then when receiving the signaling message, the ONMessage event of the WSS object will be triggered. Then, the client parses the signaling message and selects an appropriate method to execute the signaling according to the signaling type and signaling name. For example, when receiving, after oomCreated responds to the signaling, the switch function will jump to the onRoomCreated method to perform subsequent operations. The GUID is a 128-bit random number. Theoretically, uniqueness is not absolutely guaranteed, but it is highly unlikely that identifiers will be identical. Its randomness is guaranteed by two characteristics: on the one hand, in space, for the computer in the network, usually take the MAC address of the network card, the computer without network card is generated by other random number generation algorithm. On the other hand, the identifiers generated by the same machine at different times are always different. When you click the send button on the IM page to send an IM, you need to determine the IM type. If the IM type is not plain text, you need to upload the image or file to the server and return the storage address of the image or file. The im module uses the producer-to-consumer pattern to process instant messages. Based on this, complete the steps of designing software recognition function.

#### 4. Simulation Test

Prepare test conditions according to test requirements. Use APACHE server software to build a web server; let students use IE browser as a web client. Unlike IIS in Windows Server and Windows XP Professional, Windows Server-based IIS 9.0 is installed in a highly secure and locked mode. The computer system used requires Windows 7 or above, using PHPSTUDY software to configure APACHE server, shorten the system configuration time. Use Dreaweaver CS6 software to beautify the front-end web page and enhance the rich sense of the page. By default, IIS only serves static HTML page content, which means Active Server Pages (ASP), ASP.net, indexing services, include files on the server side (SSI), Web Distributed Authoring and Versioning (WebDAV), and features such as the FrontPage Server Extensions will not work. LoadRunner 11 software is used to test the server and the client and debug the communication connection between the server and the client. In addition, both the teacher side and the student side use IE 10.0 browser as the interactive page. If these functions are required, they must be enabled manually. If you use an IIS application before these features are enabled, IIS will return a 404 error. Therefore, you should enable the required services after installing IIS 9.0. Linux server minimum configuration: 1 GB CPU P4, 1 GB memory, and 20 GB hard disk.

Recommended configuration: Core I5 2.8 GB, 2 GB memory, and 1206 hard disks or above. Quantity: 3 pcs. The remote teaching system of Chinese language and literature based on leapfrog algorithm and genetic algorithm is selected and compared with the remote teaching system of Chinese language and literature in this paper. Test the connection speed of the three systems under different user number conditions. Tables 1–4 shows the experimental results:

According to Table 1, the average connection speeds of the Chinese language and literature distance teaching system in this paper and the other two Chinese language and literature distance teaching systems are 2.051 s, 4.108 s, and 3.968 s, respectively.

According to Table 2, the average connection speeds of the Chinese language and literature distance teaching system in this paper and the other two Chinese language and literature distance teaching systems are, respectively, 3.219 s, 8.719 s, and 8.837 s.

According to Table 3, the average connection speeds of the Chinese language and literature distance teaching system in this paper and the other two Chinese language and literature distance teaching systems are 13.108 s, 14.350 s, and 14.286 s, respectively.

According to Table 4, the average connection speeds of the Chinese language and literature distance teaching system in this paper and the other two Chinese language and literature distance teaching systems are, respectively, 16.573 s, 25.383 s, and 25.535 s, proving that the Chinese language and literature distance teaching system in this paper has faster connection speeds under all three conditions.

## 5. Conclusion

In this paper, through research and analysis on the system module function design, to study the key technology of realization of each module and tests, build students and teachers as the main service object of the remote education system, inject new teaching model in the education field and innovation teaching mode to a large number of teaching resources to be shared, and promote education career of teaching to keep pace with the times. Affected by the research conditions, the paper also needs to further increase the security of system data storage under the condition of compatible speed and security.

## Data Availability

Data is available on request.

## Conflicts of Interest

The author declares that there are no conflicts of interest.

## References

- [1] D. Calhas, E. Romero, and H. Rui, "On the use of pairwise distance learning for brain signal classification with limited observations," *Artificial Intelligence in Medicine*, vol. 105, no. 1, article 101852, 2020.
- [2] C. Yansong, W. Fang, and C. Keliang, "Design of distance education system based on VR live broadcast," *Experimental Technology and Management*, vol. 37, no. 6, pp. 132–136, 2020.
- [3] C. Jomdecha, X. Li, W. Cai, S. Xie, and Z. Chen, "Advanced multi-media element for simulating distribution of magnetic flux density influenced by narrow crack," *IEEE Transactions on Magnetics*, vol. 55, no. 6, pp. 1–4, 2019.
- [4] C. Aliagas, M. Garcia-Famoso, R. Meseguer, P. Millan, and C. Molina, "A low-cost multicomputer for teaching environments," *Revista Iberoamericana de Tecnologías del Aprendizaje*, vol. 15, no. 3, pp. 171–182, 2020.
- [5] K. Ahmadjonova, "The use of multimedia technology in teaching foreign languages," *Scientific Bulletin of Namangan State University*, vol. 1, no. 1, pp. 37–47, 2019.
- [6] A. M. Sindiani, N. Obeidat, E. Alshdaifat et al., "Distance education during the COVID-19 outbreak: a cross-sectional study among medical students in North of Jordan," *Annals of Medicine and Surgery*, vol. 59, pp. 186–194, 2020.
- [7] M. E. Amer, "The impact of distance education on learning outcome in computer skills course in Prince Sattam Bin Abdulaziz University: an experimental study," *Journal of Curriculum and Teaching*, vol. 9, no. 4, pp. 1–9, 2020.
- [8] R. Wang, M. B. Alazzam, F. Alassery, A. Almulihi, and M. White, "Innovative research of trajectory prediction algorithm based on deep learning in car network collision detection and early warning system," *Mobile Information Systems*, vol. 2021, Article ID 3773688, 8 pages, 2021.
- [9] M. D. Abdulrahman, N. Faruk, A. A. Oloyede et al., "Multimedia tools in the teaching and learning processes: a systematic review," *Heliyon*, vol. 6, no. 11, article e05312, 2020.
- [10] R. Costa, G. Souza, T. Castro, R. Valentim, and A. Dias, "Identification of learning styles in distance education through the interaction of the student with a learning management system," *Revista Iberoamericana de Tecnologías del Aprendizaje*, vol. 15, no. 3, pp. 148–160, 2020.
- [11] V. Domenici, "A course of history of chemistry and chemical education completely delivered in distance education mode during epidemic covid-19," *Journal of Chemical Education*, vol. 97, no. 9, pp. 2905–2908, 2020.
- [12] M. B. Alazzam, F. Alassery, and A. Almulihi, "Development of a mobile application for interaction between patients and doctors in rural populations," *Mobile Information Systems*, vol. 2021, Article ID 5006151, 8 pages, 2021.
- [13] Ö. Eycan and S. Ulupinar, "Nurse instructors' perception towards distance education during the pandemic," *Nurse Education Today*, vol. 107, no. 2, article 105102, 2021.
- [14] L. Xiang, "Design of university distance education system based on ASP technology under background of the Internet," *Modern Electronics Technique*, vol. 43, no. 23, pp. 178–181, 2020.
- [15] Z. De-hong, "A study on the application of semantic network technology in a new distance education system," *Journal of Liaoning Institute of Science and Technology*, vol. 23, no. 1, pp. 17–19, 2021.
- [16] L. Xiao, "The design of distance teaching system based on Internet of Things," *China Computer & Communication*, vol. 33, no. 13, pp. 208–210, 2021.
- [17] T. Shiang, C. Cerniglia, H. Lin, and S. L. Hao, "Radiology podcasting as a model for asynchronous remote learning in the covid-19 era," *Clinical Imaging*, vol. 71, no. 10, pp. 147–154, 2020.



- [18] Z. Hui, "Simulation of multimedia video coding information sensory visual feedback enhancement," *Computer Simulation*, vol. 36, no. 2, pp. 113–116, 2019.
- [19] R. McInnes, "Developing multimedia collaboratively: practical approaches for large-scale online curriculum development," *Journal of University Teaching & Learning Practice*, vol. 16, no. 1, pp. 109–121, 2019.
- [20] R. Tsai, C. Đ. Nguyễn, Đ. S. Hồ, Y. H. Nguyễn, and R. H. Taylor, "Using mobile multimedia platforms in teaching dental diagnosis," *Journal of Taibah University Medical Sciences*, vol. 15, no. 4, pp. 265–271, 2020.

RETRACTED